

Identifying ViscoTwin Pumps, G7 & Earlier

ViscoTwin 70 (G7 & OLDER)

- 1) One Piece Lantern / Gear Housing
- 2) Eight Bolts on Gear Housing
- 3) Single NGI Foot under Bearing Housing
- 4) Seal Housing Enclosed
- 5) Pump Face Bolts are ~4.5" apart (center to center)

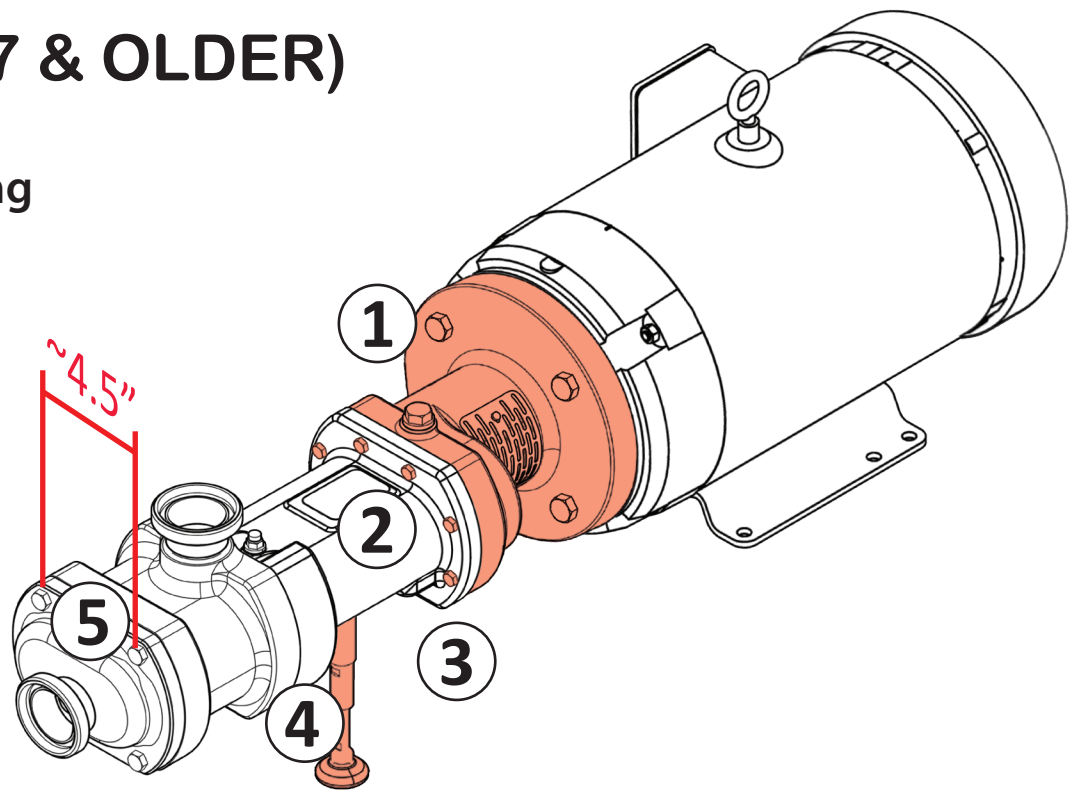

ViscoTwin 104 (G7 & OLDER)

- 1) Coupling Protection
- 2) Eight Bolts on Gear Housing
- 3) Cast Feet
- 4) Seal Housing is visible between Bearing and Pump Housing
- 5) Top Pump Face Bolts are ~6.75" apart (center to center)

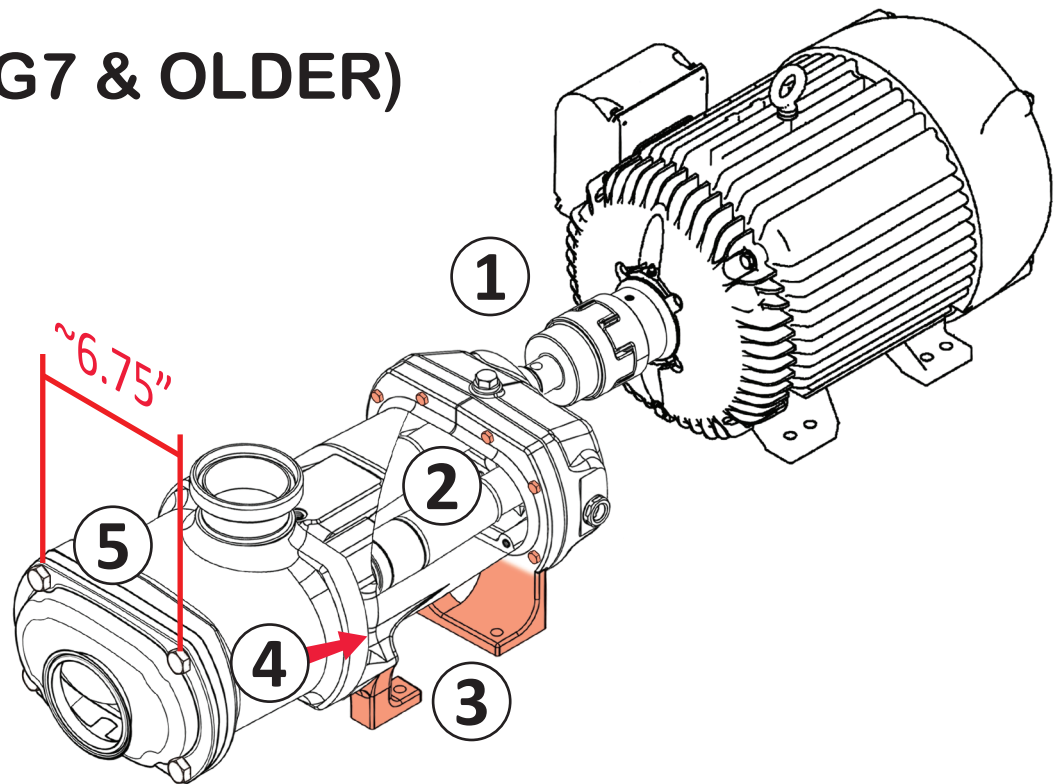

ViscoTwin 130 (G7 & OLDER)

- 1) Coupling Protection
- 2) Eight Bolts on Gear Housing
- 3) Cast Feet
- 4) Seal Housing is visible between Bearing and Pump Housing
- 5) Top Pump Face Bolts are ~7.25" apart (center to center)

