

PROCESSTEC

GET TOMORROW'S TECHNOLOGY TODAY

Manual

ViscoTwin

the most versatile sanitary pump

ViscoTwin 104 & 130 G7

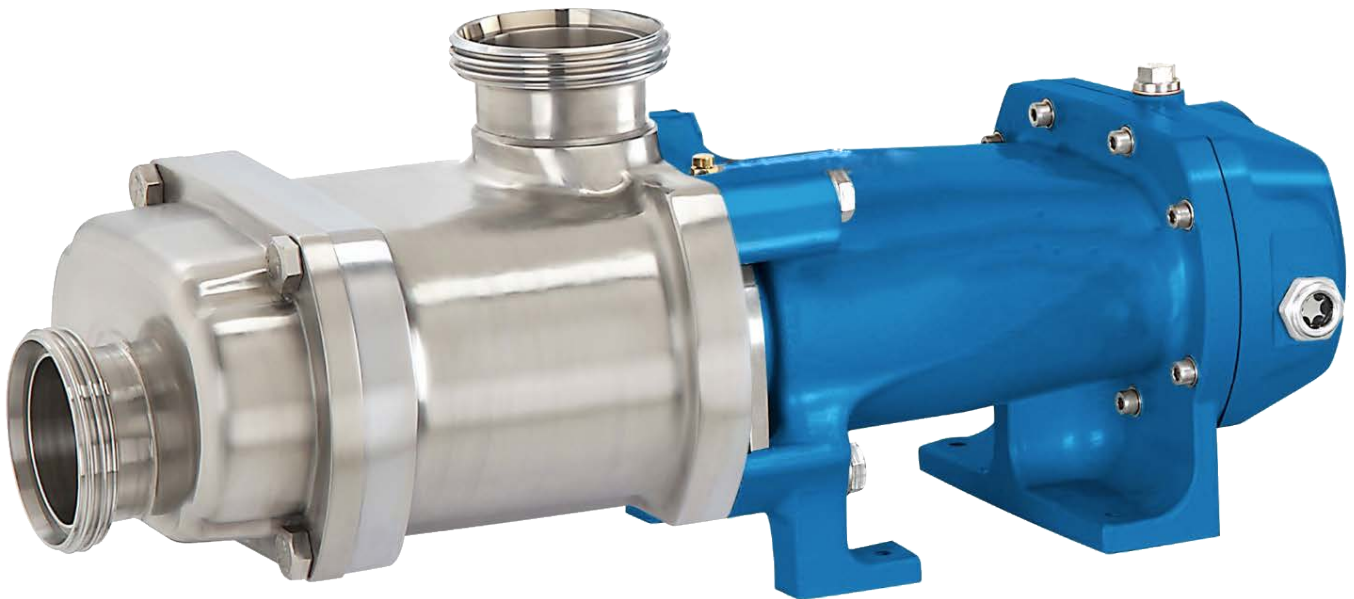

Processtec, Inc.

345 E Tulare Ave. Unit E. Visalia, CA 93277

Phone: +1(559) 429-4227 Fax: +1(559) 429-4228 | Email info@processtec.com | processtec.com

Table of Content

- 1 Safety notes
 - 2 Construction and general description
 - 3 Transport, packaging, storage
 - 4 Assembly / installation
 - 5 Commissioning
 - 6 Placing out of operation
 - 7 Maintenance and servicing
 - 8 Disturbances and their elimination
 - 9 Disassembly and assembly
 - 10 Stocking of spare parts
- Appendix
- Tools required for maintenance and servicing
 - Explosion drawings with index
 - The Engineering Design and Technical Construction File
 - CIP | SIP | Manual Cleaning
 - Oil change
 - Tightening torque values

All rights, also reproduction in the form of extracts thereof reserved.
All information is supplied without any liability.





Chapter 1

1. Safety notes

1.1 Important notes

- Read these instructions before assembly and initial operation.
- They describe the safe use of the pump in all life cycles.
- Heed the safety notes contained without fail
- Do not put damaged products into operation

The notes on safe and undisturbed operation are designated as follows:

Symbol	Signal word	Meaning	Consequences of disregard
Example.  General hazard  Specific hazard, e.g. electric shock	Danger	Imminent danger	Severe or fatal injury
	Warning!	Possible dangerous situation	Severe or fatal injury
	Caution!	Possible dangerous situation	Minor injuries
	Note!	Potential damage to property	Damage to pump or plant system
	Note!	Important notes on explosion prevention and protection	Neutralizing the explosion protection and resulting dangers
	Note!	For safe and undisturbed operation	

1.2 Qualified personnel

The operating company has to instruct the operator by means of this Operating Manual. The minimum age is 16 years. An experienced person has to supervise young persons and apprentices during the work on the machine.

Only metal workers, industrial mechanics or persons with comparable education may perform assembly, maintenance, initial commissioning, and repair work on the screw pump.

All electro technical work may only be performed by a trained electrically qualified person. Electrically qualified person in the sense of this Operating Manual are individuals who are familiar with electrical installation, commissioning, troubleshooting, and maintenance and hold a corresponding qualification for this function.

All work in the other fields, transport, storage, operation, and disposal may only be carried out by individuals who know the Operating Manual and have been appropriately instructed.

Make sure that the applicable standards and regulations of the respective country of use are kept and monitored.

Chapter 1

1.3 Further applicable documents

Heed the following additional documents:

Document	Description
Data sheet	Technical data, performance and operating limitations, service conditions
Dimensional drawing	Pump dimensions and connections with mounting points
Spare parts lists	Exploded drawing with spare parts
Assembly instructions	Special models or incomplete machine
ATEX supplementary instructions	Operating the pump in explosion hazardous area
Drive documentation	Drive Operating Manual
Accessories documentation	Accessories Operating Manual
Declaration of decontamination	Shipping the pump for repair

1.4 Safety Notes for Commissioning, Maintenance, Inspection and Installation works.

	Warning!!
	<p>The pump has live, pressurized, pressure-retaining and rotating or moved machine parts and possibly hot surfaces during operation. Potential consequences: Severe or fatal injuries.</p>

- Principally perform any necessary work on the machine when the system is at a standstill.
- Disconnect the electric drive from mains and secure against unauthorised and inadvertent activation.
- Make sure prior to opening the pump that the system and its auxiliary systems are in the no-pressure state.
- Keep in mind that the pump may possibly have hot surfaces during and after operation.
- Follow the regulations on handling the pumping medium when opening the pump.
- Reattach all protection devices before restarting.
- Heed the points stated in Chapter 'Commissioning' when restarting.

	Warning!
	<p>Risk of injuries through falling or tipping heavy machine parts. Potential consequences: Severe or fatal injuries.</p>

- The pump or parts of it may be very heavy and need to be moved using appropriate lifting gear.

Chapter 1

1.5 Intended Use

The machine is intended for commercial use and may only be employed for delivery of the agreed pumping media in accordance with this Operating Manual.

The operating points (delivery volume, pressure, rotational speed) mentioned in the pump specification (→ data sheet) should be understood as limit values and must not be exceeded.

Any change of the pump delivery conditions (e.g. delivery rate, delivery route, pressurisation level, pipe diameter, throttle devices) may result in strongly changed operating conditions. If this occurs, compare the new operating conditions with the data contained in the data sheet. You will need to consult with the manufacturer if the changed conditions should exceed the data contained in the data sheet.

Deployment in the Ex area is prohibited unless not expressly intended for this purpose.

1.6 Predictable Misuse

- Only use the pump to deliver the specified medium.
- Do not operate the pump beyond the specified speed range.
- The solids contents in the pumping medium must not exceed the specified limit values for grain size and proportion of solids.
- Take appropriate measures to ensure that no foreign objects (metal parts, stones, etc.) can get into the pump and possibly cause damage.
- Do not use the stationary pump as shut-off device.

1.7 Operating Restrictions

The screw pump is a positive displacement pump that can build up very high pressure. The developing pressure with the delivery line shut can reach the multiple of the permissible system pressure. This may result in serious damage to system components posing a risk to persons.

ATTENTION

Possible damage to property

- **Do not operate against closed shut-off devices!**
Breakage and risk of injuries!
- **Secure the pump through approved safety devices (overpressure protection).**
- Keep the relevant safety and handling instructions when delivering dangerous media.
- Medium contamination through foreign objects may result in damage to the pump elements.
- Observe the relevant legal requirements and the possibly resulting requirements and restrictions when delivering and storing hazardous substances and inflammable liquids.

Chapter 1

1.8 Specific safety notes

Provide constructional contact protection for hot and cold parts.
Provide appropriate earth in case of a possible electrostatic charge.

	Danger!
	Rotating screw spindles in the pump can draw in arms or other parts of the body. Imminent danger: Severe or fatal injuries.

- **Access into the pump during operation must not be possible.**
- **The running screw spindles can cause serious hand and personal injuries.**
- **Only operate the pump when mounted (connected to a piping system).**
- **Be sure to secure the openings (pressure and suction port) when running a possibly necessary test run.**
- **Only perform manual cleaning and maintenance work after disconnecting the drive (system control) from mains and protecting it from inadvertent and unauthorised reclosure.**

1.9 Specific safety notes on pumps with heating jacket

The housing of these pumps is of double jacket design and has connections for heating medium flow.

The housing has been designed for **6 bar** overpressure if no other internal pressure has been approved in the data sheet.

Use for the inlet- and outlet connection of the heating circuit the connectors on the opposite according to the nozzle. The connectors on the nozzle side can be used for the vent or a pressure measurement.

ATTENTION	Possible damage to property
------------------	------------------------------------

- **Operate the heating circuit exclusively using water.
Make sure by corresponding pressure limiting devices that the approved pressure rating for the housing will not be exceeded. The medium escaping via the relief port has to be discharged safely into a pressure less area when the pressure limiting device is responding. No shut-off devices are allowed to be arranged in this area.**

Manual ViscoTwin 130-xx

Chapter 2

2. Construction and general description

2.1 ViscoTwin pump construction



- only exemplary representation
Decisive for the dimension is the (dimensional drawing)
- 3-A baseframe according to 3-A requirements as per drawing #

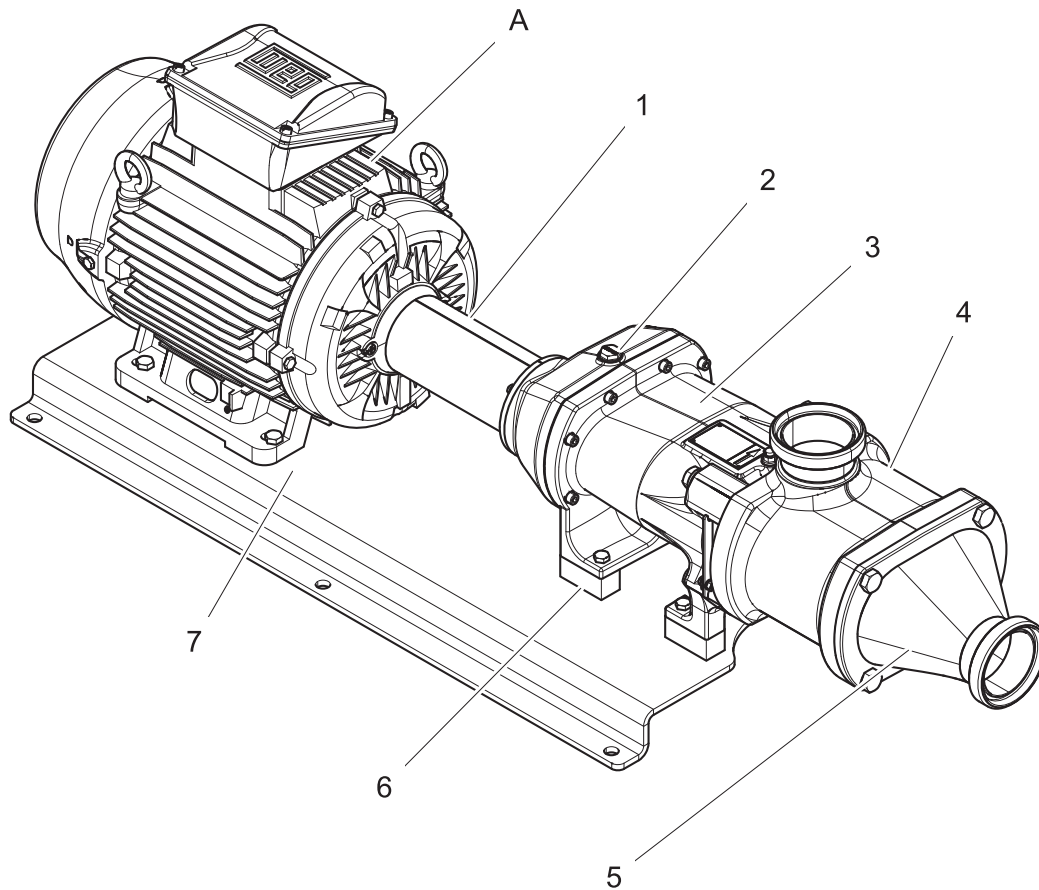

- A Drive
- 1 Coupling with guard
- 2 Gear housing
- 3 Bearing housing
- 4 Pump casing
- 5 Cover
- 6 Pump foot
- 7 Base plate

Chapter 2

2.2 General description

ViscoTwin Screw pumps are rotating displacement pumps for delivering low to highly viscose media.

Pumps for use in the foodstuffs and beverage industry are designed and built to the recommendations of DIN EN 1672-2 'Food processing machinery - Basic concepts'. This does not include pipe connections, which require special cleaning procedures. These must be cleaned manually by the operator. The cleaning cycle is dependent on the food and the relevant hazard from. This is set by the operator. Correspond to the pipe connections according to DIN 11864, according to DIN EN 1672-2 there is no health risk. The operator does not define any special cleaning measures.

Non-corroding materials suitable for cleaning and/or disinfection are being used for the product-contacting parts of these pumps. Elastomer materials and seals correspond to the BfR (German Federal Institute for Risk Assessment) recommendations and the FDA guidelines respectively (US Food and Drug Administration) and the Regulation (EC) No 1935/2004.

The pumps and pump units respectively are designed and built taking the health and safety requirements of the EC Machinery Directive into account with all requirements met, either the EC Declaration of Conformity (with CE mark) or in the case of partly completed machines, a Declaration of Incorporation is issued.

ViscoTec, Inc. is assuring the conformity of 3-A standard 02-11 for the pumps delivered to 3-A requiring purposes and verifies all parts and elastomer fulfill the sanitary standards also for spare parts.

2.3 Sound emission

Each pump is manufactured and tested acc. to the currently valid technical documentation. The weighted continuous sound level is normally <70 dB(A) with drive and pipe lines not included in this measurement. Cavitation-free operation and proper fastening of the pump unit on level concrete slab or warp resistant steel structure is taken for granted.

Manual ViscoTwin 130-xx

Chapter 3

3. Transport, packaging, storage

3.1 Transport / packaging

ViscoTwin pumps are shipped in non-returnable packaging. Any transport damage has to be immediately reported to the transport company after receipt of the consignment. Do not put damaged products into operation

	Warning!
	<p>The pump can drop or tilt as a result of improper transport. Potential consequences: Severe or fatal injuries.</p>

- Use only hoisting gear and load-carrying equipment with sufficient load capacity.
- Lift pumps with suitable load-carrying equipment (chains, ropes) properly acc. to opposing pictures using hoisting gear.

	<ul style="list-style-type: none"> • The pictures used are example pictures
---	--

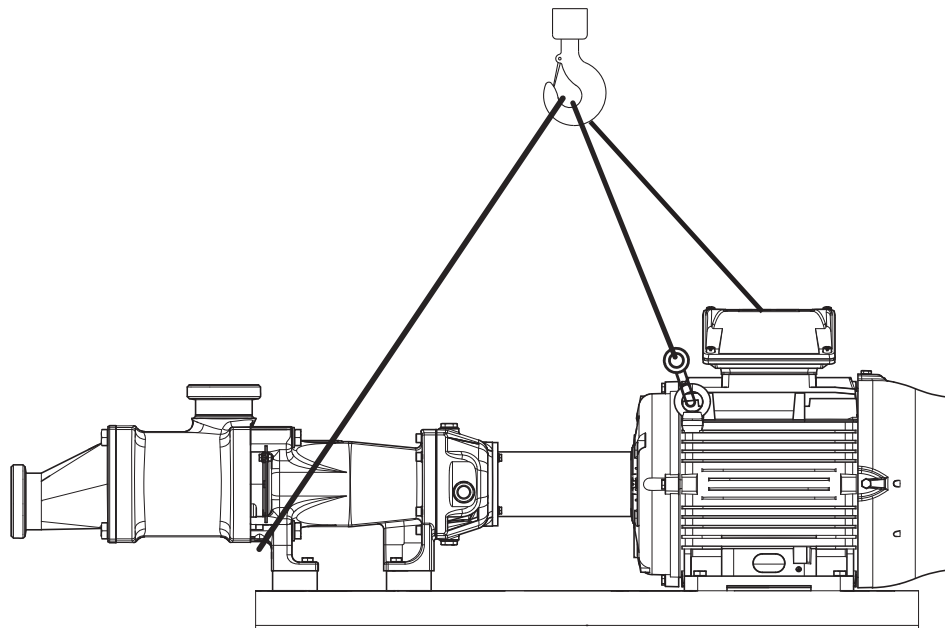

Fig. 3.1 ViscoTwin 130 with baseplate and drive

ATTENTION	<p>Possible damage to property</p>
------------------	---

- When transporting pump units, consider that they can be very top heavy due to certain drive assemblies.
- Never lift the whole unit using the lifting eye bolts of the drive unit. These suspension points should only be used for the motor and/or gear unit.
- Always transport screw pumps in horizontal position.

Chapter 3

3.2 Storage

ViscoTwin pumps are sufficiently preserved under normal environmental conditions. Take the following measures when storing for a longer period;

- **Protect pump from dust, dirt, water, and other harmful environmental influences. Coat all non-painted surfaces with acid-free and resin-free grease.**
 - **Do not grease stainless steel parts and non-metallic parts.**
 - **Cover all openings of pressure and suction ports.**
 - **Drain water when using it as quench medium for shaft seal.**
1. Make sure that the storage room meets the following conditions:
 - frost-protected and dry.
 2. Check the preservation regularly.

3.3 Disposal

Collect oil from gear unit and seals and dispose of acc. to the local regulations

3.3.1 Final decomposition of the pump, sorting

Check parts for applicability as spare parts and optionally store it.

Dispose of casing parts, screw spindles, shaft seals as steel scrap (VA scrap).

O-rings and parts of the rotating mechanical seals made from carbon/ceramics as residual waste.

Manual ViscoTwin 130-xx

Chapter 4

4. Assembly / installation

4.1 Rotational direction

The rotational direction of the drive shaft determines the direction of flow. The rotational direction is stated on the data sheet and on the pump casing / coupling guard.

4.2 Speed and torque of the pump

The permissible speed and the maximum torque on the clutch shaft of the screw pumps are shown in the following table:

Type of pump	Min. Rotation	Max.	Maximum torque on the clutch shaft
ViscoTwin 130	100 rpm	2900 rpm	400 Nm

4.3 Mounting

Mounting of the pump in the case of the screw pump is done via the holes in the base plate and the holes in the case foot respectively.

Provide for a solid and level ground, such as:

- **A sufficiently dimensioned, level concrete slab,**
- **a level and warp resistant steel structure.**

The foundation has to sustain the dead weight and all operating forces and guarantee pump unit stability.

The size of the holes on the casing or base plate predetermine the diameters of the screws or dowel anchors.



- **Normally, mounting is done by screwed connection (hexagon head screws, dowel anchors). In this context, observe the following screw diameters and max. torqueing values:**

Screw diameter	Max. tightening torque
M10	44 Nm
M12	90 Nm
M16	220 Nm

(The values apply for hexagon head bolts to DIN 931-B or EN 24014 of strength category 8.8)

The pump units need to be tightly mounted to the base plate mounting points when the pump unit is put up on 4 – 6 calottes. With this job done, the pump unit needs to be horizontally aligned by adjusting the calotte feet so that the pump stands safely and firmly on the ground.

For the base frame installation of pumps meeting the requirements of 3-A Sanitary Standards (Standard 02-11) leveling feet also meeting the requirements of 3-A Sanitary Standards (Standard 88-00) have to be used.

For pumps meeting the requirements of 3-A Sanitary Standards (Standard 02-11) a clearance of at least 100 mm between aggregate console and the floor has to be observed.

Mobile pump units have to be locked via their fixing wheels prior to commissioning.

Chapter 4

4.3.1 Tightening torques for specified components

Tightening torques has been specified for certain components as shown in appendix.

4.4 Pipe lines

Correct dimensioning of the pressure-side pipe line is crucial to avoid unnecessary pressure build up when delivering viscous media. Therefore, orient yourself at least by the dimensions of the pump flanges. The pressure stated in the data sheet must not be exceeded. Mind the delivery pressure stated in the data sheet with respect to the pipe line pressure resistivity. Purge the piping system and the feeding devices and clean them from foreign objects.

Seal pipe connections for quench exclusively with a sealing tape. Do not use liquid seals. Liquid seal can clog the inner flushing lines.

ATTENTION

Possible damage to property

- **Do not use liquid seals.**
- **Liquid seal can clog the inner flushing lines.**

4.4.1 Connection of the pipe lines

1. Clean and purge the pipes.
2. Flange the pump to the pipe line via elastic seals so that a tight connection develops and no undue forces act on the pumps.
3. Provide shut-off devices for removing the pump and maintenance and fitting pieces in the pressure and suction lines.
4. Provide safety valve or pressure monitoring right into the pipe line behind the pump.

Chapter 4

ATTENTION	Possible damage to property
------------------	------------------------------------

- Do not support pipe lines on the pump! Mount pipe lines as force- and torque-free as possible.
- Allow for the permissible forces and torques on the ports (see table below) when connecting the pipe lines.
- Do not stress threaded connections with torques causing pipe clamping or declamping in the pump casing.

4.4.2 Permissible forces and torques on the pump flanges

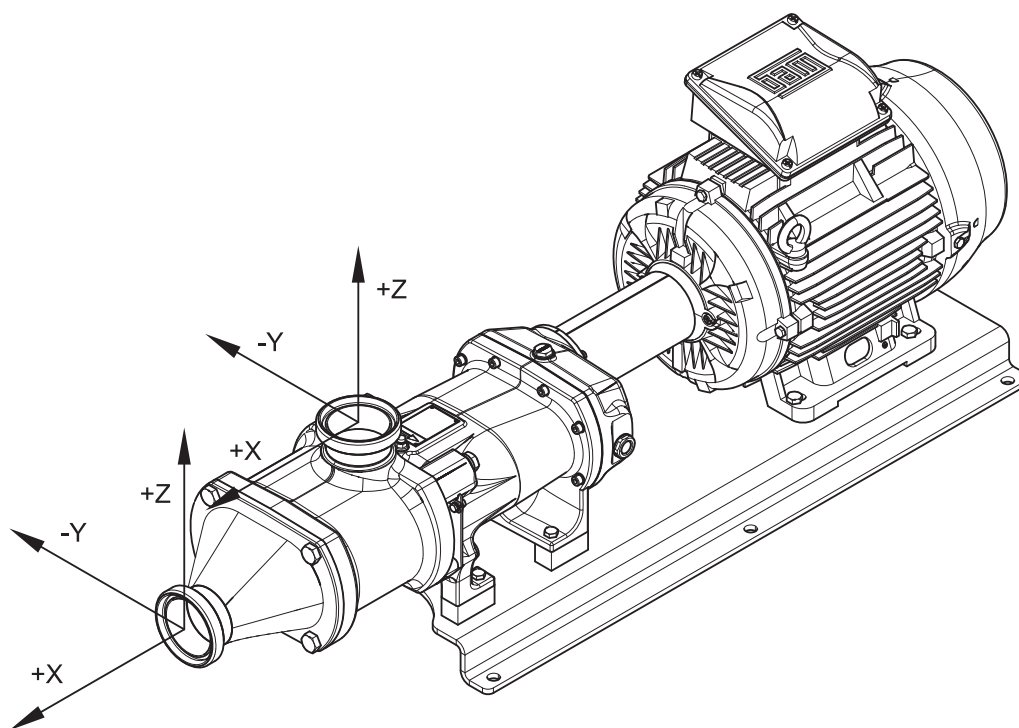

$$F_{ges} = \sqrt{F_x^2 + F_y^2 + F_z^2} \quad \text{and} \quad M_{ges} = \sqrt{M_x^2 + M_y^2 + M_z^2}$$

Nominal width	F (x,y,z) [N]	F (tot) [N]	M (x,y,z) [Nm]	M (tot) [Nm]
65	700	1000	310	450
100	840	1200	380	550
150	1190	1700	560	800
200	1540	2200	730	1050

4.5 Permissible pressure in the pump casing

The permissible internal compressive stress is specified in the datasheet.

Manual ViscoTwin 130-xx

Chapter 4

4.6 Operation and maintenance space requirements



- Allow for free space around the pump (→ dimensional drawing to provide for maintenance work without removing the pump. To simplify installation, use fitting pieces and shut-off devices.
- In addition, plan free space for sufficient drive motor ventilation (→ drive documentation).

4.7 Electric connection



Danger!

Danger to life through electric shock!
Potential consequences: Severe or fatal injuries.

- **Electrical connection by qualified personnel only.**
- **Disconnect system from mains and prevent unintentional restart/reclosing.**
- Check the data on the motor type plate against mains voltage and frequency before connecting the motor.
- When connecting the motor, it is an imperative to heed the drive manufacturer's instructions and the applicable regulations for electrical equipment (e.g. motor protection, main switch).
- Check the phase sequence for the direction of motor rotation prior to making the connection.
- Screw pumps are preferably operated on frequency converters or on soft-start control units.

Three-phase current squirrel-cage motor

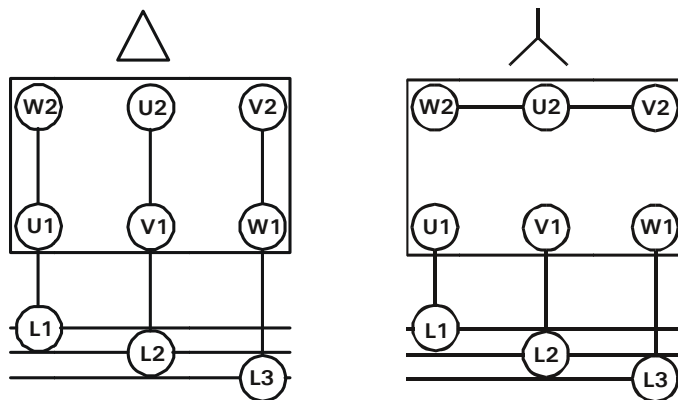

Low

high

voltage stated on the type plate.

- Provide emergency stop facilities to shut down the pump in the event of dangerous situations.

Manual ViscoTwin 130-xx

Chapter 4

4.8 Driving elements

	Warning!
	<p>Driving elements are quickly moving during operation. They can squash hands. Potential consequences: Severe or fatal injuries.</p>

- Always cover driving elements with a protective guard.

4.8.1 Coupling elements

ViscoTwin screw pump with free shaft (cylinder shaft with shaft key) are connected to the drive through a flexible coupling.

<div style="border: 2px solid black; padding: 2px; display: inline-block;">ATTENTION</div>	<p>Possible damage to property</p>
---	---

- Do not mount using a hammer
- Use a pull-on device or heat the coupling half to approx. 90 °C. (Remove rubber parts before) and mount the coupling in hot condition.

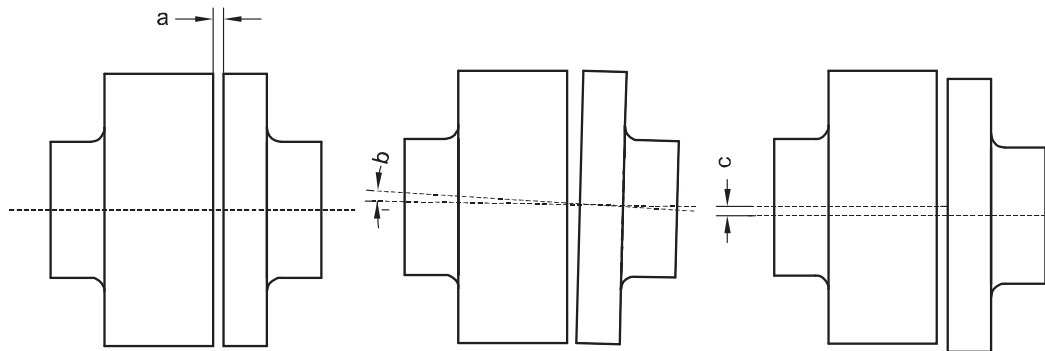

	<ul style="list-style-type: none"> • The coupling halves must be aligned against each other.
---	---

- When assembling the drive with the pump, it is necessary to adjust
 - a = Maximum and minimum clearance
 - b = Angular offset and
 - c = Axial offset
 acc. to the coupling manufacturer's specifications. (Enclosures)

4.9 Mounting and adjusting additional equipment accessories

Mount additional equipment accessories (speed measuring devices, counter-pressure systems) according to the attached instructions (see Appendix).

Manual ViscoTwin 130-xx

Chapter 4

4.10 Shaft seals

It is of the essence that there is a lubricating and cooling film between the seal faces. Depending on application, there are various methods of ensuring that the appropriate medium is being fed to the seal so that this film can be developed. Different types of rotating mechanical seals can be installed into the screw pump. The built-in version is stated on the data sheet.

4.10.1 Single acting mechanical seal

The seal is being lubricated through the medium.

4.10.2 Single acting mechanical seal with Quench

In this version rotary shaft lip type seals provide a quench chamber at the mechanical seal. The quench fluid is being supplied to the seal via a quench reservoir, and the quench fluid is circulated back into the reservoir via a return pipe.

4.10.3 Double-acting mechanical seal with quench and thermo siphon rotation

In this version, the quench fluid is being supplied to the seal via a quench reservoir, and the quench fluid is circulated back into the reservoir via a return pipe.

The quench medium circulates between seal and quench vessel due to the elevated temperature on the rotating mechanical seal faces during pump operation.

Make sure before starting the pump that the quench medium can circulate from the seal to the vessel and back. Carefully bleed the system.

For this purpose, attach the quench vessel approx. 1-2 m above the pump and the seal and vessel should be connected through tubes preferably made from stainless steel. Other tubes or even hoses can also be used temperature and medium permitting. The lines towards the seal inlet must be fastened in continuously falling way and the lines from the seal outlet back to the vessel must be fastened in a continuously rising way. (See Fig. 4a)

ATTENTION

Possible damage to property

- **The quench medium should not exceed a temperature of 70 °C.**
- **No bubbles should form since otherwise circulation would no longer be ensured.**
- **In case that quench fluid temperature has to be cooled, the vessel can be equipped with a condensing coil through which cold water flows.**

4.10.4 Double-acting mechanical seal with flow

The seal is flown through by a quench medium in this version. This medium is supplied from an external source (pressure pipe system, pump, connected 'water line', etc.).

Please ensure that the quench supply has been connected to the seal and quench fluid is flowing through the seal before the pump is started. This is necessary to ensure that the sliding surfaces on the outside are being cooled. Carefully bleed the system.

Both pressure and flow through the seal can be adjusted using a flow meter and two control valves. This flow should be adapted to the heat generation on the seal depending on pressure, speed and media temperature.

Adjust the flow such that the quench fluid outlet temperature does not exceed 40-45°C. The flow velocity should not drop below 1 l/min.

Manual ViscoTwin 130-xx

Chapter 4

4.10 Quench media

The manufacturer uses only quench fluids suitable for food products (e.g. distilled water). Some usable quench media are being shown below. Change these quench media at regular intervals. Do not use aggressive quench fluids.

Glycerine/water mix

This mixture is used in different concentrations. Glycerine does not boil until 290 °C and decomposes in the process. The water vaporises in continuous operation and has to be regularly refilled particularly at higher temperatures of up to 150 °C. Suitable for foodstuffs.

Glycol/water mix

This is also used in various concentrations. Glycol does not boil until 190 °C. The water vaporises in continuous operation and has to be regularly refilled particularly at higher temperatures of up to 150 °C. Suitable for foodstuffs.

Distilled water

Distilled water is a poor lubricant but cools very well. The water boils at 90-100 °C. The water vaporises in continuous operation and has to be regularly refilled particularly at higher temperatures of up to 80 °C. Suitable for foodstuffs.

The following rules have to be kept when using water as a quench fluid:

Solid particles max. 10 mg/l

Particle size max. 50 µm

Permanganate value max. 30 (humus-free)

Iron content max. 1 mg/l

Water hardness max. 10 ° of German hardness (dH)

Critical particle size 2-5 µm

Do not use any de-ionized water

Critical particles of the above-mentioned size of 2 – 5 µm can accumulate between the sliding surfaces resulting in increased wear.

4.11 Quench connections

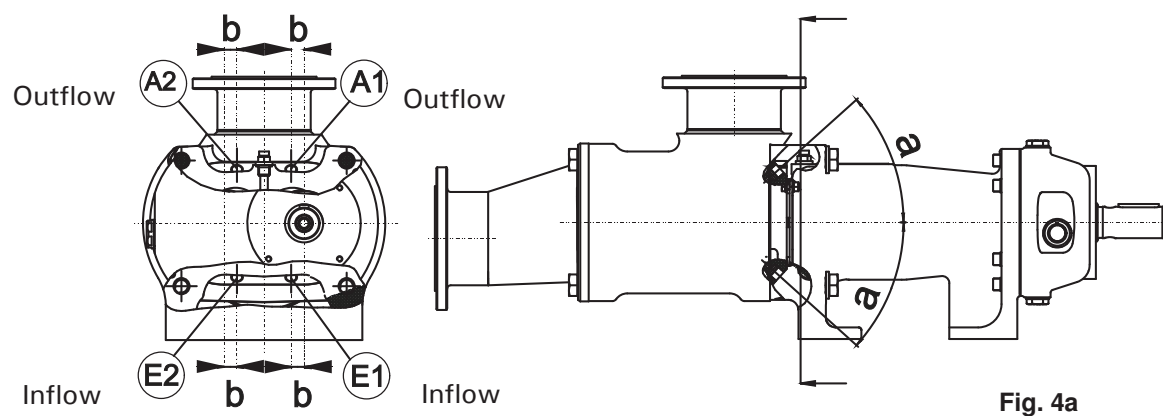

Pump type	a	b	A1	A2	E1	E2
104	37°	12,5 mm	G1/4"	G1/4"	G1/4"	G1/4"
130	42°	14,4 mm	G1/4"	G1/4"	G1/4"	G1/4"

Manual ViscoTwin 130-xx

Chapter 5

5. Commissioning

5.1 Preparing commissioning

	Warning!
	Risk of injuries through rotating machine parts or from liquids escaping under high pressure. Potential consequences: Severe or fatal injuries.

- **Do not perform any work with the pump running!**
- **Only let qualified personnel perform commissioning.**

5.1.1 Pump

Clean the pump prior to initial commissioning.

5.1.2 Sealing system

1. Check the shaft seal (version → data sheet).
2. Oil level in the pump gearbox checked?
3. Auxiliary systems (quench supply of the seals) connected?

ATTENTION	Possible damage to property
------------------	------------------------------------

- **Pressurise double-acting mechanical seals using the counter-pressure system.**
- **Operation without quench medium can destroy the seal.**

5.1.3 Pumps for handling foodstuffs

Deploying ViscoTwin pumps for handling foodstuffs make sure that they are clean before commissioning and each production cycle. Cleaning can be carried out as follows:

- **Basically by disassembling the pump and manual cleaning of the component parts using the detergents required for that purpose (hand cleaning).**
- **By the so-called C.I.P. - Cleaning (Cleaning in Place) or S.I.P. (Sterilisation in Place), flushing using appropriate cleaning agents, provided the cleaning method is permissible for this medium.**

A clean in place treatment on the pump should be executed at the following times:

- **When the pump is first commissioned for use**
- **When any spare components are fitted into the wetted area of the Pumpenfabrik Wangen**
- **After operations, i.e. before a fairly long idleness of the pump**
- **After long idleness, before re-operation**

With the CIP cleaning process completed, subsequent to initial commissioning, first cleaning cycles, corresponding periods, and any modifications on the system, cleaning process or detergent, the cleaning efficiency has to be inspected (i.e. whether the pump is really clean) by disassembling the pump.

The operator is responsible for securing the cleaning success. The manufacturer cannot assume any warranty for the cleaning success and does not accept any liability for consequential damage.

Chapter 5

5.1.4 Pumps in a processing system by 3A Standard (02-11)

Pumps to be used in a processing system not designed so that the system automatically is shut down if the product pressure in the system becomes less than of the atmosphere and cannot be started until the system is resterilized shall have a steam or other sterilizing medium chamber surrounding (1) the shaft, (2) the portion of the inlet and outlet connection adjacent to the product, and (3) the pump cover.

C.I.P. – process

Are suitable for the materials of the pump:

Surfactant-containing solutions (usually NaOH and HNO₃) with temperatures between 60 and 95 °C and concentrations of 0.5% up to 3%.

Acidic solutions with a pH value of less than 3 must not be used.

S.I.P – process

Are suitable for the materials of the pump:

Sterilization at 125 - 135 °C over a period of 10 to 30 minutes with saturated steam (2.2 – 3.0 bare).

	Warning!
	Risk of injuries through rotating machine parts or from liquids escaping under pressure. Potential consequences: Severe or fatal injuries.

- **Do not perform any work with the pump running!**
 - **Disconnect the pump from mains and secure against inadvertent start up. (U-lock)**
 - **Use safety gloves and goggles when using aggressive detergents.**
1. Connect pump to CIP cleaning system or switch system.
 2. Start cleaning system.
 3. Cleaning pipe line system and pump.
 4. Shut cleaning system, remove CIP medium completely.

	• C.I.P. cleaning must conform to the hygiene of foodstuffs regulations as amended from time to time. The specifics pertaining to material stability must be strictly observed.
	• In case you have developed own C.I.P. cleaning methods for your pumping media, ensure pump suitability for the selected method by consulting the pump supplier.

ATTENTION	Possible damage to property
------------------	------------------------------------

- **Avoid abrupt changes in temperature during the cleaning process. With the pump in stationary state, fill in hot medium and wait until the pump has warmed up.**

Chapter 5

5.2 Switching on

Check before switching on:

- **Pump with drive safely installed and connected?**
 - **Connections sealing and connected stress-free?**
 - **Oil level checked?**
 - **Quench fluid level OK? Correct pressure set in case of a counter-pressure device?**
 - **Rotational direction checked?**
 - **Safety devices (covers and limit switches, safety valve) installed and checked for function?**
1. Before start up, check pump for contamination and foreign objects.
 2. Fully open pressure and suction-side valves.
 3. Fill pump with medium to enable suction safely.
 4. Switch on drive.
 5. When initially operating the pump, check to see whether it and the pipe lines are tight.

5.3 Operation

	Warning!
	Do not operate against closed shut-off devices. Bursting of the pipe line or downstream system components is possible. Potential consequences: Severe or fatal injuries.

- **Secure the pump through an approved overpressure protection.**

ATTENTION	Possible damage to property
------------------	------------------------------------

- **The pump needs to be cleaned for handling foodstuffs (→ Commissioning pumps for handling foodstuffs)**

Chapter 6

6. Placing out of operation

	Warning!
	Rotating machine parts or liquids escaping under high pressure. Potential consequences: Severe or fatal injuries.

6.1 Shutting off

1. Stop the pump by shutting down and switching off the drive unit.
2. Shut the pressure and suction-side valves.

	Caution!
	Risk of injuries through hot machine parts Potential consequences: Burns.

6.2 Drainage

Drain the pump after shutdown and clean it, particularly when:

- **it is a pump for foodstuffs,**
- **the pump was deployed outdoors and the medium can freeze up due to atmospheric influences,**
- **the pumping medium tends to settle / cool or hardens through chemical reaction.**

6.3 Decommissioning

Please observe following measures when decommissioning the unit or shutting it down for a longer period:

- **Clean the pump thoroughly.**
- **Open the cover so that residual water can run out.**

6.4 Final decommissioning of the pump

1. Disconnect the electrical power (electrical engineering professionals).
2. Close the inlet and outlet lines. Remove pipelines. Drain the pump. (Professionals)
3. Complete emptying and cleaning of the pump. (Professional and material disposal of the residues see also chapter 3)

Chapter 7

7. Maintenance and servicing

	Warning!
	<p>Risk of injuries through rotating machine parts Potential consequences: Severe or fatal injuries.</p>

7.1 Maintenance after commissioning

All external screw connections of the pump or pump unit should be checked and, if necessary, tightened after approx. 50 hours of operation.

7.2 Notes on service and maintenance

Period	Assembly	Who	Jobs
weekly	Gear housing	Operator Technical staff	→ Check oil level → If necessary, top up/change oil, Chapter 7
	Slip-ring seal	Operator Technical staff	→ Check for leakage → In case of stronger leakage Coordinate with manufacturer. Replace slip rings or sealing rings Chapter 9
	Shaft sealing rings	Operator Technical staff	→ Check for leakage → In case of stronger leakage Coordinate with manufacturer. Replace shaft sealing rings Chapter 9
	Counter-pressure system Quench system	Operator Technical staff	→ Check for leakage → Refill counter-pressure/quench medium if necessary. → Check slip-ring seal and replace counter-pressure/quench medium if quench medium is contaminated.
After the first 250 operating hours	Gear housing	Technical staff	→ Check tightening moment of the spindle nut Chapter 4
monthly	Pump housing	Technical staff	
6 months	Counter-pressure system Quench system	Technical staff	→ Change counter-pressure/quench medium
After 500 cleaning cycles or after one year	Pump casing and mechanical seal	Technical staff	→ Renew all o - rings Chapter 9
According to the specifications of the drive manual	Drive	Technical staff	→ Grease bearings (Drive manual)
In continuous operation after 3000operating hours	Gear housing	Technical staff	→ Change gear oil Chapter 7

Chapter 7

7.3 Lubrication

Pump bearings and gear run in an oil bath. Replacement of these bearings and gear wheels is recommended after 20,000 hours of operation.

You should set shorter change intervals for particularly difficult operating conditions, such as:

- large temperature variations
- large pressure fluctuations

In the interest of a long pump life-cycle.

The gear has been factory provided with food-compatible high-performance gear oil. The table below represents the necessary quantity of lubricant.

Change this gear oil after 3,000 operating hours or after 1 year latest.

Grease the drive bearings following the manufacturer's specifications (→ drive documentation).

7.3.1 Checking the oil level

Check the oil level in the gear housing weekly. Top up the gear oil if necessary.

7.3.2 Topping up the gear oil

1. Switch –off pump.
2. Open locking screw 2233 on the upper side of the gear housing.
3. Clean the locking screw thoroughly.
4. Fill in gear oil until reaching maximum in the oil-level gauge glass.
5. Screw in the locking screw.

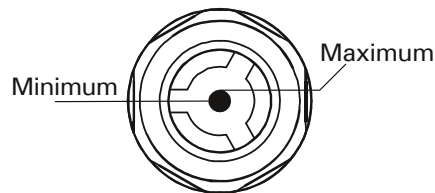

Fig. 7.1 Oil-level gauge

7.3.3 Changing the gear oil

1. Switch -off pump.
2. Open locking screw 2233 on top of the gear housing. The open lower locking screw 2233 and drain the gear oil into a collecting vessel.
3. Clean the locking screws thoroughly.
4. Screw in lower locking screw and fill in fresh gear oil.
5. Fill up to the oil-level gauge glass (maximum).
6. Screw in the upper locking screw.

ATTENTION

Possible damage to property

- **Only use gear oil approved for the food industry.**
- **Use correct type of gear oil. (See list of lubricants)**

Chapter 7

7.4 Lubricating agents

7.4.1 Gear oil with NSF or USDA H1 approval

The following gear oil suitable for food products to the FDA guideline NSF-H1 and viscosity of ISO VG 220 is factory-used in the screw pump for applications in the food sector.

Product	Gear oil
Castrol	Optileb Hy 68

Other gear oils of other producers and makes that correspond to the same qualification can be alternatively used. (e.g.)

Product	Gear oil
AVIA	AVIAFOOD GEAR 220
Mobil	Mobil DTE FM 220

7.5 Lubricating grease

A lubricant to NSF-H1 that is approved for the food industry is used at the factory during the installation of the pump components. Use this or equivalent lubricant during assembly.

Product	Lubricant
Fuchs Lubritech	Geralyn [®] 2

7.6 Lubricants filling quantities

Table 1: Quantity of lubricant for installation sizes

Pump series	Quantity of lubricant (litres)
ViscoTwin 104	0.8
ViscoTwin 130	1

ATTENTION

Possible damage to property

- **Do not mix together synthetic lubricants and do not mix with mineral lubricants.**

Chapter 7

7.7 Maintenance of shaft seal

Check the quench fluid filling level regularly and at least once a week. Top up the quench fluid as required or change the fluid at regular intervals. The filling level can also be monitored using a level indicator.

Persisting leakage (medium seeps out from the lower opening in the bearing housing) indicates wear of the slip rings or damage to the elastomer rings.

Mechanical seals being operated under counter-pressure need also to be checked for this counter-pressure or monitored via corresponding monitoring equipment (level switches).

7.8 Disassembling the pump

	Warning!
	Risk of injuries through rotating machine parts or from liquids escaping under pressure. Potential consequences: Severe or fatal injuries.

- **Do not perform any work with the pump running!**
 - **Disconnect system from mains and prevent unintentional restart/reclosing.**
 - **Only qualified personnel may carry out work on the electric system.**
 - **Only let qualified personnel carry out pump disassembly.**
1. Shut down the pump.
 2. Shut the suction and pressure-side valves.
 3. Let the pump cool.
 4. Drain the pump; collect the flowing out pumping medium and dispose of it.
 5. Disconnect the pump from electrical energy.
 6. Remove connections of auxiliary systems (sealing systems, temperature sensors, etc.).
 7. Remove the pump from the system.

7.9 Shipping the pump for repair

	<ul style="list-style-type: none">• Repair work is only carried out with the declaration of decontamination at hand.
---	---

1. Drain and clean the pump.
2. Seal all openings and holes.
3. Ship the pump to the manufacturer along with completely filled in declaration of decontamination
4. Attach information about reasons of repair and operating conditions.

Chapter 8

8. Disturbances and their elimination

Disturbances on pumps and pump units can basically be of hydrodynamic, mechanical or electrical nature.

8.1 Mechanical and hydrodynamic disturbances checklist

Type of disturbance	possible cause	Elimination
Pump does not start	Jam by foreign objects	Remove foreign objects
	Deposits at shutdown	Immediately clean pump
	Medium hardens (due to temperature/chemical action)	
	Solids content too high	Check pump delivery conditions, change project planning if necessary
	System pressure too high	Compare pump pressure rating with system conditions, change project planning if necessary
Delivery rate decreases or is not reached any longer	Shut-off devices partly shut, pipe line clogged	Open shut-off devices fully, eliminate clogging
	Screw spindles worn	replace
	Trapped air in medium	Check suction line, medium supply and seals
	Seals defective	Replace seals
Pump does not suck	wrong direction of rotation	Correct direction of rotation, observe directional arrow
	Spindles mounted incorrectly	mount spindles correctly
	Suction line clogged	clean
	Pump or filter clogged	Clean pump / filter
	Suction line draws air.	Seal line / Increase filling level when sucking from tank
Loud pump noise	Cavitation, rotational speed too high or suction pipe too narrow, clogged	Check project planning, chose lower speed if necessary, increase pipe line cross-section

8.2 Electric disturbances

Disturbances in the electric drive of the pumps or the pump unit can have numerous causes (power supply, dimensioning of the drive, motor protection, etc.).

Eliminate disturbances in connection with the electric drive following the attached drive manufacturer's operating and maintenance manual.

Chapter 9

9. Disassembly and assembly

	Warning!
	Risk of injuries through rotating machine parts or from liquids escaping under pressure or hot surfaces. Potential consequences: Severe or fatal injuries.

- Do not perform any work with the pump running!
- Don not operate pump without lantern protection!
- Disconnect system from mains and prevent unintentional restart/reclosing.
- Drain the pump and connected pipe lines and check the surface temperature before opening.
- Let the pump cool.

	Warning!
	Risk of injuries through falling or tipping heavy machine parts. Potential consequences: Severe or fatal injuries.

The pump or parts of it may be very heavy and need to be moved using appropriate lifting gear.

9.1 General notes on disassembly and assembly

	<ul style="list-style-type: none">• Always replace the removed gaskets, O-rings and shaft sealing rings after disassembly.• The numbers stated in the following figures are the F-numbers of the spare parts list.
---	---

Please see the enclosed exploded drawing incl. spare parts list for the designations used for the parts.

9.2 Lantern protection

The lantern protection behind the seal housing reliably prevents reaching into the pump. It can be removed for better accessibility of the pump parts for maintenance and repair work.

The pump must not be operated without a mounted lantern protection.

Chapter 9

9.3 Disassembling and installing the pump

9.3.1 Driving elements

	Caution!
	<p>Risk of jamming and crushing when disassembling the drive. Potential consequences: Minor injuries</p>

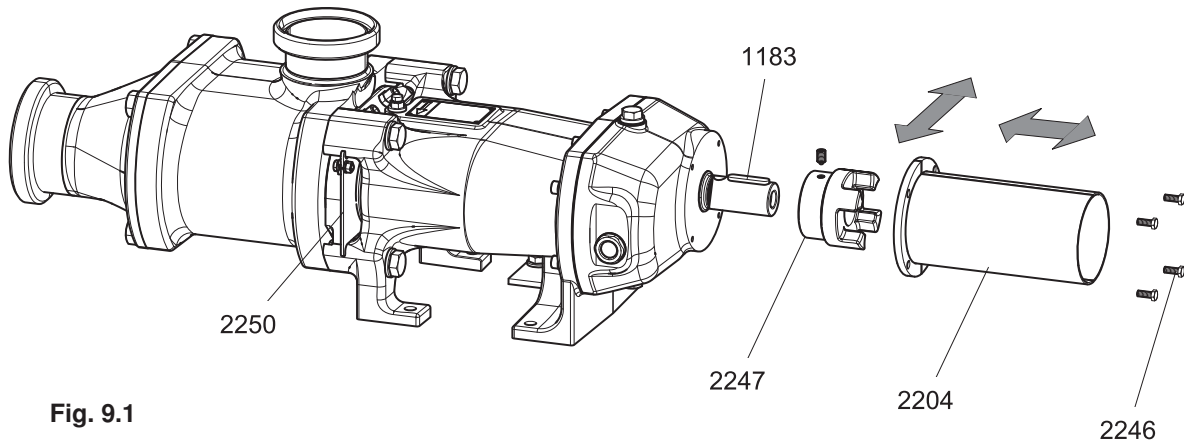

Fig. 9.1

Disassembly:

1. Loosen screws 2246 using a socket of size 10 mm and remove screws and coupling guard.
2. Disconnect the pump from piping system. Loosen the fastening of the pump on the base plate, carefully lift the pump and remove it from the coupling. (Lifting gear) Remove flexible coupling element and keep it.
3. Loosen the threaded pin in coupling part 2247 and pull it out from the pump shaft using a suitable puller. Lift key 1183.

Installation:

4. Insert key into the drive shaft. Slightly grease the drive shaft and slide the coupling onto the shaft. Screw in the threaded pin and tighten it.
5. Mount pump, align it toward the drive. (see chapter 5)
6. Insert both halves of the coupling guard, insert screws 2246 and tighten them.

ATTENTION	<p>Possible damage to property</p> <ul style="list-style-type: none"> • Do not mount the coupling using a hammer. • Use a pull-on device or heat the coupling to approx. 90 °C (remove rubber parts before) and mount the coupling in hot condition.
------------------	---

Chapter 9

9.3.2 Gear housing

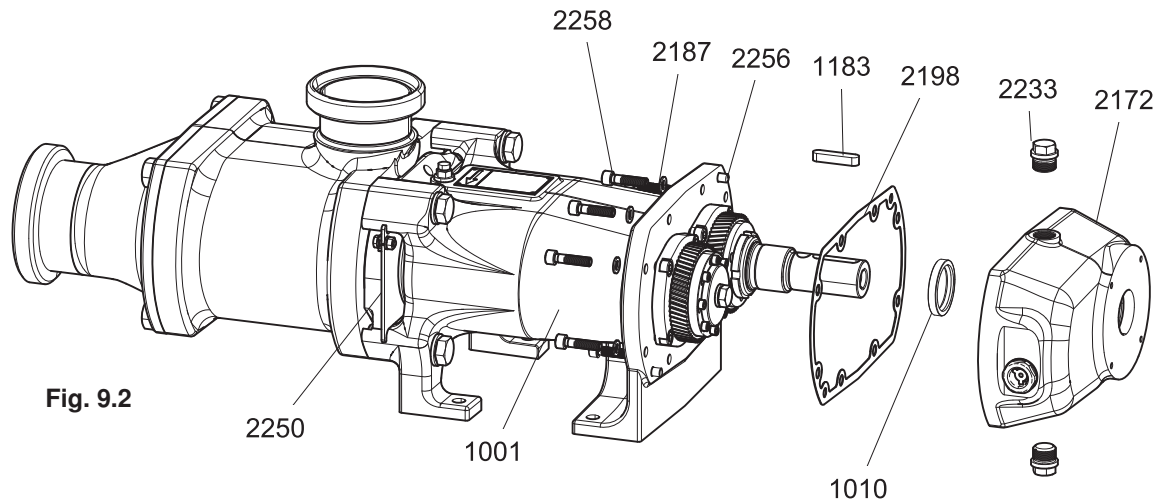

Fig. 9.2

Disassembly:

1. Remove key 1183.
2. Open the upper locking screw 2233 and then the lower locking screw 2233 in gear housing 2172 and drain the gear oil into a sump tray.
3. Loosen the screws 2258 and remove them together with the washers 2187. Carefully pull off the gear housing. This may require slight hammer blows (plastic hammer) since the gear housing has been fitted with cylindrical pins 2256. Carefully remove gasket 2198.

Installation:

4. Clean the sealing surfaces between bearing housing 1001 and gear housing 2172.
5. Insert new gasket 2198.
6. Insert gear housing 2172 into the cylindrical pins 2256, insert and tighten the cylinder head screws 2258 including washers 2187. (Torque 20 Nm)
7. Screw in and tighten the lower locking screw 2233, fill in clean gear oil (see chapter 'Maintenance') and check the oil level on sight glass 1541.
8. Screw in and tighten upper locking screw 2233.

Chapter 9

9.3.3 Cover

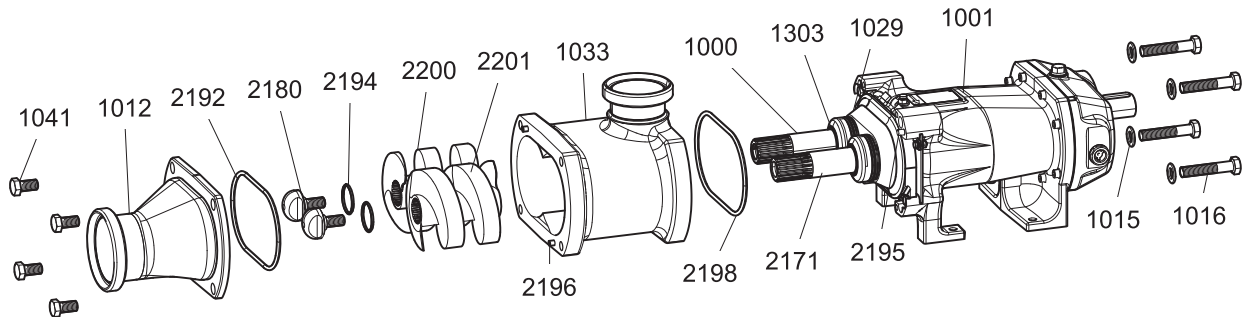

Fig. 9.3

Disassembly

1. Loosen and remove screws 1041.
2. Remove the cover.
3. Thoroughly clean the cover and its seal seat.



- If necessary, loosen the cover using slight blows of a hammer (plastic hammer) because it is centred by dowel pins 2196.

Installation:

1. Insert seal 2192 into the cover. Place the cover onto pump casing 1033 via the cylindrical pins, screw in and tighten screws 1041.

9.3.4 Removing and installing screw spindles



- Relieve existing counter-pressure device, drain quench fluid, unscrew and remove connections.

Disassembly:

1. Loosen and unscrew hexagonal screws 1016 and remove them with washers 1015. Remove pump housing.
2. Loosen and unscrew spindle screws 2180 while holding drive shaft 1000 tight via locking hole using a tool (steel mandrel), carefully remove O-rings 2104.
3. Remove screw spindles 2200 + 2201 from the shaft. (Use puller)
4. Check the screw spindles, shafts as well as the pump casing for damage and carefully clean all parts. Replace O-ring 2198 on seal housing 1029.

Chapter 9

Installation:

Installation:

1. Carefully slide the screw spindles (imperative in pairs) onto the shafts. The left-hand spindle will then be located on the driver shaft (long shaft) and the right-hand spindle on the driven shaft. Observe correct seat of the O-rings when sliding the spindle onto the seal.
2. Insert O-ring 2194 into the greased groove of the spindle nuts.
3. Screw in spindle nuts on both shafts and slightly tighten alternating, manually at first, then using an open-end spanner. In this process, just hold shafts and spindles in place manually.



- **The seals are prestressed when slightly tightening the spindle nuts. Check to see that exterior stator 1A is slowly pushed into the seal housing against its spring.**

4. Tighten the spindle nut on the driving shaft (long shaft) while holding the shaft in place in the drive shaft with the steel mandrel inserted in the hole. Torque = 150 Nm.
5. Tighten driven shaft spindle nut using torque of 150 Nm and block the shaft by inserting a wedge made from soft material (aluminium or copper).
6. Let pump housing 1033 slide into the dowel pins via the screw spindles, insert and tighten screws 1016 with washers 1015 via the bearing housing.
7. Further pump assembly in reverse order.

ATTENTION

Possible damage to property

- **Carefully slide the screw spindles together onto the shafts.**
- **Before screwing in the spindle screws, wet both threads on the spindle screws with a thread-locking compound (factory uses Loctite 270).**
- **Observe the required tightening torques (Chapter 4)**
- **When replacing screw spindles, you will also need to synchronize them via the pinion gear drives (see Chapter 9.6)**

Chapter 9

9.3.5 Arranging the pump casing

There are 3 intended arrangements of the dowel pins corresponding to the three different positions of the pump casing. The arrangement of the different positions is shown in colours here.

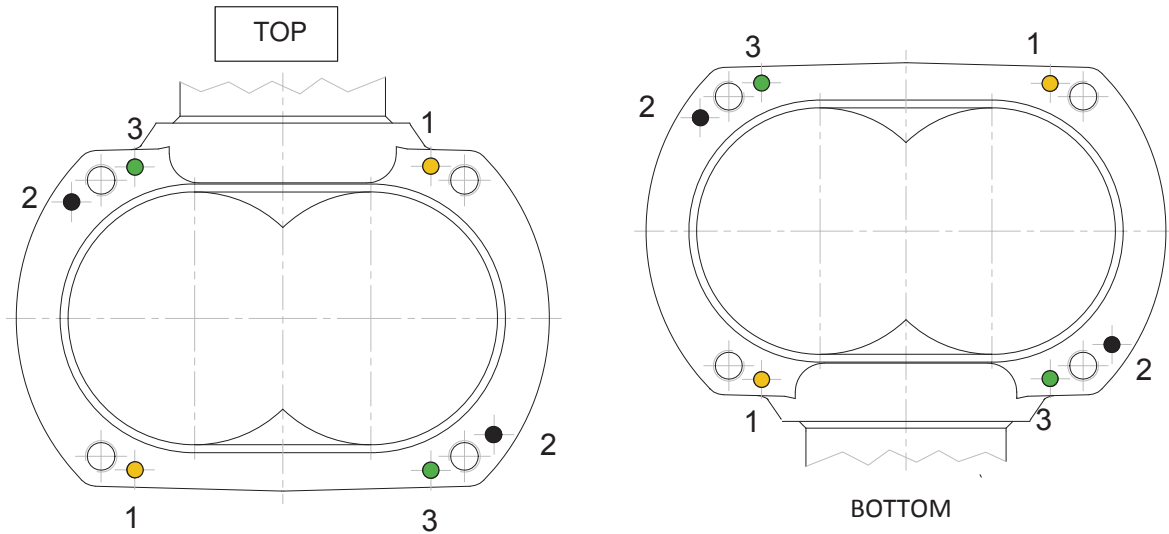

		Pos. of housing nozzle	
		TOP	BOTTOM
Rotating direction	LEFT	1	3
	LEFT/RIGHT	2	2
	RIGHT	3	1

ATTENTION

Possible damage to property

- Wrong combination of the dowel pin arrangement and wrong direction of load rotation results in damage to the pump casing and spindles.
- See the data sheet for correct arrangement of the dowel pins (direction of rotation, direction of flow and position of the housing nozzle).

Chapter 9



- The pump casing must be clean.
- Screw spindles must also be meticulously clean.
- Apply lubricant to shafts and hubs of the screw spindles (factory uses Geralyn® 2).

9.3.6 Arranging the spindles

Right-hand and left-hand spindles can be swapped but this will change the flow direction of the pump as well as reversal of drive rotation direction.

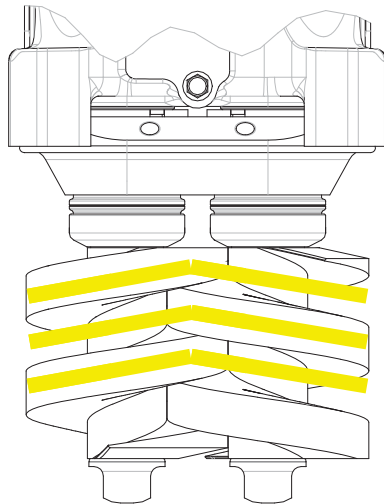

V

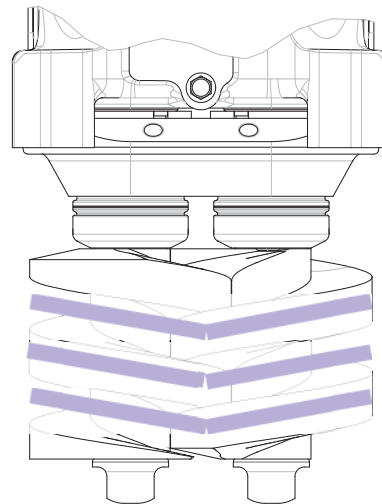

A

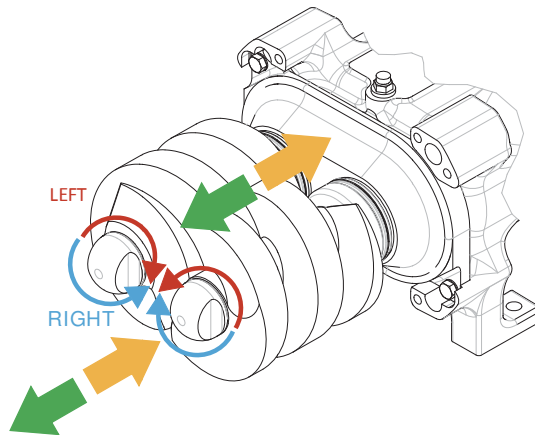

		Flowdirection	
		V	A
Rotation-direction	LEFT		
	RIGHT		

For example: The medium will flow toward the cover nozzle in 'Forward' flow direction and left-hand drive rotation

Chapter 9

9.4 Shaft seal

9.4.1 Shaft seal (single-acting)

Disassembly:

1. Disassemble cover 1012.
2. Disassemble pump housing 1033.
3. Disassemble both screw spindles.
4. Pull down inboard rotor holders 80 from the shaft. Inserted in it are seal face 40, drive pins 210 as well as O-rings 90, 130 and 220. Twist the inboard rotor holder quickly while pulling to separate the seal faces.
5. Loosen screws 2259 of seal housing 1029 and remove it from the shafts along with the remaining seals.
6. Remove the inboard stators 11 from the seal housing. Remove O-rings 140 located in the front section of the seal housing.
7. Using circlip pliers, grasp and remove the retaining rings 200 on the rear of the seal housing. In addition, remove spacers 190, backup rings 180 as well as wave rings 50 in backward direction.
8. Finally, remove drive disc 150 along with drive pins 210 from the seal housing.

ATTENTION

Possible damage to property

- Equally clean the seal housing as well as the shafts and seal seats and carefully check the removed parts. Replace any damaged parts as well as all O-rings and shaft sealing rings
- During disassembly be careful about the drive pins 210. If they get lost use new ones. Therefore use grease to stick them in the holes of the drive discs 150 and inboard rotor holders 80 respectively.

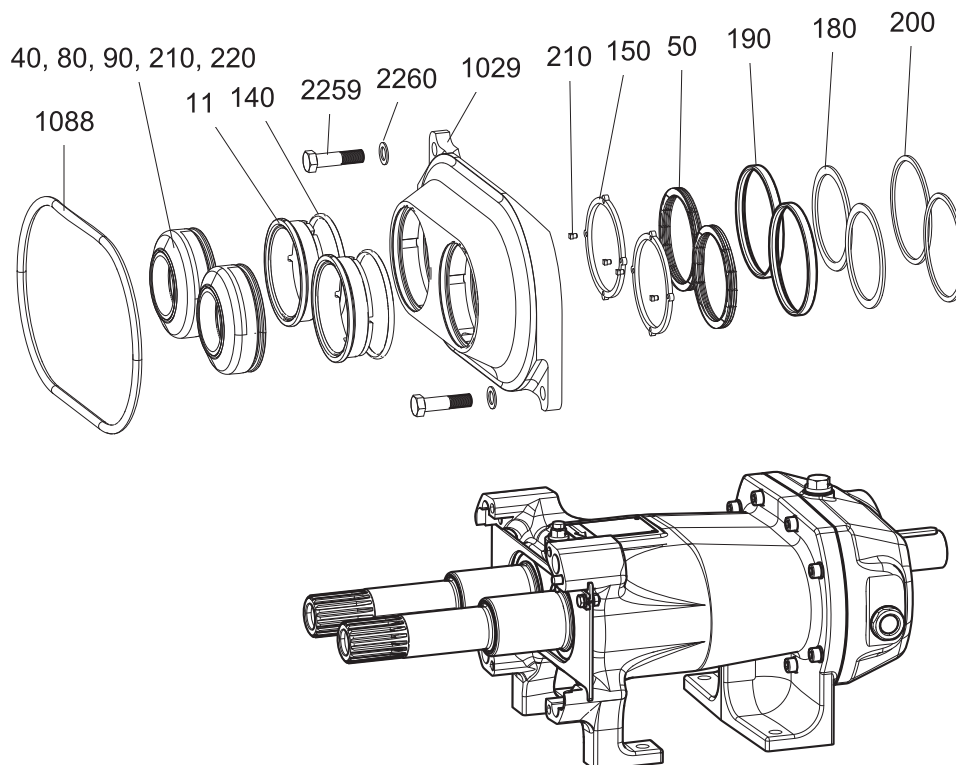
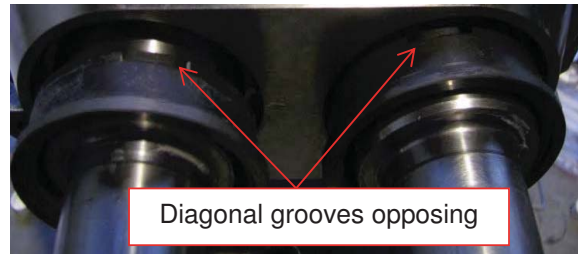

Fig. 9.5a

Chapter 9

Installation:

1. Insert drive disks 150 with the pre-assembled drive pins 210 (glue them into the disc ring using grease) into the seal housing from behind. The drive pins must be directed to the front
2. Fit backup rings 180 into the rear groove of the seal housing. Push wave ring 50 against it from behind. Slide spacers 190 against it.
3. Insert retaining rings 200 using circlip pliers.
4. Insert O-rings 140 into the front groove of the seal housing.
5. Carefully slide the seal housing onto the shafts. Position screws 2259 with washers 2260 and screw them into the pump casing. Tighten the fitting screws (10 Nm torque).
6. Carefully slide inboard stators 11 into the seal housing via the shaft. The stator groove must engage with drive pins 210 of drive disc 150. (see picture)
7. Place inboard rotors 80 incl. seal faces 40 and built-in O-rings onto the shaft.



ATTENTION

Possible damage to property

- Check the free room of motion of the sealing by pushing the inboard rotor holder and spinning it bidirectional. During spinning a small gap shall be noticeable, coming from the gap between the drive pins 210 and the grooves they are positioned in the seal faces. During pushing the gap between the stator 11 and the seal housing 1029 shall stay circular constant.

- Therefore dimension A in the drawing showing the sealing cross section shall be controlled. (depth gauge)

$$A = 33.3 \pm 0.3 \text{ mm (ViscoTwin 130); } 25.2 \pm 0.3 \text{ mm}$$

8. (ViscoTwin 130)

When installing the screw spindles make sure that the O-rings 130 (are located to the front of the inboard rotor holders) are correctly placed in their receptacle. The seals will now be prestressed during the installation of the screw spindles.

9. Insert O-ring 1088 in seal housing, insert pump housing 1033.
10. Screw in screws 1016 with washers 1015 and tighten. (torque 150Nm)
11. Set cover in place with O-ring 2192, screw in screws 1041 and tighten them. (torque 150Nm)

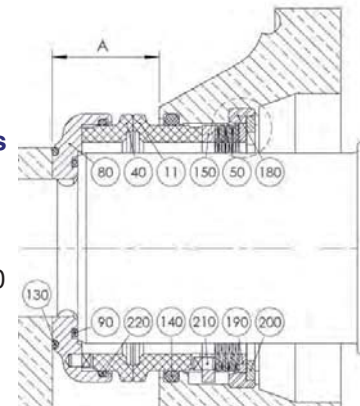

ATTENTION

Possible damage to property

- Slide the screw spindles together onto the shafts.
- Before screwing in the spindle screws, wet both spindle screws 2180 at the spindle nuts with a thread-locking compound (factory uses Loctite 270).
- Observe the required tightening torques (Chapter 4)
- When replacing screw spindles, you will also need to synchronize them via the pinion gear drives (see Chapter 9.6)
- Keep the sliding surfaces free from dust and grease. Avoid any contact with the hands. If necessary, clean with a soft, clean cloth and acetone.

Chapter 9

9.4.2 Shaft seal (single-acting with quench)

Disassembly:

1. Drain the quench fluid. Disassemble the auxiliary systems.
2. Disassemble cover 1012.
3. Disassemble pump housing 1033.
4. Disassemble both screw spindles.
5. Pull down inboard rotor holders 80 from the shaft. Inserted in it are seal face 40, drive pins 210 as well as O-ring 90, 130 and 220.
6. Loosen screws 2259 of seal housing 1029 and remove it from the shafts along with the remaining seals.
7. Remove the inboard stators 11 from the seal housing. Remove O-rings 140 located in the front section of the seal housing.
8. Press out the shaft seals 2272 from seal housing.
9. Using circlip pliers grasp and remove the retaining rings 200 on the rear of the seal housing. In addition, remove spacers 190, backup rings 180 as well as wave rings 50 in backward direction.
10. Remove drive disc 150 along with drive pins 210 from the seal housing.
11. Loosen sets screws 1064 in shaft sleeves and pull off of from shafts. Remove Centrifugal disk 2275. Renew shaft seal 2272 and the centrifugal disk 2274.

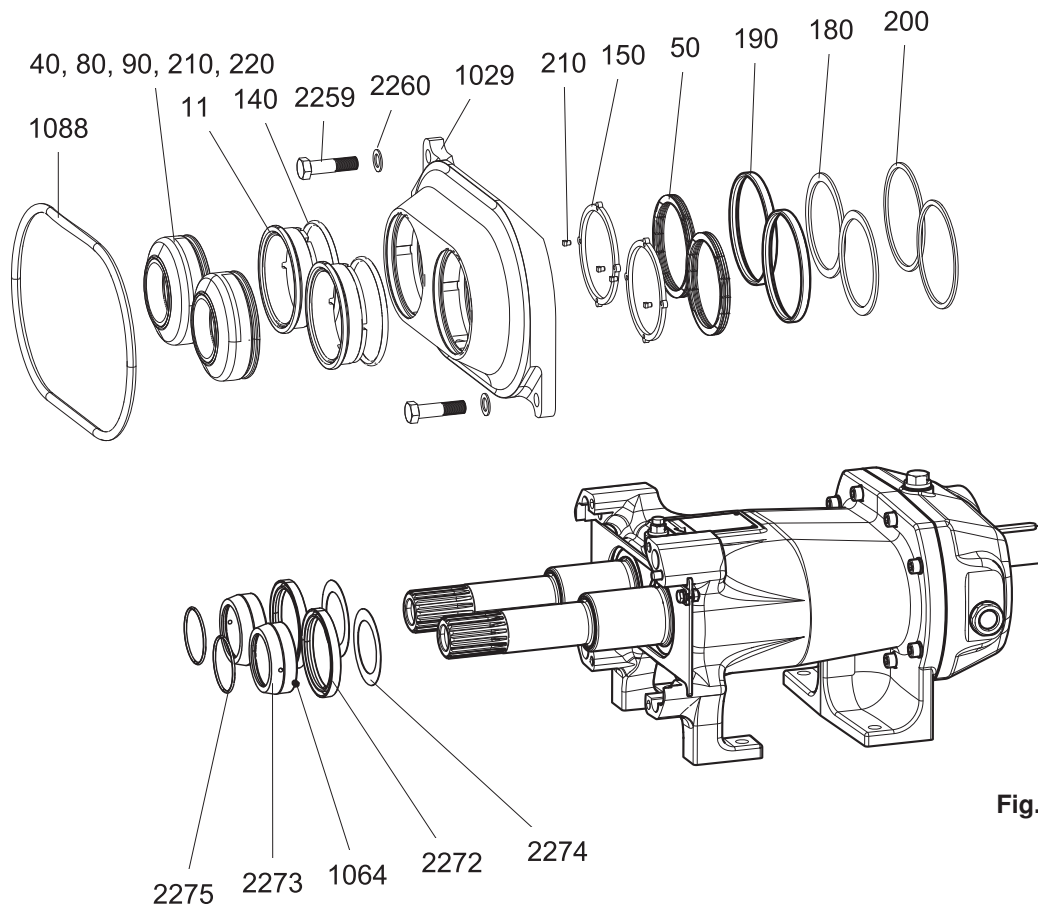

Fig. 9.5a

Chapter 9

ATTENTION

Possible damage to property

- Equally clean the seal housing as well as the shafts and seal seats and carefully check the removed parts. Replace any damaged parts as well as all O-rings and shaft sealing rings
- During disassembly be careful about the drive pins 210. If they get lost use new ones. Therefore use grease to stick them in the holes of the drive discs 150 and inboard rotor holders 80 respectively.

Installation:

1. Insert disc rings 150 with the pre-assembled drive pins 210 (glue them into the disc ring using grease) into the seal housing from behind. The drive pins must be directed to the front.
2. Fit backup rings 180 into the rear groove of the seal housing. Push wave ring 50 against it from behind.
3. Slide spacers 190 against it.
4. Insert retaining rings 200 using circlip pliers.
5. Insert O-rings 140 into the front groove of the seal housing.
6. Insert centrifugal disk 2274 onto both shafts (against the shaft, shoulder its must be tight)
7. Insert O-rings into shaft sleeves 2273. Lightly grease the shaft sleeves 2273 and push against the centrifugal disk 2274. Screw in set screws 1064 into the shaft sleeves while keeping pushed towards the centrifugal disk and fix it. (1.5 Nm torque)
8. Press in shaft seals 2272 into seal housing 1029.
9. Carefully slide the seal housing onto the shafts. Position screws 2259 with washers 2260 and screw them into the pump casing. Tighten the fitting screws (10 Nm torque).
10. Carefully slide inboard stators 11 into the seal housing via the shaft. The stator groove must engage with drive pins 210 of drive disc 150. (see picture)
11. Place inboard rotor holders 80 incl. seal faces 40 and built-in O-rings onto the shaft.

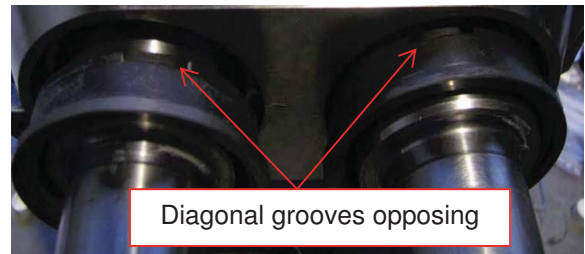

ATTENTION

Possible damage to property

- Check the free room of motion of the sealing by pushing the inboard rotor holder and spinning it bidirectional. During spinning a small gap shall be noticeable, coming from the gap between the drive pins 210 and the grooves they are positioned in the seal faces. During pushing the gap between the stator 11 and the seal housing 1029 shall stay circular constant.
- Therefore dimension A in the drawing showing the sealing cross section shall be controlled. (depth gauge)

$$A = 33.3 \pm 0.3 \text{ mm (ViscoTwin 130)}$$

12. When installing the screw spindles make sure that the O-rings 130 (located to the front of the inboard rotor holders) are correctly placed in their receptacle. The seals will now be prestressed during the installation of the screw spindles. (see 9.3.4)
13. Insert O-ring 1088 in seal housing, insert pump housing 1033.
14. Screw in screws 1016 with washers 1015 and tighten them. (torque 150Nm)

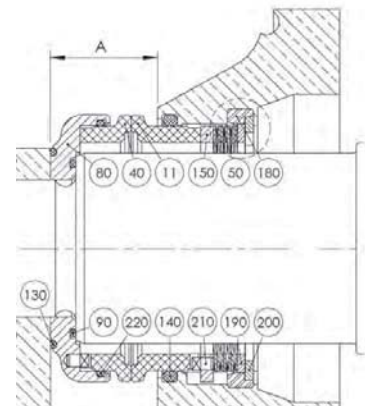

Chapter 9

15. Set cover in place with O-ring 2192, screw in screws 1041 and tighten them. (torque 150Nm)
16. Connect quench chamber, fill up fluid and vent the shaft seal.

ATTENTION

Possible damage to property

- Slide the screw spindles together onto the shafts.
- Before screwing in the spindle screws, wet both spindle screws 2180 at the spindle nuts with a thread-locking compound (factory uses Loctite 270).
- Observe the required tightening torques (Chapter 4)
- When replacing screw spindles, you will also need to synchronize them via the pinion gear drives (see Chapter 9.6)
- Keep the sliding surfaces free from dust and grease. Avoid any contact with the hands. If necessary, clean with a soft, clean cloth and acetone.

9.4.3 Double-acting mechanical seal

9.4.3.1 Disassembly of double acting mechanical seals

1. Relieve quench system or counter-pressure device, drain quench fluid.
2. Disassemble cover 1012.
3. Disassemble pump casing 1033.
4. Disassemble spindle screws 2180 and spindles (twin screws) 2200, 2201.
5. Remove inboard rotor holder 1303BC-80 incl. seal faces 1303BC-40 from the shafts. This will also disassemble O-rings 90, 130 and 220 as well as drive pins 210.
6. Loosen fitting screws 2259 and remove them along with washers 2260.
7. Remove the seal housing 1029 via the shafts.
8. Remove Inboard stators 11 on the front side from seal housing 1029. Remove O-rings 140.
9. Pull out outboard stators 12 from the seal housing via the rear side of the seal housing. Remove O-rings 140 and backup rings 170.
10. Remove disc rings 150 along with built-in drive pins 210 from the seal housing.
11. Pull off outboard rotors 20 from the shafts.
12. Remove wave rings 50 from the shafts.
13. Loosen the threaded pins of stop rings 110 and pull off the stop rings 60 incl. O-rings 30 and 160 from the shafts.

ATTENTION

Possible damage to property

- Equally clean the seal housing as well as the shafts and seal seats and carefully check the removed parts. Replace any damaged parts as well as all O-rings and shaft lip type seals.
- During disassembly be careful about the drive pins 210. If they get lost use new ones. Therefore use grease to stick them in the holes of the drive discs 150 and inboard rotor holders 80 respectively.

9.4.3.2 Assembly of double acting mechanical seals

see following pages.

Assembly of double Acting Mechanical Seals



Step 1: placing O-Rings

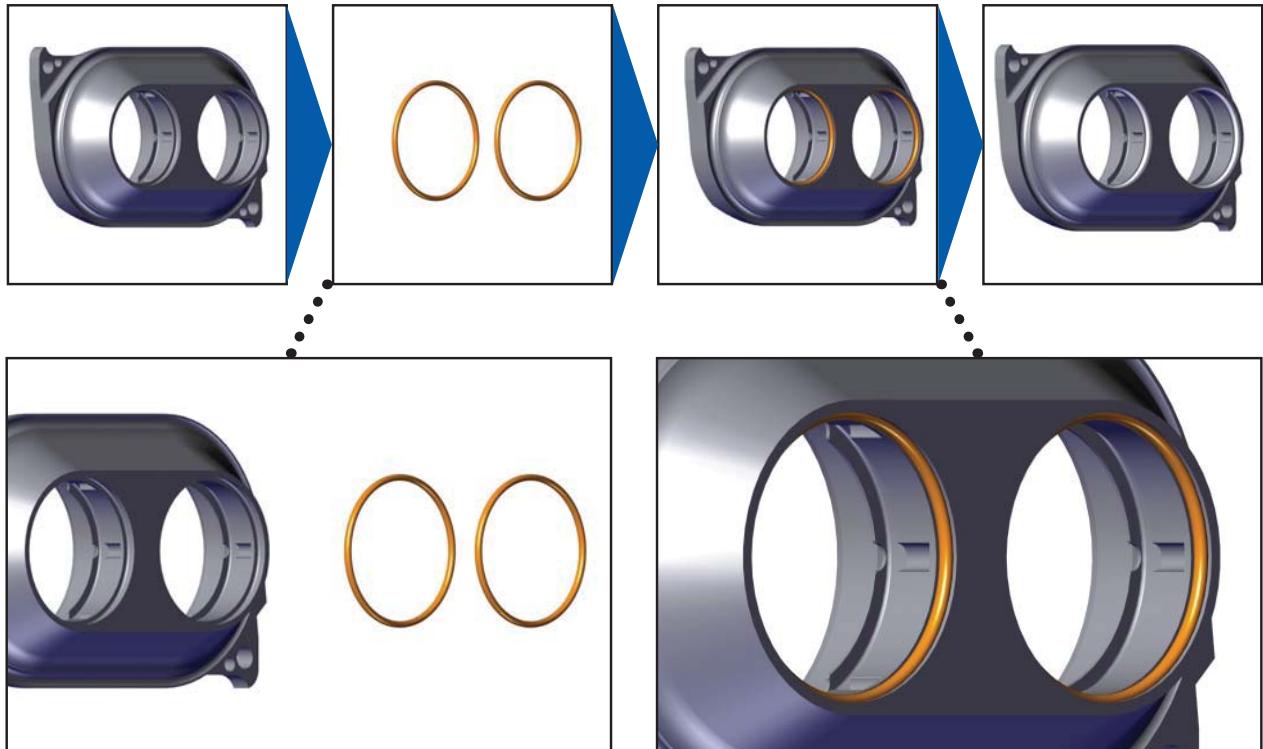

Tool/ Components:

- Food Grade Grease
- Cleanser
- Cleaning-Cloth
- O-rings 58x3 Pos.3 (2x)

Steps:

- Clean O-ring grooves
- put lubricant on O-rings (thin layer only)

Assembly of double Acting Mechanical Seals



Step 2: placing seal-faces on product side

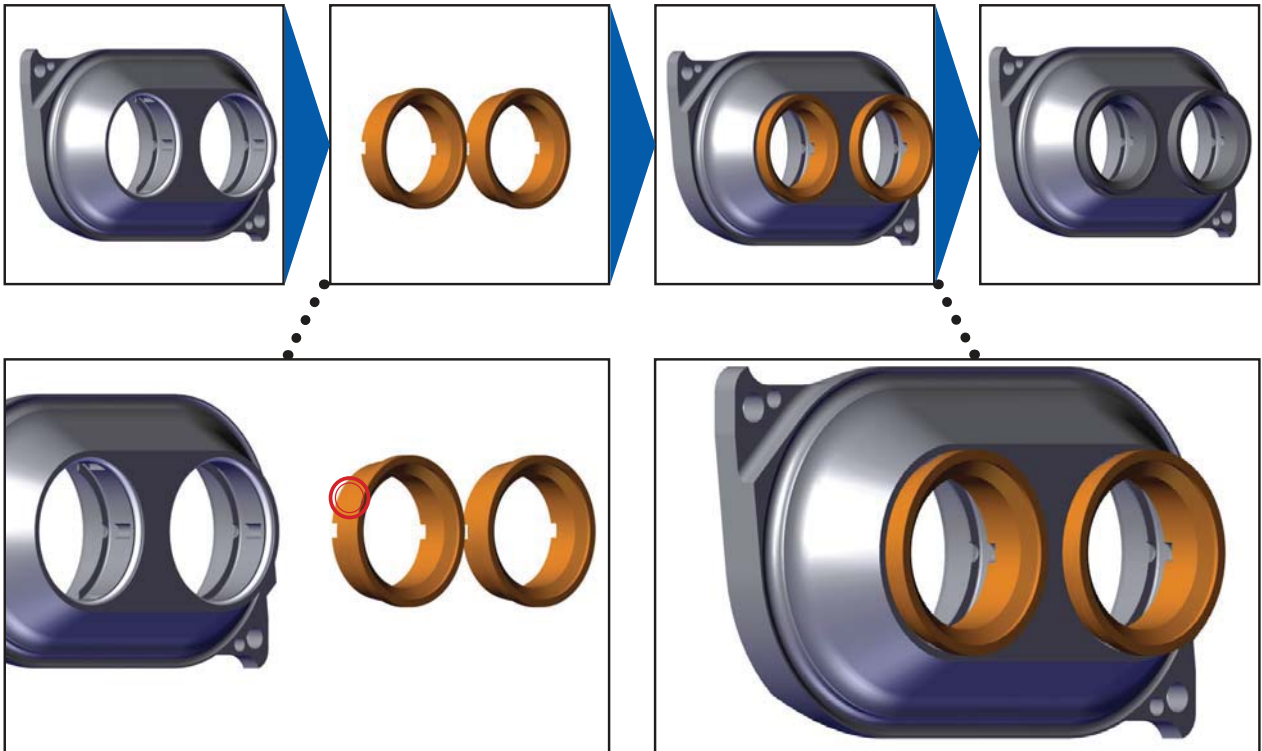

Tools / Components:

Lubricant

SealFace Pos. 1 (2x)

Steps:

Outer surface of seal faces cover with thin layer of lubricant

Carefully place the seal faces straight into place. Grooves need to fit over cross.

Caution:

Front of seal face is delicate, do not use tools. Scratches will lead to leakage.



Step 3: set pressure rings

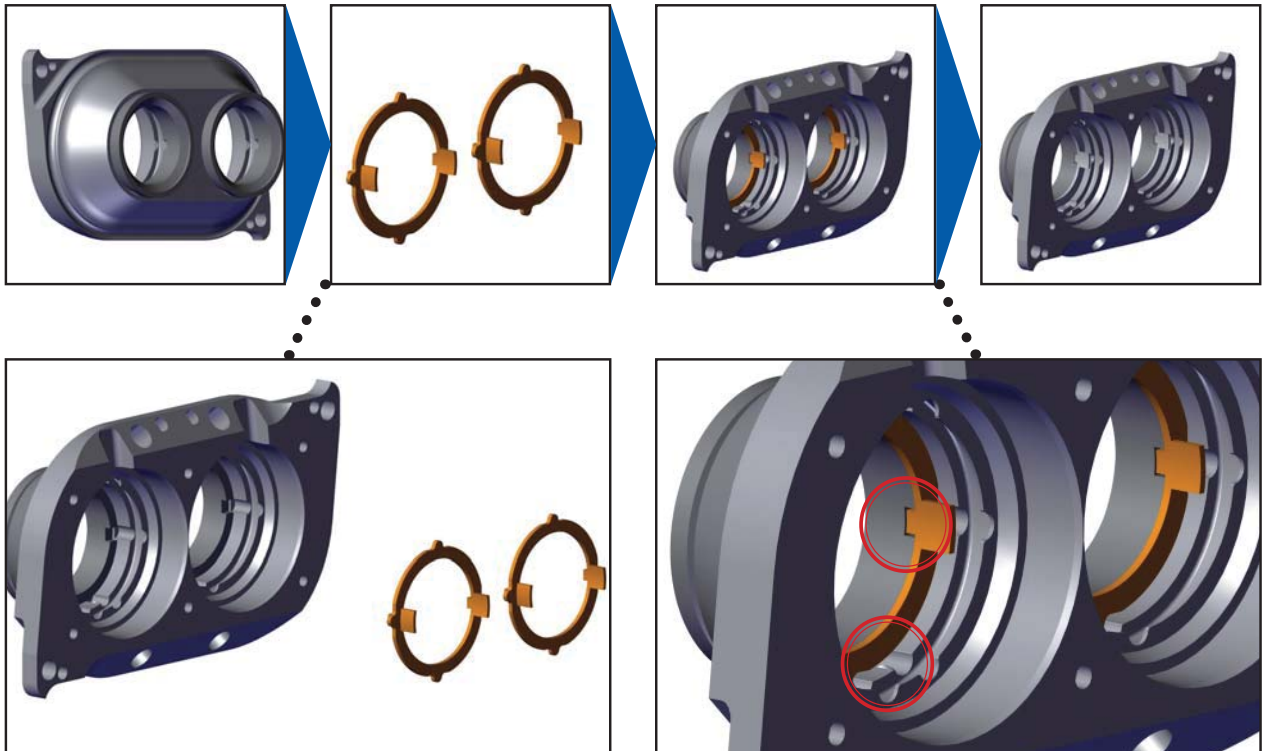

Tools / Components:
Pressure Ring Pos. 7 (2x)

Steps:

Place pressure ring into grooves
place into grooves in positions:

12-3-6-9

Keep flushing grooves clear!

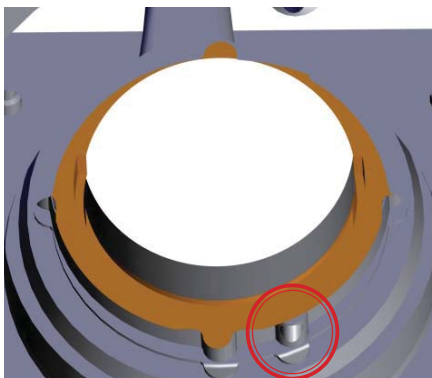



Step 4: place plastic safetyrings

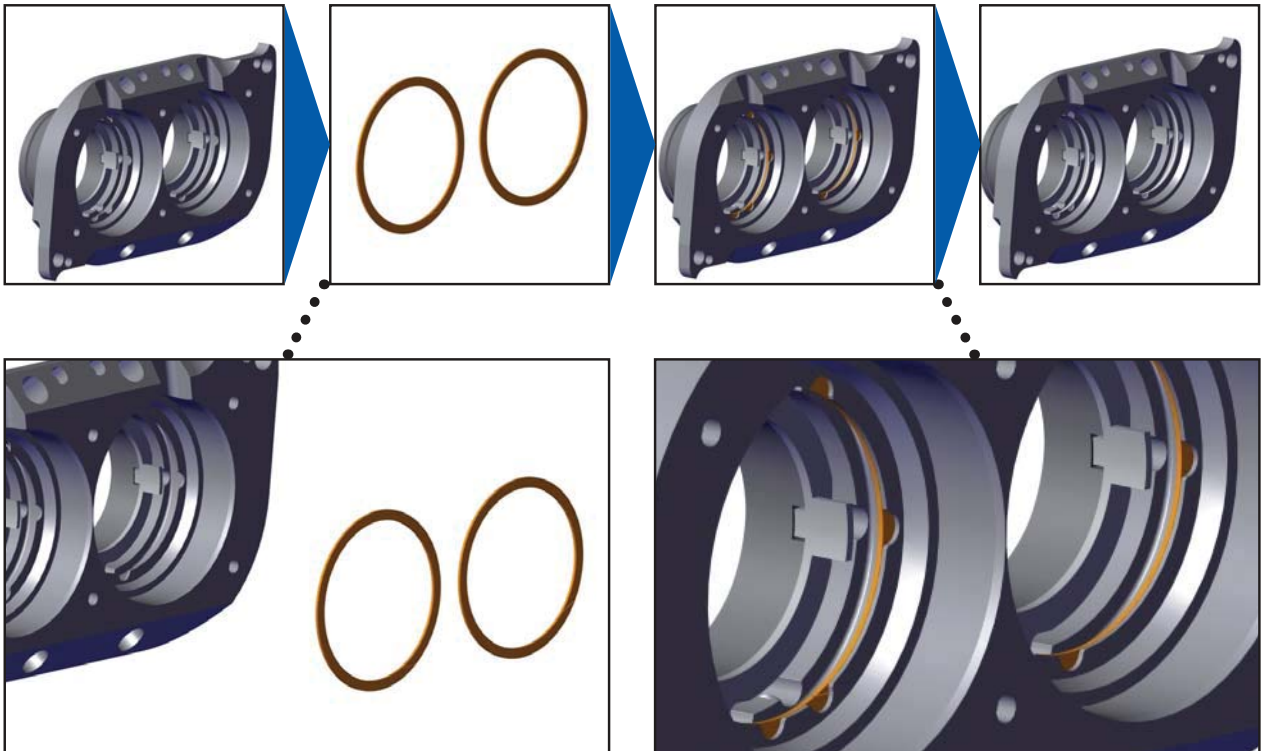

Tools / Components:

Safety rings Pos.13 (2x)

Steps:

Clean grooves thoroughly

insert safety rings and insure snug fit to rim

Do not rip safety ring apart

Assembly of double Acting Mechanical Seals



Step 5: place O-Rings 43x2

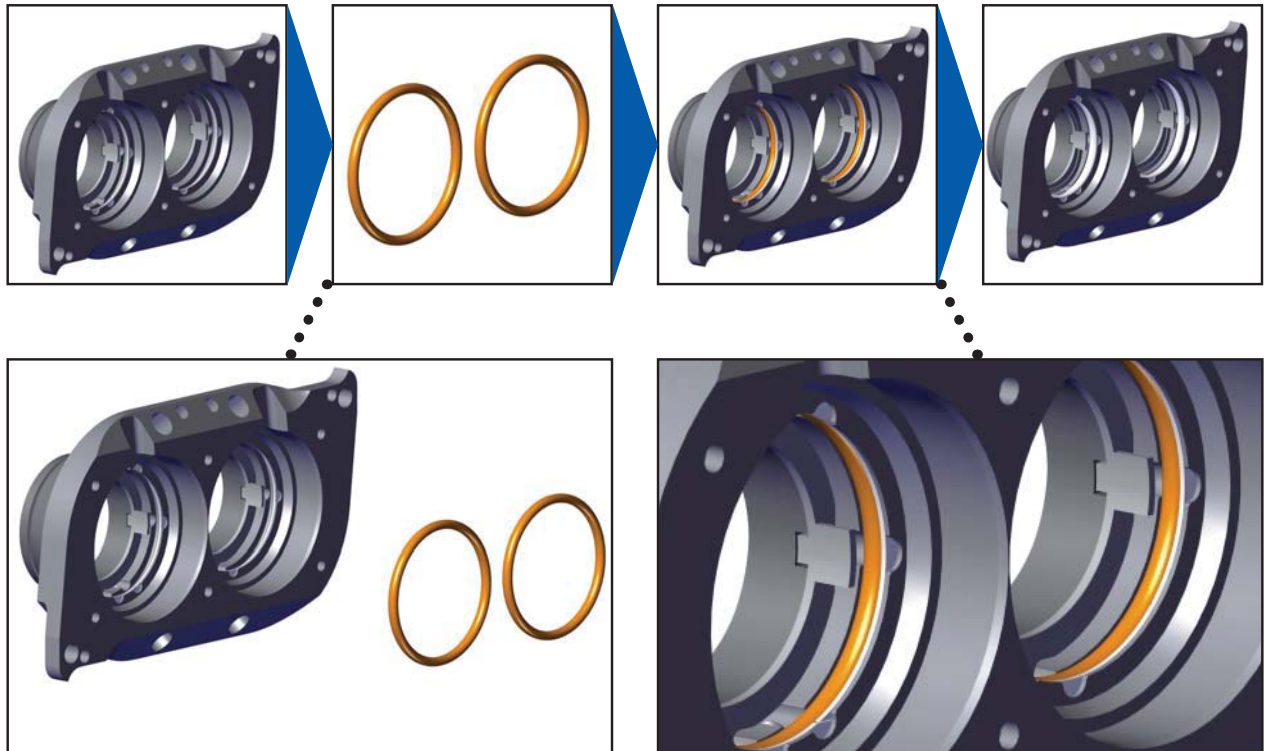

Tools/Components:

O-Rings Pos. 4 (2x)

Steps:

Place O-ring behind safetyring

Assembly of double Acting Mechanical Seals



Step 6: place sinus-spring 43x2

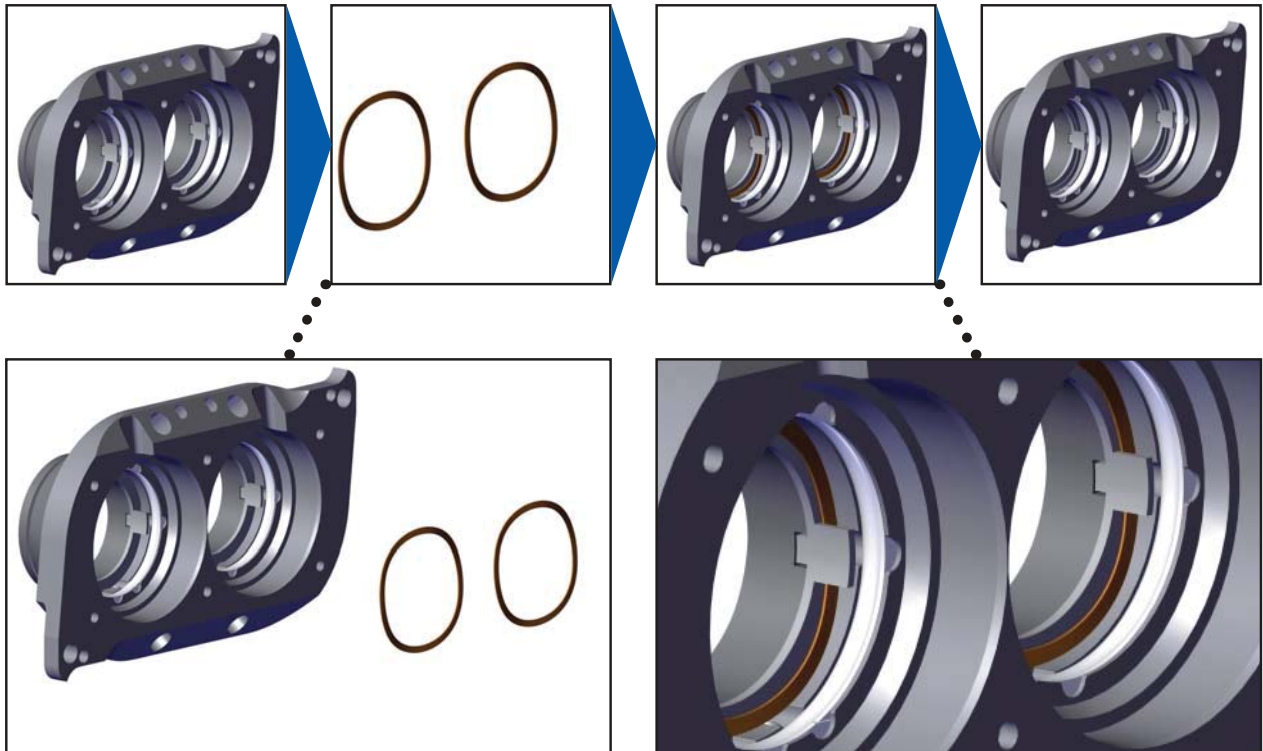

Tools / Components:
Sinus spring Pos. 8 (2x)

Steps:
Place Sinus spring at Pos. 8

Assembly of double Acting Mechanical Seals



Step 7: place seal face atmospheric

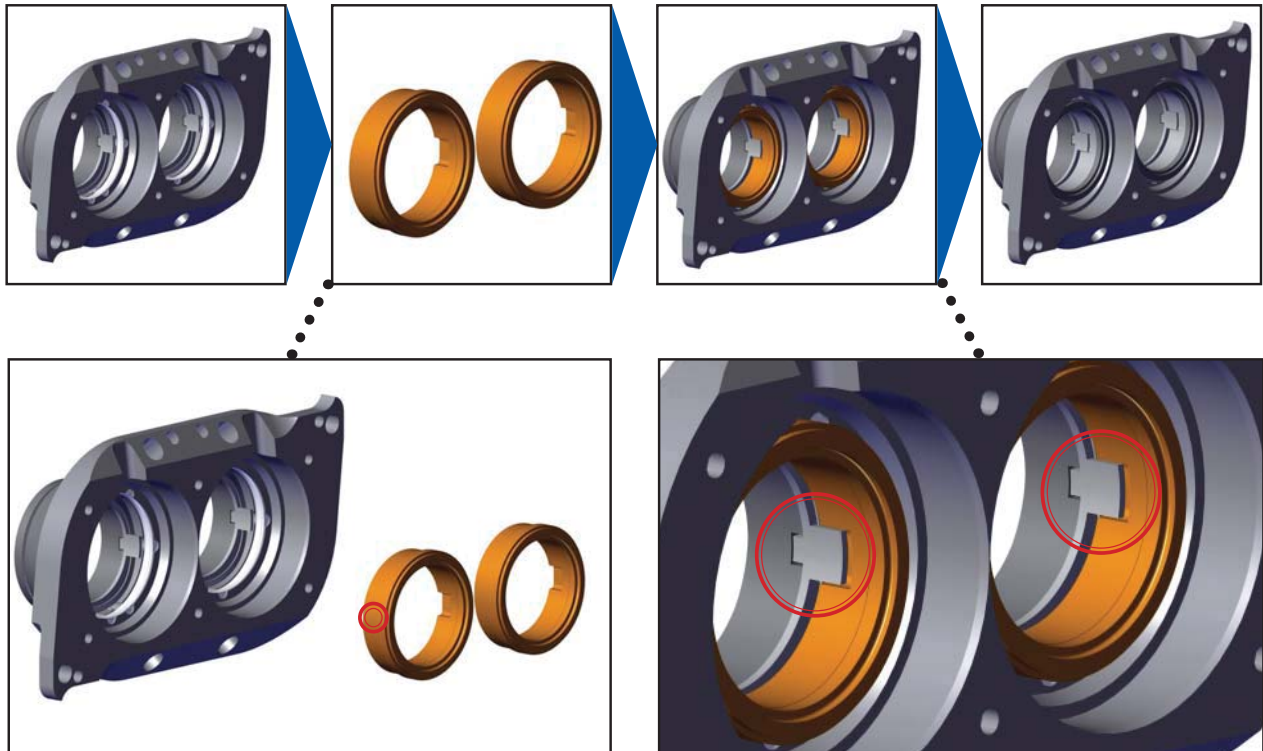

Tools / Components:

Seal faces Pos. 2 (2x)

Steps:

Put a thin layer of lubricant on the outside of the seal face.
Place seal face (Pos.2) the way the groove of the seal face fits the cog of the pressure ring (Pos.7) on both sides accurately

Assembly of double Acting Mechanical Seals



Step 8: mounting locking plate

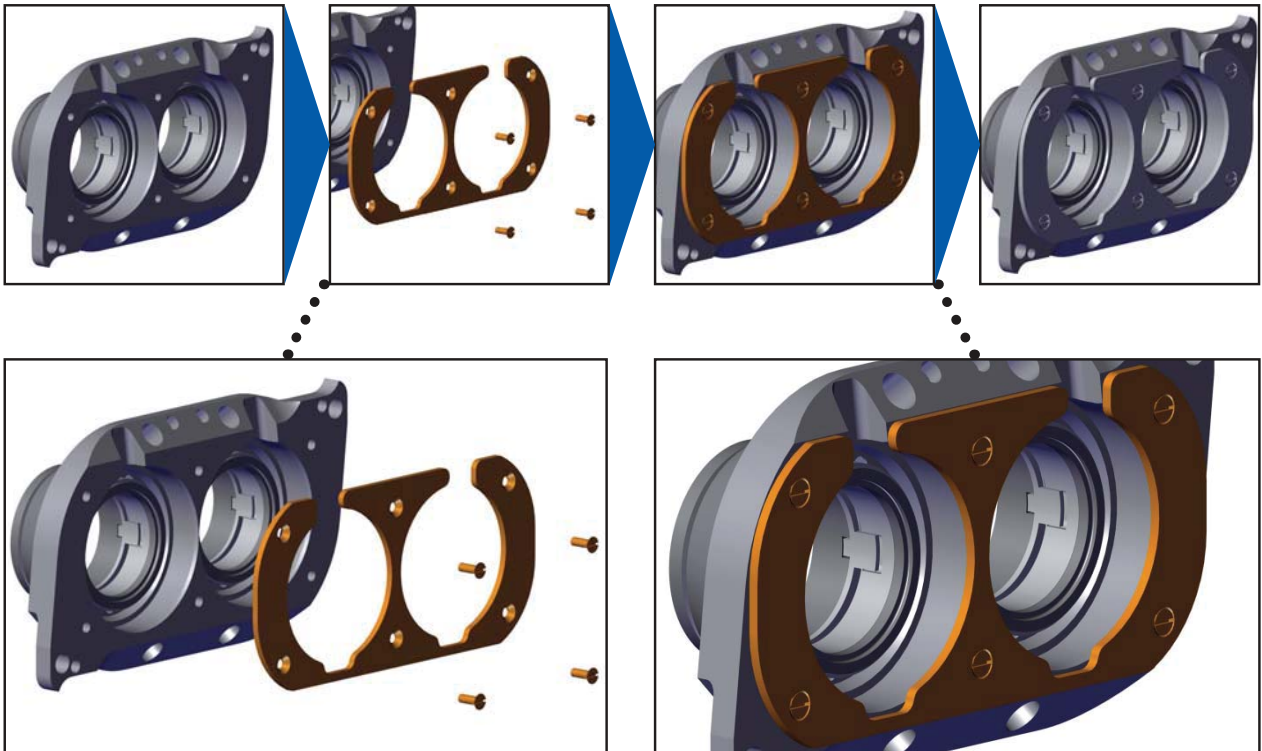

Tools / Components:

Screw driver
Lubricant

Cleanser/Cleaning Cloth
Locking plate 2324
countersunk head screws 2325

Steps:

Lubricate countersunk head screws
Clean locking plate
mount locking plate 2324 on sealing body 1029
with countersunk head screws
torque to 7.375 lb/ft (10 Nm)

Assembly of double Acting Mechanical Seals



Step 9: mounting of flushing-sockets

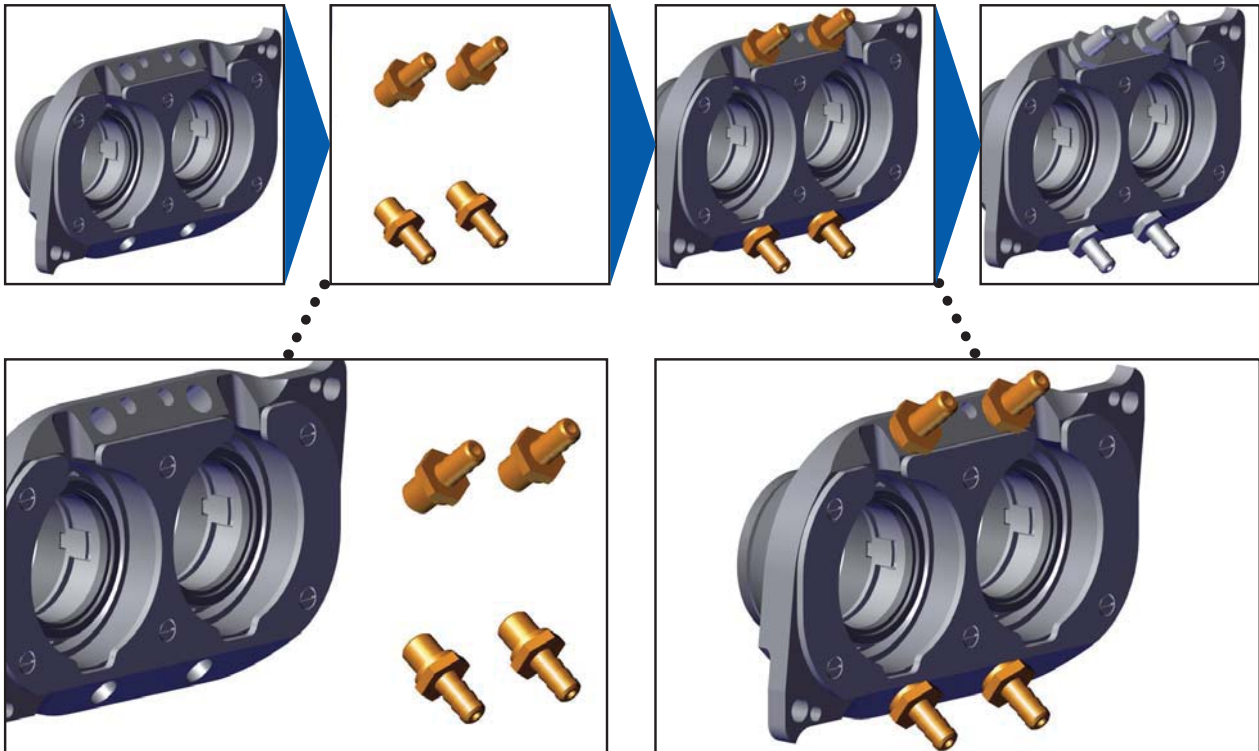

Tools / Components:

Teflonband (for sealing)

Wrench SW19

for double acting mechanical seals:
Flushing hose-sockets 1864 (4x)

For single acting n=mechanical seals:
Lamellar plugs 1966 (4x)

Steps::

Wrap some Teflon band around the outer thread of the nipples. (Depending on the sealing type, a different connection might be applicable:

- Double acting mechanical seal
- single acting mechanical seal

Torque to :14.750 lb/ft |(20Nm)



Step 10: Mounting of guard plate

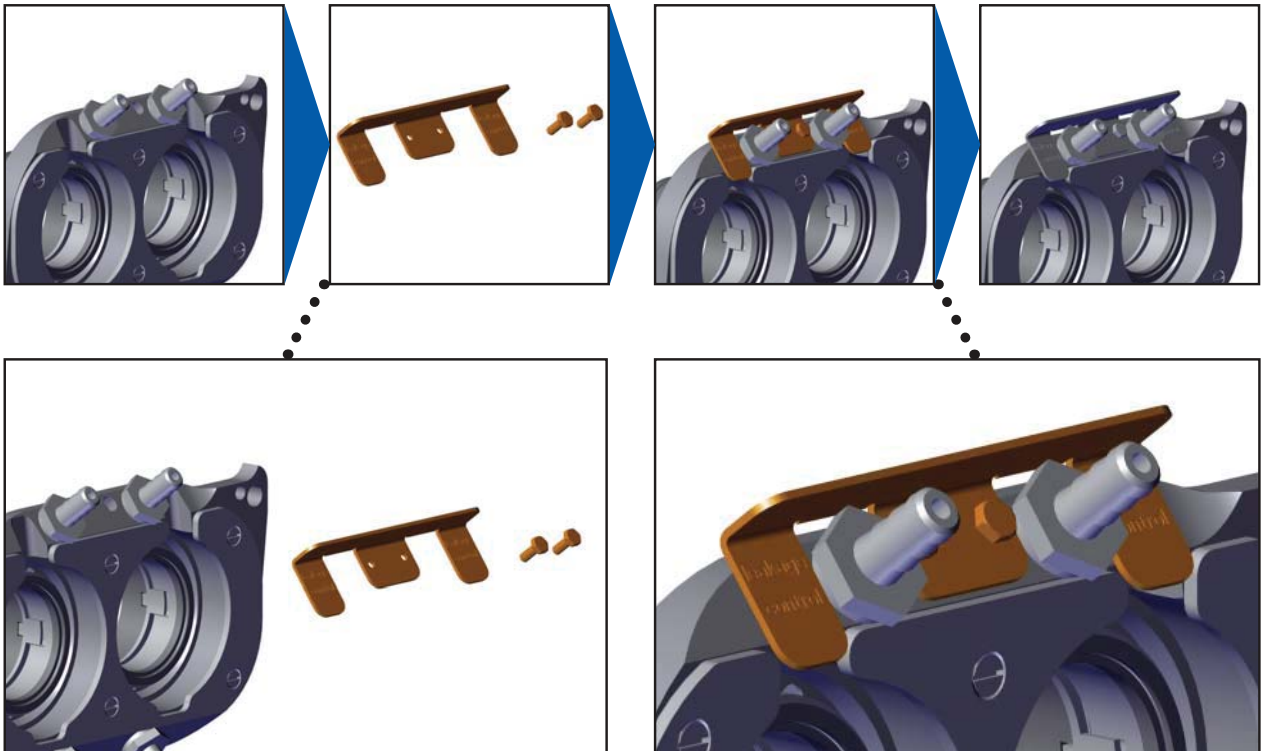

Tools / Components:

Loctite, blue (medium hard))
Wrench SW8

guard plate 2286
Hexhead bolt 2287 (2)

Steps:

Drip a small amount of loctite blue
on hexhead thread

Torque: 7.375 lb/ft (10Nm)



Step 11: mounting of stationary seat rings

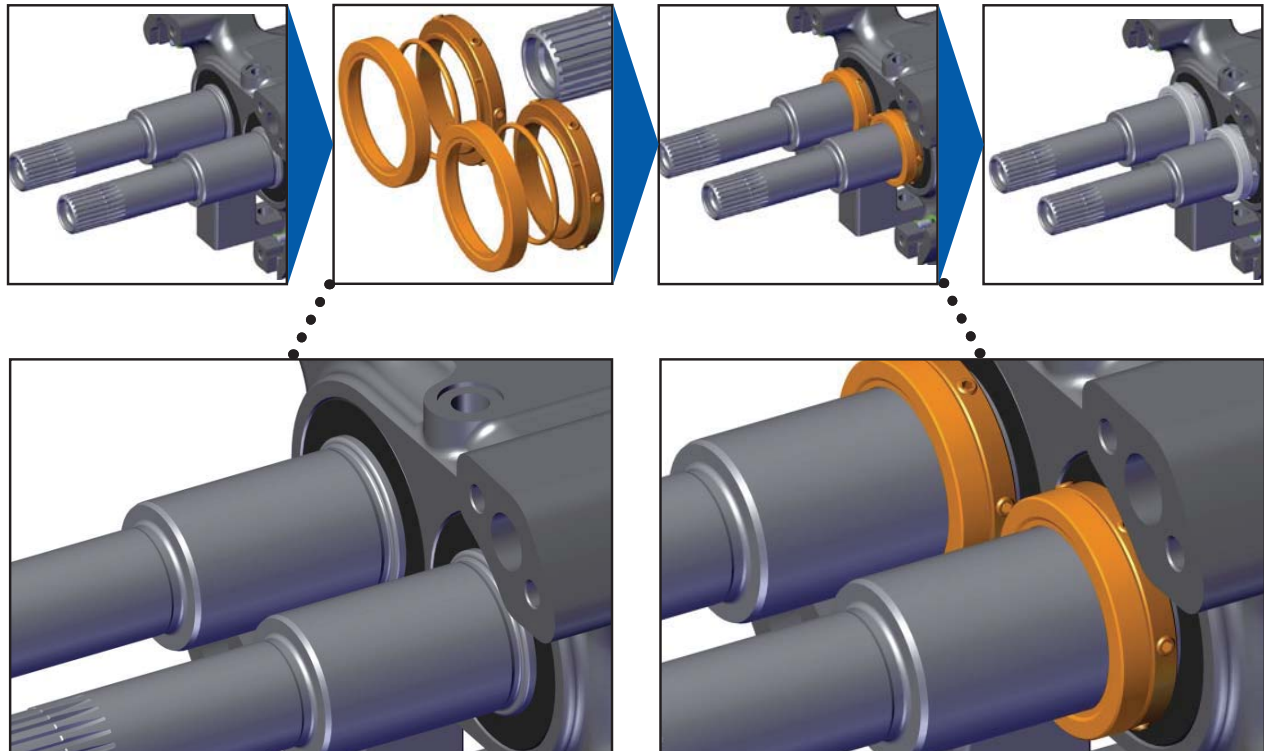

Tools / Components:

Allen key 2,5 Loctite
blue (medium strength)
Stationary Seat rings
Pos. 6; 11;14; 15

Steps:

Position stationary seal rings to
suspension point .
Lubricant threads of set-screws.

Caution: tigh the set crews cross wise

Torque: 3.68 lb/ft (5Nm)



Double Acting Mechanical Seal



Step 12: set sealing body in place

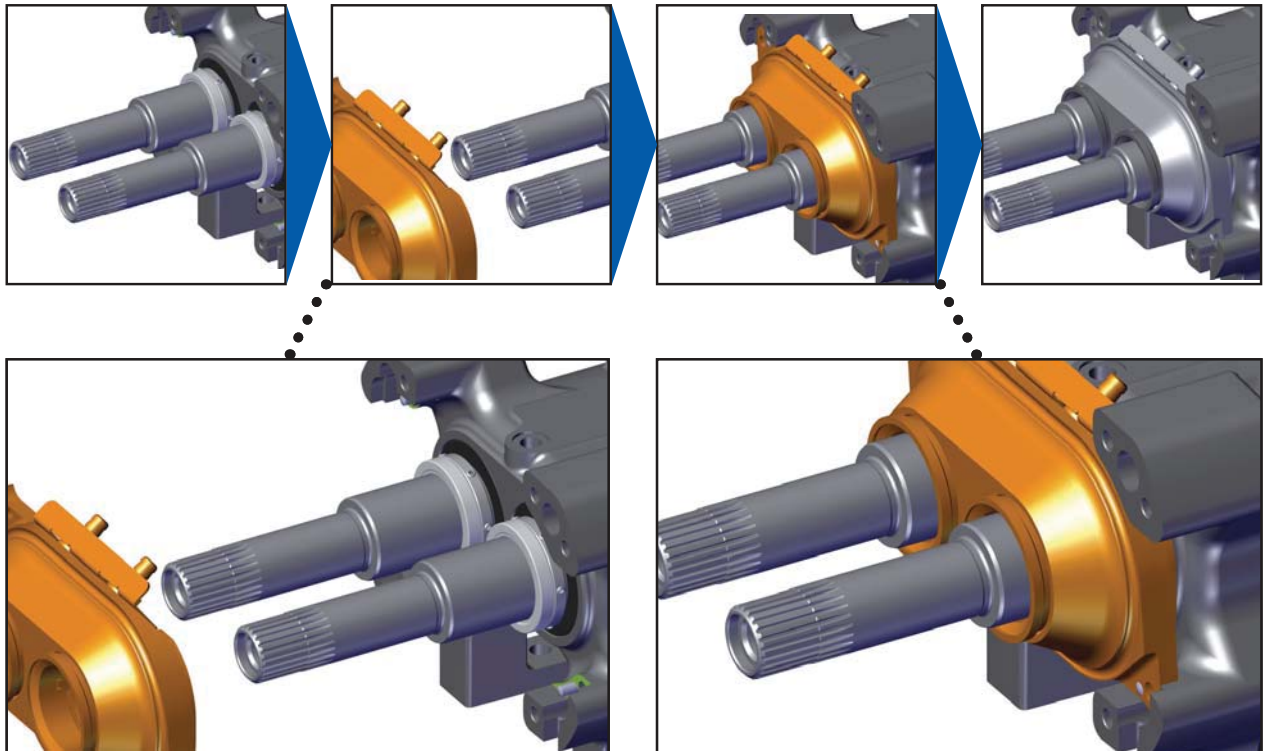

Tools / Components:

Double acting mechanical seals premounted
cleanser & cleaning cloth

Steps:

Degrease and clean seal face surfaces Pos.2 + Pos.6

Implement sealing body

Assembly of double Acting Mechanical Seals



Step 13: tighten sealing body on bearing housing

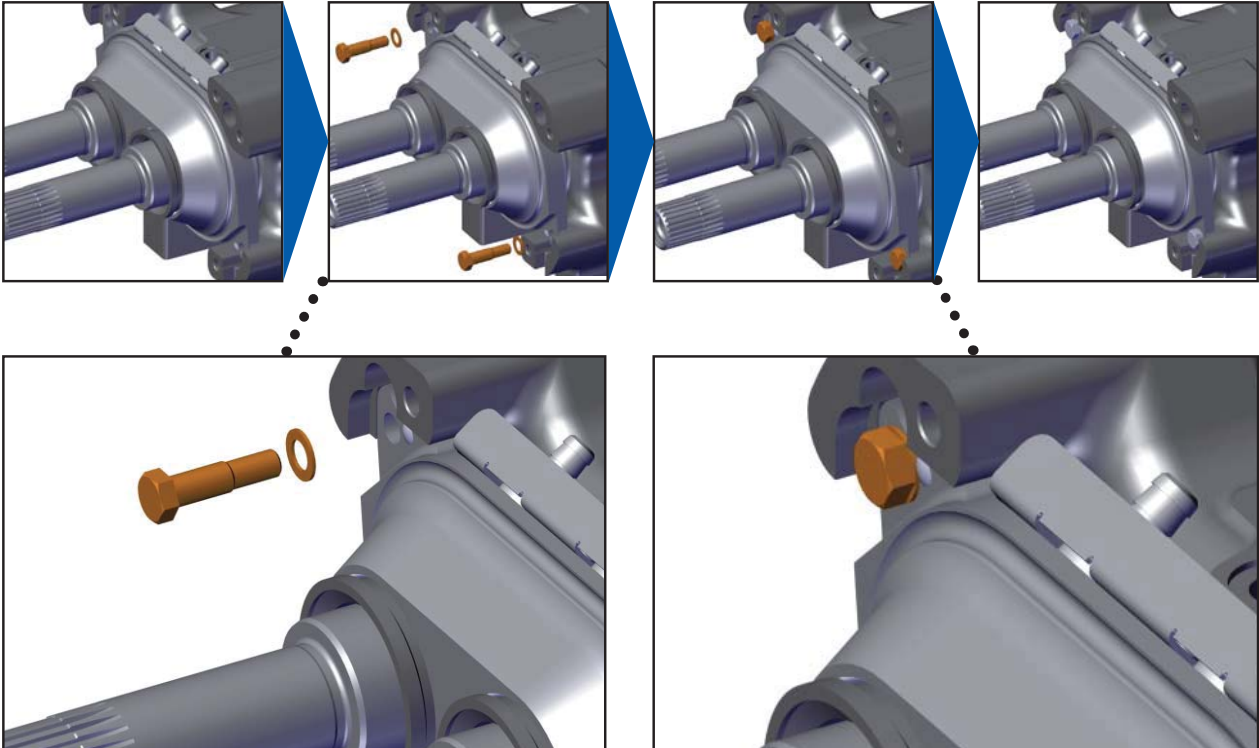

Tools / Components:

Socket wrench
socket SW13 Dowel
screw 2259 (2x)
Washer 2260 (2x)

Steps::

screw in dowel screw and washer in
the bearing housing 2276

Torque to :59 lb/ft (80Nm)



Step 14: position insert ring

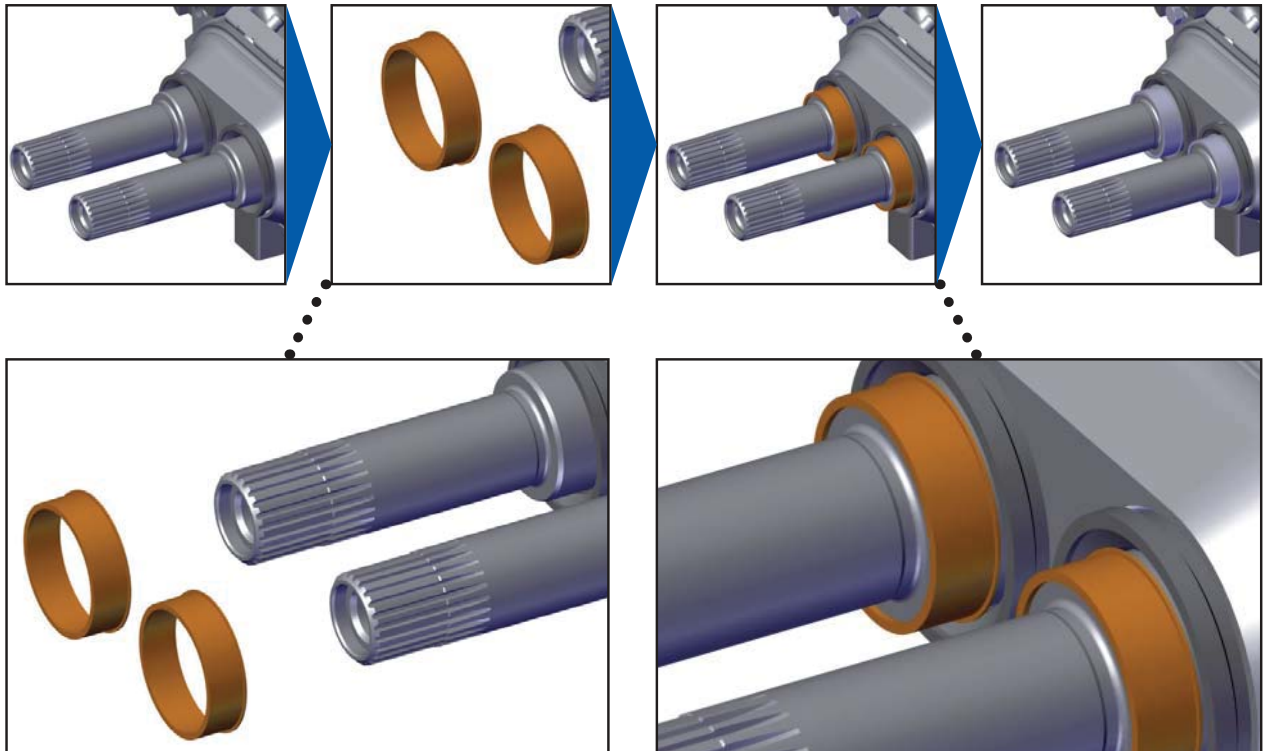

Tools / Components:

- Cleanser
- Cleaning Cloth
- Lubricant
- Insert ring Pos.16 (2x)

Steps:

- Clean insert rings
- clean drive shafts
- Lubricate joining area
- position insert rings

Assembly of double Acting Mechanical Seals



Step 15: mounting of seal faces on product side

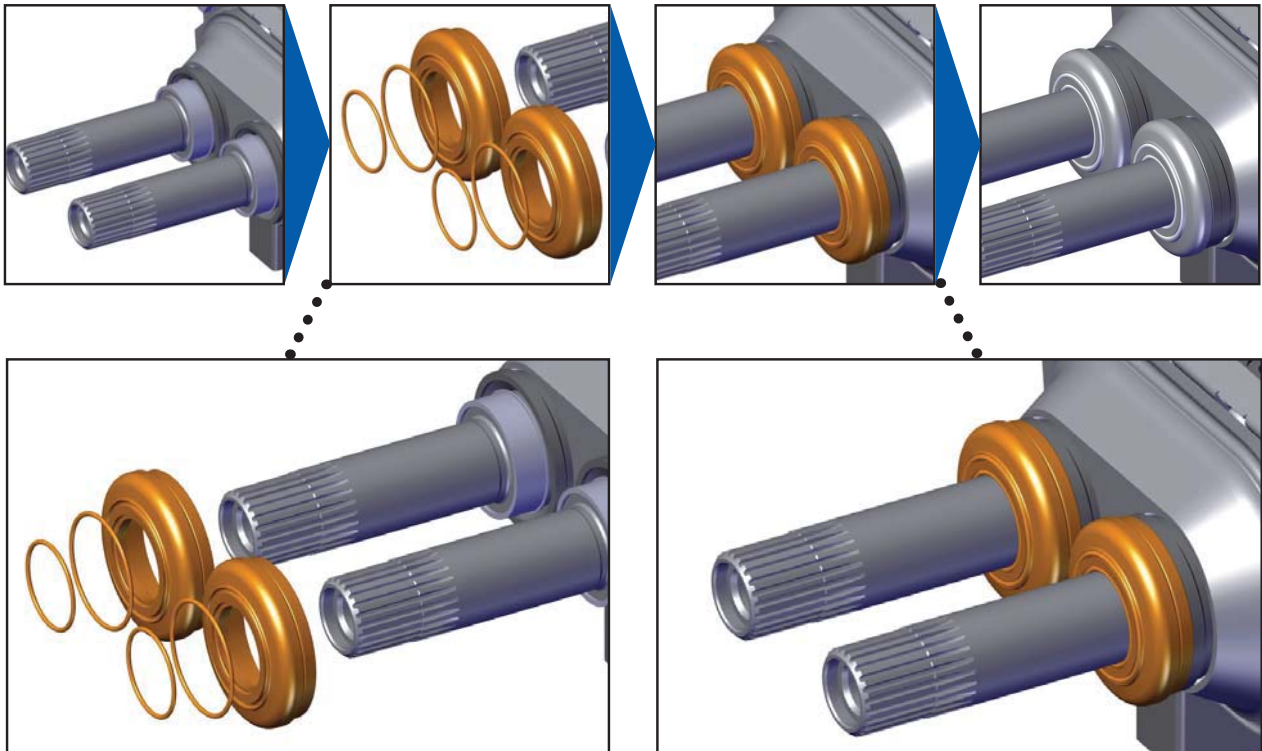

Tools / Components:

Cleanser/
cleaning cloth
Lubricant
O-ring Pos. 9 (2x)
O-ring Pos 12 (2x)

O-ring Pos. 3 (2x)

Sealing housing Pos. 10 (2x)
Rotating seal face Pos. 5 (2x)
Pins Pos. 17 (4x)

Steps:

Lubricate O-ring Pos. 9 and Pos. 12
Insert O-rings Pos. 9 and Pos. 12 in the
seal face housing Pos. 10 .

position seal face housing on drive
shafts until snug fit
Pos. 9;12;3;10;5;17

Caution: degrease seal faces before
positioning seal face housing Pos. 5
This step is important to prevent from
braking seal faces due to extended
period of non-operating the pump.

Assembly of double Acting Mechanical Seals



Final checklist

- | | | | | | | | |
|-----------------------------------|--|-----------------------------------|--|-----------------------------------|--|-----------------------------------|--|
| <input type="checkbox"/> 1. Step | | <input type="checkbox"/> 2. Step | | <input type="checkbox"/> 3. Step | | <input type="checkbox"/> 4. Step | |
| <input type="checkbox"/> 5. Step | | <input type="checkbox"/> 6. Step | | <input type="checkbox"/> 7. Step | | <input type="checkbox"/> 8. Step | |
| <input type="checkbox"/> 9. Step | | <input type="checkbox"/> 10. Step | | <input type="checkbox"/> 11. Step | | <input type="checkbox"/> 12. Step | |
| <input type="checkbox"/> 13. Step | | <input type="checkbox"/> 14. Step | | <input type="checkbox"/> 15. Step | | | |

Chapter 9

9.4.4 Bearing

Disassembly:



- For this purpose, the following pump elements need to be removed before: drive, coupling elements if necessary, gear housing, cover, pump casing, screw spindles, and shaft seal.
- Disassembled bearings need to be replaced with new ones during the assembly work.



- Be sure to mark the position of the gear wheels to one another now.
- Only loosen screws 2186 when disassembling the gear wheels if the installation of new shafts, screw spindles or a new basic setting of the pump is being intended.

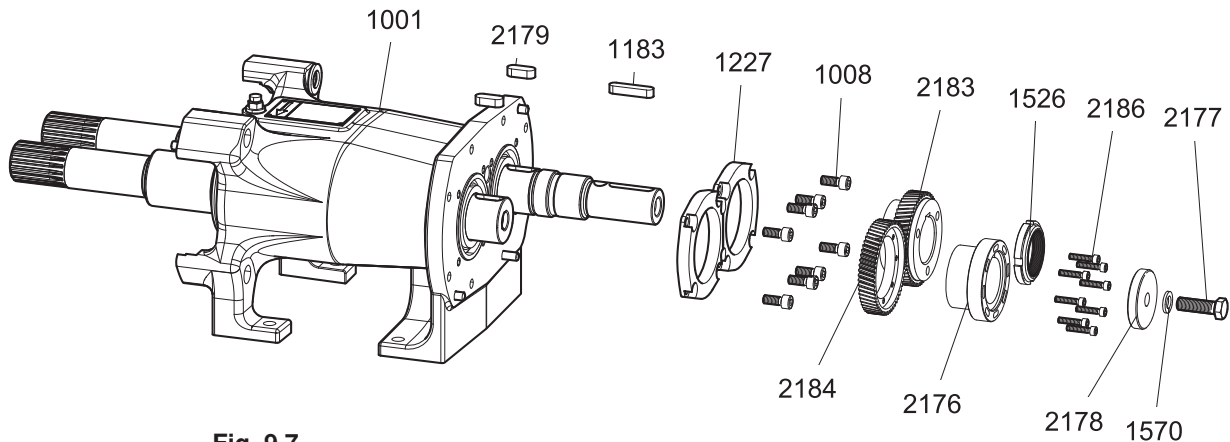

Fig. 9.7

Special tools:

Hook spanner for shaft nut, steel mandrel for counter holding, assembly press, various mounting sleeves

1. Loosen hexagon screw 2177 of driven shaft 2171 and remove it incl. washer 2178.
2. Pull off gear wheel 2184 incl. hub 2176 from the driven shaft.
3. Loosen and remove shaft nut 1526 of the drive shaft (counter hold via the locking hole in the shaft using a steel mandrel).
4. Remove gear wheel 2183 from the shaft.
5. Remove and store keys 2179.
6. Loosen cylinder head screws 1008 of bearing caps 1227 and remove the bearing caps.

Chapter 9

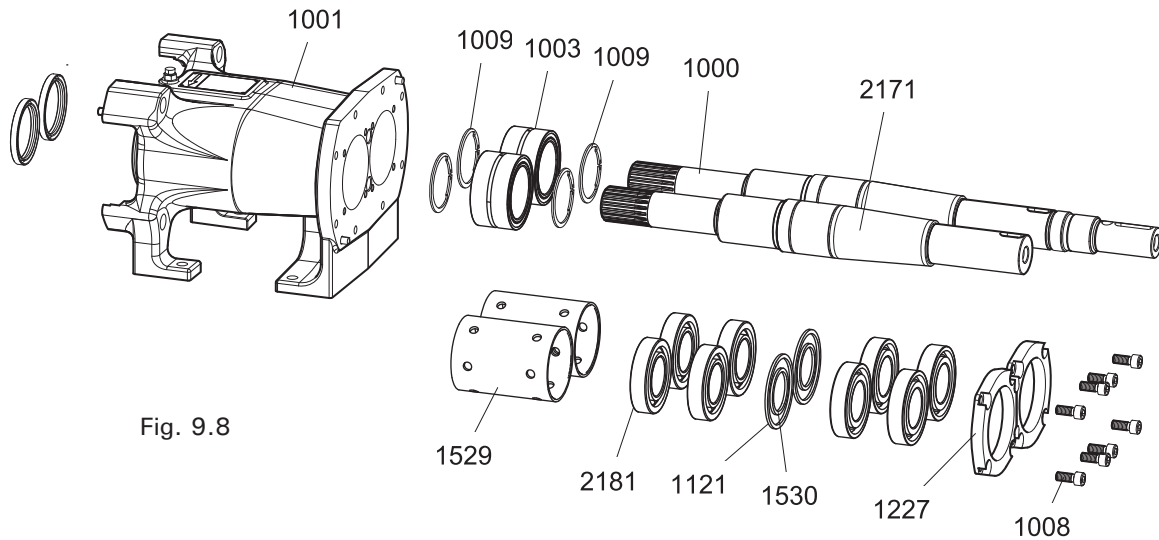

Fig. 9.8

7. Using a press, press out the shafts incl. bearings and distance rings toward the drive end. Afterwards, remove locking rings 1009 and remove the needle bearings from the shaft using an extractor tool. Next, pull out angular ball bearings 2181 from the shaft one after the other and remove distance rings 1530, 1121 and spacer rings 1529. Remove spacer rings 1529 and using a puller, pull out the outer race of the needle bearings from the bearing housing.
8. Press out shaft sealing rings 1010 from the pump casing.

ATTENTION

Possible damage to property

- Carefully equally clean the drive shafts and gear wheels. Replace worn parts.

Installation:

1. Place the housing of the bearing bracket onto the press bed
2. Grease the bearing surfaces of the housing. (See Chapter 4 for assembly grease)
3. Likewise apply lubricating agent onto the shafts in the region of the bearing positions.
4. Insert inner snap rings 1009 into the shafts. Press inner sleeves of needle bearings 1003 onto the shafts using a pressure sleeve. Slide on needle bearings. Mount outer snap rings 1009.
5. Place distance tube 1529 onto the shaft.
6. Press 2 each angular ball bearings 2181 one after the other and individually onto the shaft. (Heed installation position, in double O arrangement) (press only the inner races of the bearings) Place distance rings 1521 and 1530 into the middle between the 4 angular ball bearings.
7. Carefully insert the drive shaft incl. fitted bearings into the bearing housing and carefully press fit the shaft with its bearings all the way up using the press and a mounting bush that only presses onto the outer race of the bearing. The last bearing will then only protrude approx. 1 mm from the bearing housing.

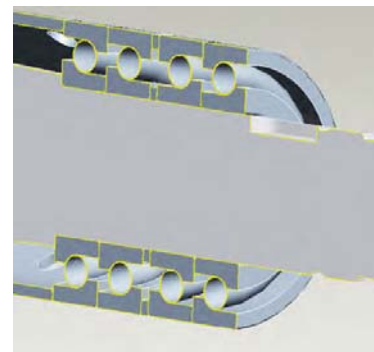

Fig. 9-9 Angular ball bearing in O arrangement

Chapter 9

ATTENTION

Possible damage to property

- **Align the distance bushes and rings precisely when pressing them in otherwise they will be destroyed.**
8. Install the driven shaft in similar way.
 9. Into the bearing housing new shaft seals 1011 press with a mounting sleeve. (The spiral ring of the sealing lip shows in the pump housing).
 10. Insert both bearing covers 1227, apply thread lock fluid onto cylinder head screws 1008 (factory uses Loctite 270), screw them in and tighten. M8 torque = 20 Nm.
 11. Lubricate shaft sealing rings 1111, slide them over the toothed shaft ends and carefully fit them into the seat in the bearing housing using a mounting tube (tube D = 75, d = 61, L= 225).
 12. Insert keys 2179 into the shafts on the drive side.
 13. Slide gear wheel 2183 onto the drive shaft, screw in and tighten shaft nut 1526 (torque 90 Nm).
 14. Slide gear wheel 2184 incl. hub 2176 onto the driven shaft. (Observe mark)
Screw in and tighten screw 2177 incl. washer 1570 and lock washer 2178 (torque 80 Nm).

ATTENTION

Possible damage to property

- **Place a bronze or copper bar into gear teeth of the gear wheels when tightening screw 2177.**
 - **Do not use hard metals, such as pry bars or steel bars keeping the sensitive tooth flanks in mind.**
15. Place on gear housing 2172 incl. gasket 2198 (housing being centred through dowel pins), screw in and tighten cylinder head screws 2258. (Torque 20 Nm).
 16. Install shaft seal and screw spindles, mount pressure housing (Torque 150 Nm). Install suction housing (torque XY).
 17. Mount driving elements (coupling guard).
 18. Fill in gear oil. Check the oil level via the sight glass.

Chapter 9

9.5 Adjusting screw spindles.

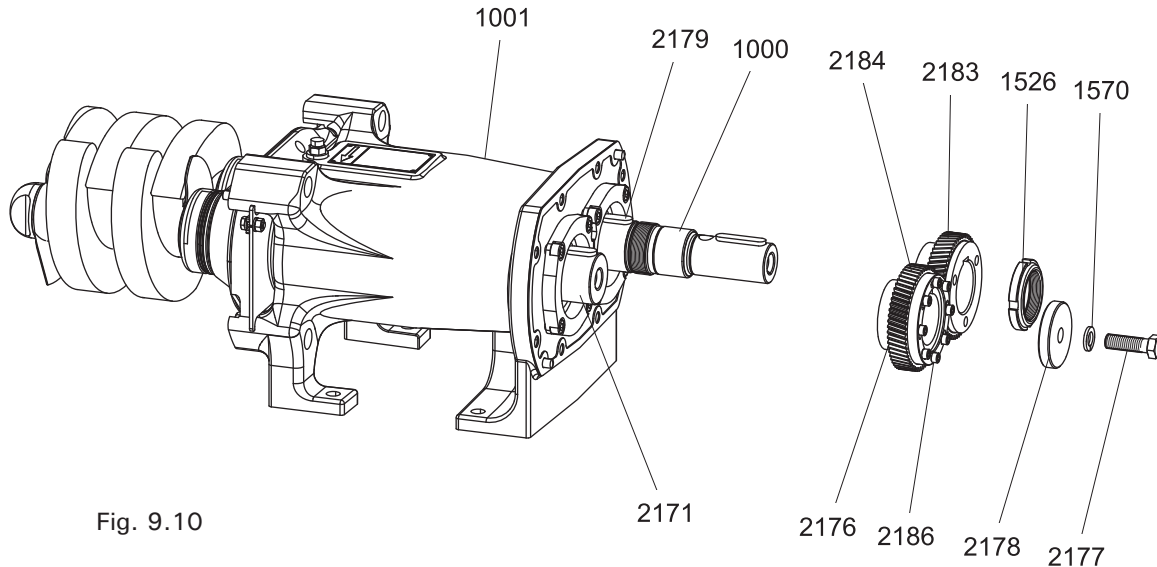

Fig. 9.10

Installation:

1. Insert keys 2179.
2. Slide gear wheel 2183 onto the drive shaft 1000, screw on and tighten shaft nut 1526. (Tightening torque 70 Nm for M35, 90 Nm for M45) (Plug steel mandrel through the shaft hole counter holding with it while tightening the shaft nut).
3. Slide on gear wheel hub 2176 incl. gear wheel 2184 onto driven shaft 2171. Turn the gear wheel on the hub until the holes of hub and tapped holes of the gear ring check. (Tapped hole is positioned roughly in the middle of the oblong hole). Note the inclined position of the gear ring.
4. Screw in cylinder head screws 2186 by hand.
5. Place lock washer 2178 onto the driven shaft, screw in and tighten hexagon screw 2177 incl. spring ring 1570. (Torque 80 Nm).

ATTENTION

Possible damage to property

- Place a bronze or copper bar into gear teeth of the gear wheels when tightening screw 2177.
- Do not use hard metals, such as pry bars or steel bars keeping the sensitive tooth flanks in mind.

Chapter 9

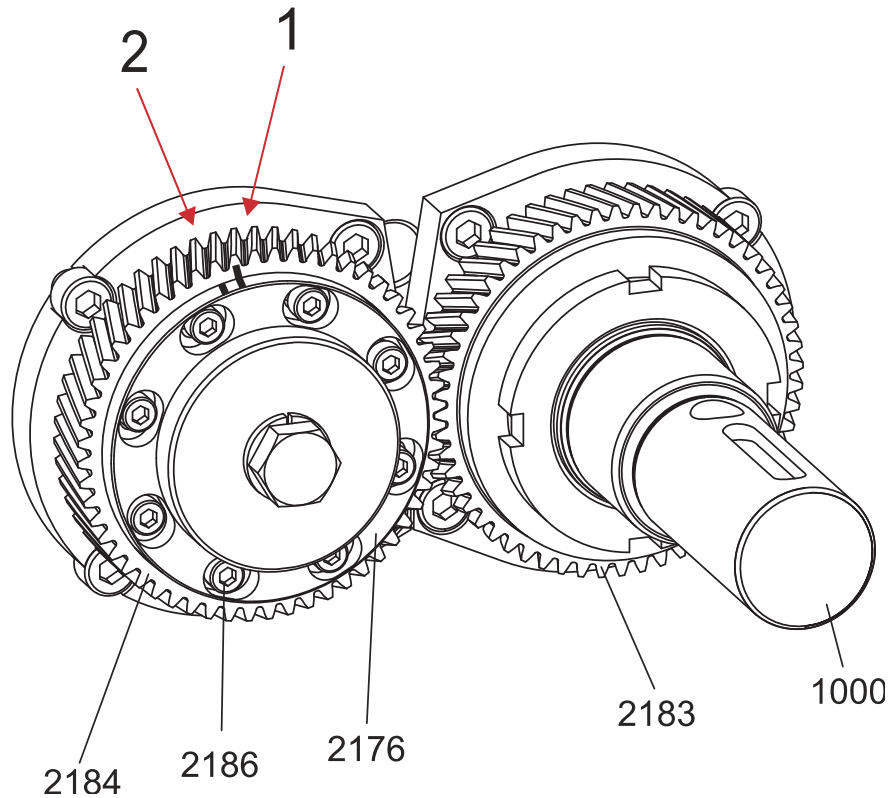

Fig. 9.11

Adjustment:

1. Turn drive shaft 1000 until the spindles stop.
2. Mark this position on gear wheel hub 2176 and driven gear wheel 2184.
3. Now turn the drive shaft into the opposite direction until the spindles jam.
4. Mark this position on gear wheel hub 2176, too.
5. Turn back the drive shaft by a half of this mark. The screw spindles are freely moving now.
6. Now tighten cylinder head screws 2186 crosswise in alternating fashion.



- Tightening torque of the cylinder head screws = 8 Nm

Chapter 10

10. Stocking of spare parts

10.1 Spare parts

Wear and hence the life-cycle of the major pump components are essentially influenced by a variety of factors, such as:

- Working pressure,
- Temperature,
- Properties and condition of the pumping medium,
- System operating times.

We recommend stocking up the major spare parts as per table below. You will thus reduce the MTRR values (Mean Time to Repair) (recommendation acc. to DIN 24296).

Number of same pumps per system section			
Spare parts	P-number	up to 2 pumps	from 3 pumps
Gear housing shaft sealing ring	1010	1	up 2
Bearing housing shaft sealing ring	1111	2	4
Pump casing O-ring	1088	1	2
Spindle nuts O-ring	2194	4	8
Cover O-ring	2192	1	2
Gear housing gasket	2198	1	1
Shaft seal, set of O-rings	2261	2	4
Gear ring	2249	1	2
Gear oil, 1 L	2294	1	2

(*) depending on pump model chosen (see data sheet)

ATTENTION

Possible damage to property

- **Use only original ViscoTwin spare parts to avoid any adverse effects on the functionality of your pump.**

10.2 Ordering spare parts

- Please report to your personal contact at ViscoTec or report to ViscoTec by means of phone, facsimile or email (number and email adress see below).
- A pump specific spare part list and/or pump specific spare part explosion drawing is provided by ViscoTec as part of technical documentation together with the ViscoTwin pump or prior to delivery on request. Please provide [eData-ID](#) of pump and of spare part to order when ordering. [eData-IDs](#) are listed in [both spare part list and explosion drawings](#).
- If [eData-ID](#) is not known, please indicate serial number, type and configuration code of ViscoTwin. Required data are on the pump type label. Most convenient way to collect required data from pump type label is by means of the QR code, which can be read by means of most QR code readers, e.g. on a smart phone. No liability will be assumed for wrong deliveries on account of insufficient data.

Where to order:	ViscoTec, Inc.	Telephone:	+1(559) 429-4227
	933 W Hemlock Ave	Fax:	+1(559) 429 4228
	Visalia, CA 93277	E-mail:	info@viscotec.com

Appendix

- **Tools required for maintenance and servicing**
- **Explosion drawing with index**
- **The Engineering Design and Technical Construction File**
 - o **CIP | SIP | Manual Cleaning**
 - o **Oil change**
- **Tightening torque values**

Tools required for maintenance and servicing

Maintenance and servicing of ViscoTwin 104 requires tools as listed in tables below.

Definition of maintenance levels

All tools required are categorized by maintenance levels ranging from 1 to 3, whereas maintenance levels are defined as follows:

- Maintenance level 1 tools are required for:
 - Sanitary inspection
 - Removal and assembly of pump cover (position 1012) and pump housing (position 1033)
 - Maintenance and exchange of mechanical seals
 - Gear oil filling level adjustment and gear oil exchange
 → *Maintenance level 1 tools must be available on site for proper work conditions.*



- Maintenance level 2 tools are required for:
 - All processes requiring mounting of gear housing (position 2172)
 - Adjustment of spindles (positions 2200 and 2201)
 → *It is highly recommended to have maintenance level 2 tools available on site.*

- Maintenance level 3 tools are required for maintenance of bearing housing
 - *It is not necessary to have maintenance level 3 tools on site. Maintenance level 3 tasks are supposed to be processed in ViscoTec shop.*

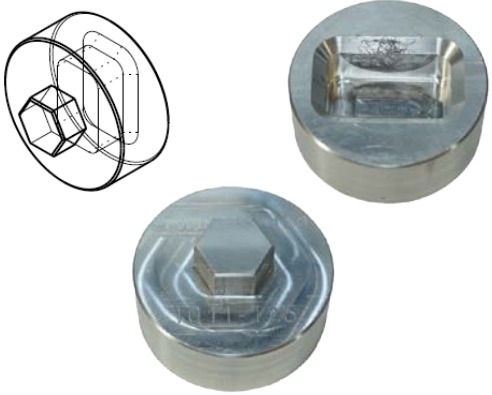

Maintenance level 1 tools

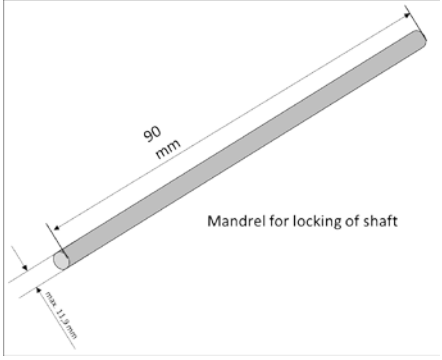

With 1 exception (spindle bolts position 2180), maintenance level 1 only requires standard tools available in public market. Required tools are listed in table below.

Description, Purpose <i>3rd party solution</i>	Tool No. <i>Related position</i>	Maintenance level	eData-ID	Material
Spindle bolt socket 	T-38 (1011-125)	1	12567	Aluminium



Description, Purpose <i>3rd party solution</i>	Tool No. <i>Related position</i>	Maintenance level	eData-ID	Material
<p>Locking rod to block drive shaft</p>  <p>Note: identical rod for all ViscoTwin types</p>	<p>- 1000 / Drive shaft</p>	<p>1</p>	<p>18793</p>	<p>AISI: 304</p>
<p>Torque wrench <u>small</u> for metric sockets to tighten bolts and screws torque controlled</p> <p>Requirements:</p> <ul style="list-style-type: none"> - Min. torque: <= 3.68 lb-ft 5 Nm * - Max. torque: >= min. torque of 'torque wrench 'BIG'' - Compatible with all sockets (hexagon or Allen key) as specified by related positions  <p>Helpful notice:</p> <ol style="list-style-type: none"> 1. *) In case a torque screw driver (see below) is available on site, lowest torque value to handle by means of the <u>small</u> torque wrench is increased accordingly 2. No second wrench is required if whole torque range can be handled by means of 1 torque wrench 	<p>- 2259 1303-BC (Dual Acting Mechanical Seals)</p> <p>2258 , 2186 1008</p>	<p>1 1 2 3</p>	<p>-</p>	<p>-</p>
<p>Torque wrench BIG for metric sockets to tighten bolts and screws torque controlled</p> <p>Requirements:</p> <ul style="list-style-type: none"> - Min. torque: <= maximum torque of 'torque wrench small' - Max. torque: 110.6 lb-ft 150 Nm - Compatible with all sockets (hexagon or Allen key) as specified by related positions 	<p>- 2180, 1016, 1041 2205, 2279, 1526 2177</p>	<p>1 2 2</p>	<p>-</p>	<p>-</p>

Description, Purpose <i>3rd party solution</i>	Tool No. <i>Related position</i>	Maintenance level	eData-ID	Material
Hexagon nut sockets for Bolts M8 Socket size: 13 mm Bolts M16 Socket size: 24 mm Bolts M18 Socket size: 27 mm - Compatible with torque wrench drive 	- 2259 1016 , 1041 2180	1 1 1	-	-

Description, Purpose <i>3rd party solution</i>	Tool No. <i>Related position</i>	Maintenance level	eData-ID	Material
<p><u>For dual acting mechanical seals only:</u> Allen key to tighten hexagon socket screws of outboard rotor holder of double acting mechanical seals.</p> <p>3 different solutions:</p> <p>1. Best practise solution Allen key bit (size 2.5 mm) compatible to torque screw driver:</p>  <p>Allen key bit with hexagon drive</p> <p>2. Good practice solution Allen key socket (size 2.5 mm) compatible to torque screw driver (possibly adaptor required) or small torque wrench (extension and adaptor required)</p>  <p>3. Minimum solution Allen key (size 2.5 mm)</p> 	<p>-</p> <p>1303-BC</p> <p>Anga 6,11,14,15</p>	<p>1</p>	<p>-</p>	<p>-</p>

Description, Purpose <i>3rd party solution</i>	Tool No. <i>Related position</i>	Maintenance level	eData-ID	Material
<p>Various hooks to remove O-rings gently from grooves. Applicable to all ViscoTwin types.</p>  <p><i>3rd party solution:</i> <i>Brand: Craftsman</i> <i>Name: 4PC Hook and Pick Set</i> <i>Item #: 00904981000P</i> <i>Model: 4981</i></p>	<p>- 1303-BF/BC 2261-BF/BC</p>	<p>1 1</p>	<p>-</p>	<p>-</p>
<p>Metric feeler gage to measure clearance between spindles</p> <ul style="list-style-type: none"> - Min. : 0.04 mm - Max.: 0.30 mm or more  <p><i>3rd party solution:</i> <i>Brand: Eastern Industries</i> <i>Type: MFG-25-T-76 GC SERIES</i></p>	<p>- 2200 , 2201</p>	<p>1</p>	<p>-</p>	<p>Steel</p>

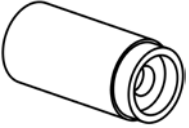
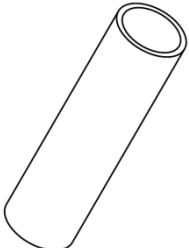

Maintenance level 2 tools

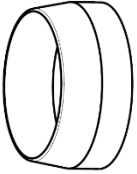
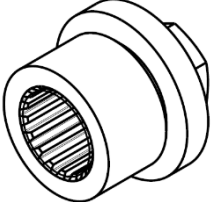
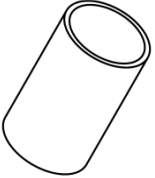
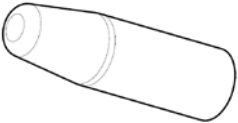

Description, Purpose <i>3rd party solution</i>	Tool No. <i>Related position</i>	Maintenance level	eData-ID	Material
Hexagon sockets drive for Bolts M12 Socket size: 18 mm - Compatible with torque wrench drive 	- 2177	2	-	-
Allen key sockets for Hexagon socket screw M5 Allen key size: 4 mm Hexagon socket screw M8 Allen key size: 6 mm 	- 2186 2258 1008	2 2 3		
Installation pin for bearing crown shaft ring gasket 	T 3 (1011-773)	2	12557	AISI: 304 EN: 1.4301
Installation pipe bearing housing shaft ring gasket 	T 28 (1011-421)	2	12563	Aluminium

Description, Purpose <i>3rd party solution</i>	Tool No. <i>Related position</i>	Maintenance level	eData-ID	Material
Spur gear wheel puller 	T 18 (1009-756)	2	12575	AISI: 304 EN: 1.4301
Shaft ring gasket assembly sleeve bearing housing 	T 26 (1011-083)	2	12570	AISI: 304 EN: 1.4301
Shaft adjustment for keeping the shaft on the gearing 	T 41 (1011-424)	2	12581	AISI: 304 EN: 1.4301
Sliding sleeve for inner race retaining ring needle roller bearing 	T-43 (1011-446)	2	12585	AISI: 304 EN: 1.4301
Mounting sleeve for rotary shaft seal 	T 48 (1011-784)	2	12588	AISI: 304 EN: 1.4301
Mounting device for mounting sealing ring position 1010 (no picture available)	T 77 (SK01-741)	2	18777	AISI: 304 EN: 1.4301

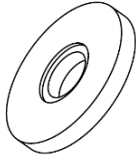
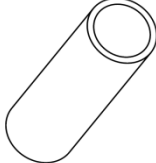
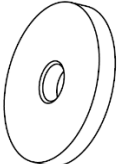
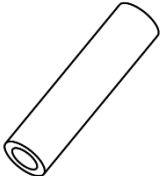
Description, Purpose <i>3rd party solution</i>	Tool No. <i>Related position</i>	Maintenance level	eData-ID	Material
<p>Sealing ring extractor Removal of shaft sealing rings / position 1111</p>  <p><i>Solution:</i> <i>Manufacturer or brand: Kukko</i> <i>Name: Seal pulling set (gasket) in case</i> <i>Part no: K-222-1/7</i></p>	<p>- 1111</p>	<p>2</p>	<p>-</p>	<p>-</p>

Maintenance level 3 tools

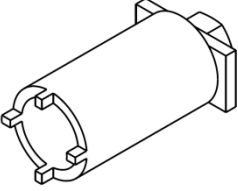
Description, Purpose <i>3rd party solution</i>	Tool No. <i>Related position</i>	Maintenance level	eData-ID	Material
Pressure plate for needle roller bearing inner race 	T 20 (1011-399)	3	12545	AISI: 304 EN: 1.4301
Installation pipe for needle roller bearing outer ring 	T 32 (1011-418)	3	12560	AISI: 304 EN: 1.4301
Receptacle plate installation shaft ball bearing 	T 34 (1011-403)	3	12548	AISI: 304 EN: 1.4301
Installation pipe for ball bearing inner race 	T 22 (1011-408)	3	12551	AISI: 304 EN: 1.4301
Installation pipe for ball bearing outer ring 	T 24 (1011-411)	3	12554	AISI: 304 EN: 1.4301

Description, Purpose <i>3rd party solution</i>	Tool No. <i>Related position</i>	Maintenance level	eData-ID	Material
Socket spanner for groove nut 	T 30 (1011-739)	3	12578	AISI: 304 EN: 1.4301
Installation pipe for inner race retaining ring needle roller bearing 	T 45 (1011-445)	3	18778	AISI: 304 EN: 1.4301

Copyright © Processtec, Inc., Visalia, CA, USA, 2018

Explosion drawing ViscoTwin 130-xx

Einzelteilliste		Parts list		Pièces détachées	
P-No	Qty	Benennung	Description	Description	Description
1000	1	Antriebswelle	Drive shaft	Arbre de commande	
1001	1	Lagergehäuse	Bearing housing	Corps de palier	
1003	2	Nadelnlager	Needle roller bearings	Roulements à aiguilles	
1008	8	Zylinderschraube	Socket head cap screw	Boulon à six pans creux	
1009	4	Sicherungsring	Snap ring	Circlip	
1010	1	Wellendichtring	Shaft sealing ring	Joint d'étanchéité de l'arbre	
1012	1	Deckel	Cover	Couvrir	
1015	4	Scheibe	Washer	Rondelle	
1016	4	Sechskantschraube	Hexagonal screw	Vis à tête hexagonal	
1029	1	Dichtungsgehäuse	Shaft seal housing	Corps de garniture	
1033	1	Pumpengehäuse	Pump housing	Corps de pompe	
1041	4	Sechskantschraube	Hexagonal screw	Vis à tête hexagonal	
1064	2	Gewindestift	Set screw	Vis sans tête	
1088	1	O-Ring	O-ring	O-ring	
1111	2	Wellendichtring	Shaft sealing ring	Joint d'étanchéité de l'arbre	
1121	2	Distanzring	Distance ring	Bague d'écartement	
1183	1	Passfeder	Key	Clavette	
1227	2	Lagerdeckel	Bearing cover	Chapeau de palier	
1303	2	Gleitringdichtung (komplett)	Mechanical seal (Complete)	Garniture mécanique (complet)	
1400	1	Grundplatte	Baseplate	Plateau de base	
1473	1	Antrieb	Drive unit	Entrainement	
1526	1	Wellenmutter	Groove nut	Écrou en T	
1529	2	Distanzhülse	Spacer ring	Manche	
1530	2	Distanzring	Distance ring	Bague d'écartement	
1538	1	Typenschild	Type plate	Plaque signalétique	
1541	1	Ölstandsaug	Oil level glass	Voyant de niveau d'huile	
1543	1	Getriebeöl	Gear oil	Huile à engrenages	
1570	1	Federring	Spring ring	Circlip	
2171	1	Abtriebswelle	Driven shaft	Arbre de sortie	
2172	1	Getriebegehäuse	Gear housing	Logement d'entraînement	
2174	4	Fundamentblock	Foundation bloc	Fondation bloc	
2176	1	Nabe	Driving collar	Moyeu	
2177	1	Sechskantschraube	Hexagonal screw	Vis à tête hexagonal	
2178	1	Spannscheibe	Lock washer	Plaque de serrage	
2179	2	Passfeder	Key	Clavette	
2180	2	Spindelmutter	Nut for spindle	Écrou pour le fuseau	
2181	8	Schräggelager	Angular ball bearing	Roulements à billes à contact oblique	
2183	1	Stirnrad Antrieb	Spur gear, drifty	Engrenage, flottante	

Einzelteilliste		Parts list		Pièces détachées	
P-No	Qty	Benennung	Description	Description	Description
2184	1	Stirnrad Antrieb	Spur gear, propellied	Engrenage, actionnée	
2186	8	Zylinderschraube	Socket head cap screw	Boulon à six pans creux	
2187	8	Scheibe	Washer	Rondelle	
2192	1	O-Ring	O-ring	O-ring	
2194	2	O-Ring	O-ring	O-ring	
2195	2	Passstift	Dowel pin	Goupille de serrage	
2196	2	Passstift	Dowel pin	Goupille de serrage	
2198	1	Flachdichtung	Flat seal	Joint	
2200	1	Schraubenspindel, linksgängig	Screw spindle, left handed	Vérin, fileté à gauche	
2201	1	Schraubenspindel, rechtsgängig	Screw spindle, right handed	Vérin, fileté à droite	
2204	1	Kupplungsschutz (komplett)	Coupling guard (complete)	Garde de couplage (complet)	
2205	4	Sechskantschraube	Hexagonal screw	Vis à tête hexagonal	
2232	1	Entlüftungsschraube / Quench	Breather plug / Quench	Bouchon évent / Quench	
2233	2	Verschlusschraube	Plug screw	Vis d'arrêt	
2246	4	Sechskantschraube	Hexagonal screw	Vis à tête hexagonal	
2247	1	Kupplungsteil, Pumpe	Clutch part, pump	Élément d'accouplement, pompe	
2248	1	Kupplungsteil, Antrieb	Clutch part, drive	Élément d'accouplement, Entraîner	
2249	1	Zahnkranz	Sprocket	Pignon	
2250	2	Laternenschutz	Lantern protection	Protection de la lanterne	
2251	2	Sechskantschraube	Hexagonal screw	Vis à tête hexagonal	
2252	4	Scheibe	Washer	Rondelle	
2253	2	Sechskantmutter	Hexagonal nut	Écrou hexagonal	
2256	2	Passstift	Dowel pin	Goupille de serrage	
2258	8	Zylinderschraube	Socket head cap screw	Boulon à six pans creux	
2261	1	O - Ring Dichtungssatz	O-ring seal kit	Joint kit	
2265	4	Kontaktschutz Pumpe	Contact protection pump	protecteur de contact pompe	
2266	4	Kontaktschutz Motor	Contact protection motor	protecteur de contact moteur	
2272	2	Wellendichtring	Shaft sealing ring	Joint d'étanchéité de l'arbre	
2273	2	Wellenschonhülse	Shaft sleeve	Chemise d'arbre	
2274	2	Schleuderscheibe	Centrifugal disk	Rondelle de joint	
2277	4	Kontaktschutz Lagergehäuse	Contact protection bearing housing	protecteur de contact corps de palier	
2278*	4	Fundamentblock	Foundation bloc	Fondation bloc	
2279	4	Sechskantschraube	Hexagonal screw	Vis à tête hexagonal	
2280*	4	Sechskantschraube	Hexagonal screw	Vis à tête hexagonal	

*if necessary

*wenn erforderlich

The Engineering Design and Technical Construction File

4. CIP - SIP and COP Instructions, Swab-Testing Instructions

4.1 CIP & SIP Instructions

Pumps in a processing system by 3A Standard (02-11)

Pumps used in a SIP processing system must be equipped with a pressure monitoring device, which shuts down the system immediately if the processed product falls below atmospheric pressure and the system cannot be re-started without getting sterilized again.

4.1.1 C.I.P. – process

Are suitable for the materials of the pump:

Use 1 percent nitric acid solution at a temperature up to 82 ° C (acid)

or use a 1 percent solution of sodium hydroxide or sodium hypochlorite (200ppm) (alkaline) for your C.I.P. process.

For pump housings with chrome-wear coating pH values below 3 are not permitted. Therefore use an accordingly lower acid concentration when using the nitric acid solution for CIP Cleaning.

4.1.2 S.I.P – process

Are suitable for the materials of the pump:

Sterilization over a period from 10 to 30 minutes with saturated steam at about 2.2 bars is allowed.

The maximum steam temperature for elastomeric materials in EPDM is 121° C.

The maximum steam temperature for elastomeric materials in FKM is 135° C.

If the equipment is installed in an aseptic processing system that is sterilized by heat and operated At a temperature of 250°F (121°C) or higher, 3-A Standard 02-11 requires that the system monitors Internal pressure and shuts the system automatically down if the product pressure in the system Becomes less that atmospheric. The system shall only be able to be restarted after it is re-sterilized.



Warning!

Risk of injuries through rotating machine parts or from liquids escaping under pressure.

Potential consequences: Severe or fatal injuries.

4.1.3 Do not perform any work with the pump running!

Disconnect the pump from mains and secure against inadvertent start up. (U-lock)

Use safety gloves and goggles when using aggressive detergents.

4.1.3.1 Connect pump to CIP cleaning system or switch system.

4.1.3.2 Start cleaning system.

4.1.3.3 Cleaning pipe line system and pump.

4.1.3.4 Shut cleaning system, remove CIP medium completely.



C.I.P. cleaning must conform to the hygiene of foodstuffs regulations as amended from time to time. The specifics pertaining to material stability must be strictly observed.

In case you have developed own C.I.P. cleaning methods for your pumping media, ensure pump suitability for the selected method by consulting the pump supplier.

ATTENTION

Possible damage to property

Avoid abrupt changes in temperature during cleaning process with the pump in stationary state, fill in hot medium and wait until the pump has warmed up..

4.2 Inspection of sanitary pumps for food processing.

The instruction given in chapter 7.2 'Notes on service and maintenance' apply exceedingly to sanitary pumps for food processing.

Then the spindle screws are to be checked every 100 operating hours. If contamination (underneath the O-ring) is detected, all parts in this sector which are in direct contact with the medium (spindle, spindle screw with O-ring) must be dismantled and thoroughly cleaned in an alcoholic bath. Clean and disinfect the shafts and all inner parts of the pump housing carefully with alcohol solution and a clean cloth. Renew the O-ring of the spindle screw 2194 and the O-ring 130 of the Inboard Rotor Holder 80 inside the mechanical seal. (® _see Parts List)

Subsequently, no corrosion or seizure marks must be visible; otherwise the affected parts must be replaced.

If contamination on the mechanical seal outside the medium sector is detected after 500 cleaning cycles or one year at the latest, all component parts of the mechanical seal are to be thoroughly cleaned and disinfected in an alcohol bath. Replace all O-rings of the Inboard Rotor Holder (O-ring 90, 130, 140 and 220). (® _see Parts List)

Subsequently, no corrosion or seizure marks must be visible; otherwise the affected parts must be replaced.

1. Remove Bolts from the Spindles and first visually test the cleanliness of the O-ring and the groove.
2. Visually check cleanliness of threads on the shaft

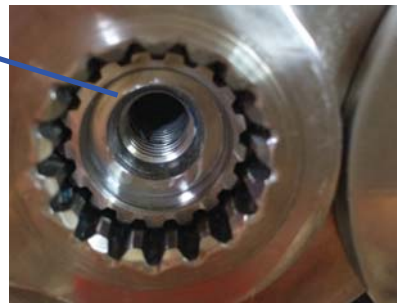

3. Remove O-Rings and clean bolts with FDA-compliant detergent. If needed sanitize with alcohol-bath
4. Remove residue from bolts with the use of a sturdy brush
5. Remove residue from the threads by spraying alcohol, blow it out with compressed air
- hold a towel in front of the thread to protect yourself from spilling solution.
6. Wipe it with non-fuzzing paper towel dry and clean.
7. Now install NEW O-rings (3-A approved elastomers) and fixate with medium strength Loctite food grade, torqued to required value. (see Appendix "Torque-table")

Fully drainable pump housing due to machined DRAIN in the front cover. See picture below:

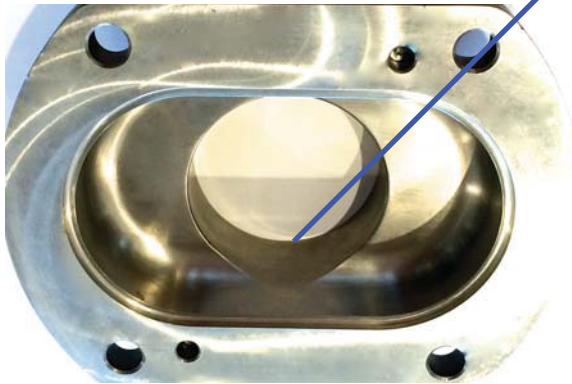

Make sure, drain shows to bottom when Mounting to the housing

4.3 COP (manual cleaning) Instructions

4.3.1 **Safety is first – DISCONNECT THE PUMP FROM THE POWER!**

4.3.2 Disconnect piping from the pump housing

4.3.3 Remove the 4 hexagon screws (Pos. 1016 on explosion drawing)

4.3.4 Remove the pump housing and manually wash it properly with FDA-compliant detergent. Avoid scratching pads. Rinse it with clear water.

4.3.5 Clean the impellers manually with non-scratching pad or sponge with FDA-compliant detergent. Spin the shafts to clean the impellers from all sides. Rinse with clear water.

4.4 Swab-Test

4.4.1 **Safety is first – DISCONNECT THE PUMP FROM THE POWER!**

4.4.2 Disconnect piping from pump housing

4.4.3 Remove the 4 hexagon screws (Pos. 1016 on explosion drawing)

4.4.4 Remove pump housing carefully

4.4.5 Take swab-sample as per Lab-Instruction of food-safety instructions (This procedure may be vary based on customer's internal requirements)

4.5 Switching on

Check before switching on:

4.5.1 **Pump with drive safely installed and connected?**

4.5.2 **Connections sealing and connected stress-free?**

4.5.3 **Oil level checked?**

- 4.5.4 Quench fluid level OK?
- 4.5.5 Correct pressure set in case of a counter-pressure device?
- 4.5.6 Rotational direction checked?

- 4.5.7 Safety devices (covers and limit switches, safety valve) installed and checked for function?
 - 4.5.7.1 Before start up, check pump for contamination and foreign objects.
 - 4.5.7.2 Fully open pressure and suction-side valves.
 - 4.5.7.3 Fill pump with medium to enable suction safely.
 - 4.5.7.4 Switch on drive.

4.6 When initially operating the pump, check to see whether it and the pipe lines are tight.

Operation

	Warning!
	Do not operate against closed shut-off devices. Bursting of the pipe line or downstream system components is possible. Potential consequences: Severe or fatal injuries.
Secure the pump through an approved overpressure protection.	
ATTENTION	Possible damage to property

The Engineering Design and Technical Construction File

12. Gear Oil – maintenance

12.1 Gear-Oil Type

Use only designated food – grade gear lubricant, such as:

- Castrol Optileb Hy 68
- AVIA AVIAFOOD GEAR 220
- Mobil Mobil DTE FM 220

12.2 Fill-Level

Please take manual page 22 fig. 7-1 Oil-level gauge for reference.

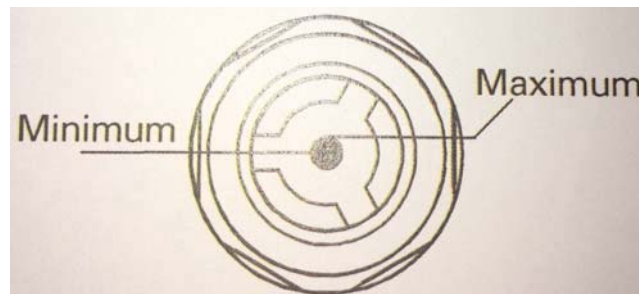

Fig. 7-1 Oil-level gauge

12.3 First Oil Change:

First Oil Change is due after 250 hours of operation

12.4 Check Oil Level:

Check Oil level at least weekly and top level up if necessary to Maximum level

As per fig. 7-1 under point 12.2

(turn pump off, wait 3 min. to cool down the oil to show the actual level in the sight glass of the level gauge)

12.5 Oil changes

Oil changes have to take place every 3000 hours of operation

In case the oil shows color-changes, oil has to be changed immediately and the change rhythm has to be adjusted based on the need through excessive use of the pump.

General recommendation: Please put the recommended maintenance routine of the Manual on page 21 to set up a service-routine for your ViscoTwin.

Your Pump will show its great performance for a longer time on a high level.

Tightening torque values ViscoTwin 130

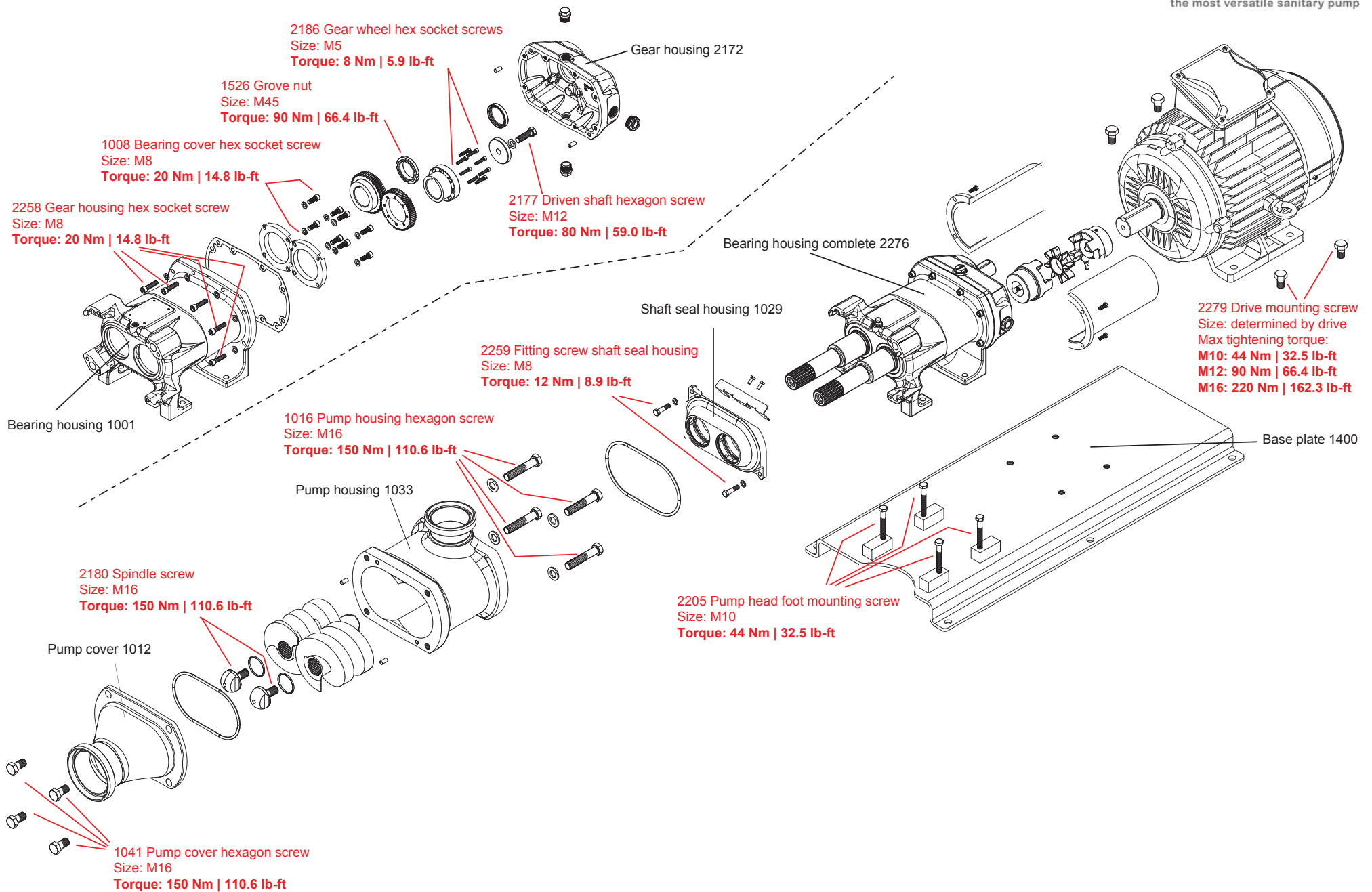

Data sheet

Type: ViscoTwin 130-44 3A Ready to upgrade to high pressure 30 bar
 Serial no: P944769.C1607251102

Specification

Customer:	Kraft Foods MN, New Ulm MN, USA
-----------	---------------------------------

Pump identification

Pump type:	ViscoTwin 130-44 Ready to upgrade to HP	EDATA component-ID:	18338
Serial-#:	P944769.C1607251102		
MPN (Configuration):	130BCI2B1/D3F/OD4"TCOD4"TC/44VRT3/H0S03A-L40135CIN012.18CI-BAN630hpCIPX0FXFCX-B130SSN32X-A		

Pump head

EDATA4U component ID	18327
MPN	130BCI2B1/D3F/OD4"TCOD4"TC/44VRT3/H0S03A
Type	130-44 3A Ready to Upgrade to HP
Screw type screw pitch	130-44 44 mm
Screw material	Stainless: AISI: 316L (EN: 1.4404)
Screw hardened	Yes
Screw arrangement	V
Rotation (viewed from motor)	R (Clockwise)
Pump housing port orientation	Top
Pin configuration	3
Shaft sealing type	Dual Acting Mechanical Seals
Shaft sealing materials	SIC/SIC/FKM//CrO/C/FKM
Flushing of mechanical seal	Required
Pump housing material	Stainless: AISI: 316L (EN: 1.4404)
Process connection pump housing	Tri clamp OD4"
Process connection front port	Tri clamp OD4"
Suction port	Pump cover port
Discharge port	Pump housing top port
Elastomer	FKM
Material drive shaft	Stainless: AISI: 316L (EN: 1.4404)
Drive shaft diameter	35 mm
Atex-execution	No
Temperature probe	Without
Gear oil cooling	Without
Special accessories	No
Quench fluid vessel	Without
Heating jacket	Without





ViscoTwin 130-44

Table of content

Data Sheets

Motor information

Gear oil procurement

Spare parts list

Spare parts explosion drawing

Manual (detailed table of content see manual)

- 1 Safety notes
- 2 Construction and general description
- 3 Transport, packaging, storage
- 4 Assembly / installation
- 5 Commissioning
- 6 Placing out of operation
- 7 Maintenance and servicing
- 8 Disturbances and their elimination
- 9 Disassembly and assembly
- 10 Stocking of spare parts

Appendix

- Tools required for maintenance and servicing
- Explosion drawings with index
- The Engineering Design and Technical Construction File
 - CIP | SIP | Manual Cleaning
 - Oil change
- Tightening torque values

All rights, also reproduction in the form of extracts thereof reserved.
All information is supplied without any liability.