

SPARE PARTS

Frame #4

F4

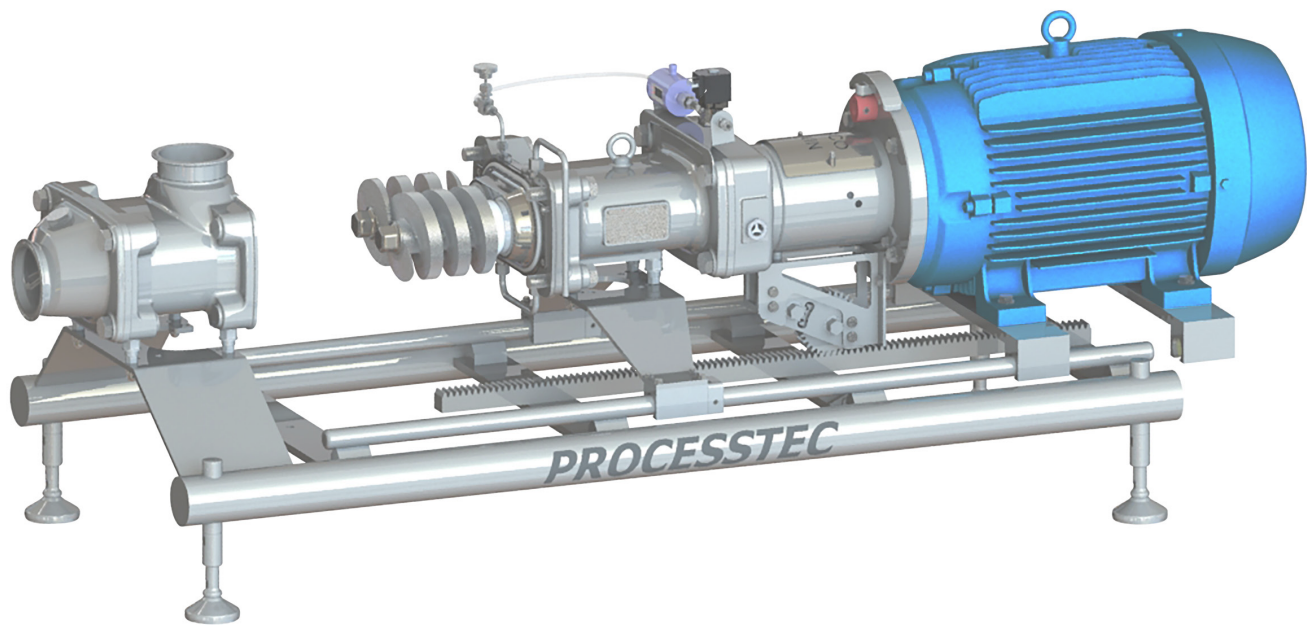

GET TOMORROW'S TECHNOLOGY TODAY

processtec.com
info@processtec.com

9938 W Legacy Ave
Visalia, CA 93291
Phone +1 (559) 429 - 4227
Fax +1 (559) 429 - 4228

1. OVERVIEW: Frame #4 **3**

2. EXPLOSION DRAWING: Frame #4 **4**

3. SPARE PARTS: Frame #4..... **5**

1. OVERVIEW: Frame #4

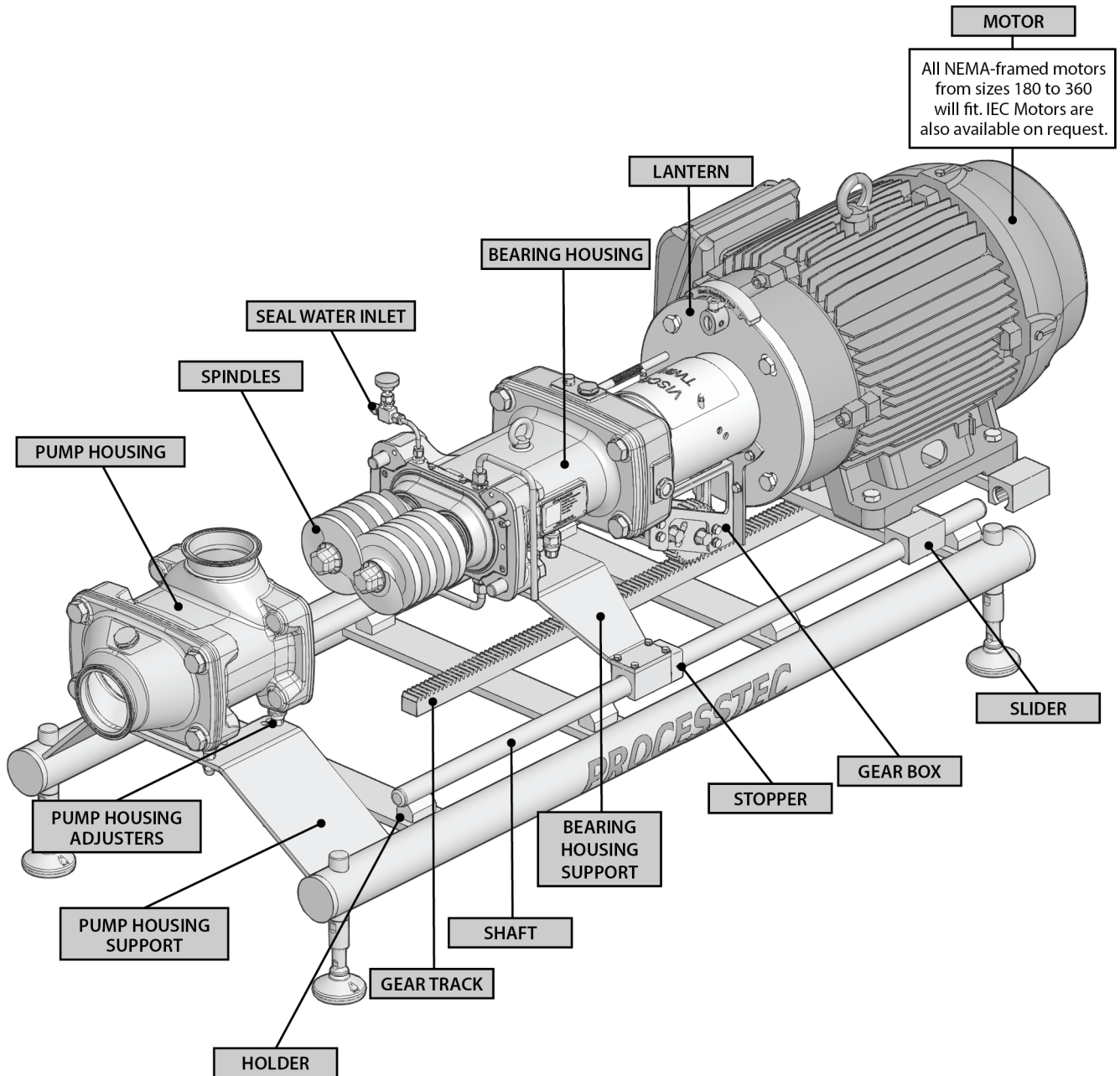

2. EXPLOSION DRAWING: Frame #4

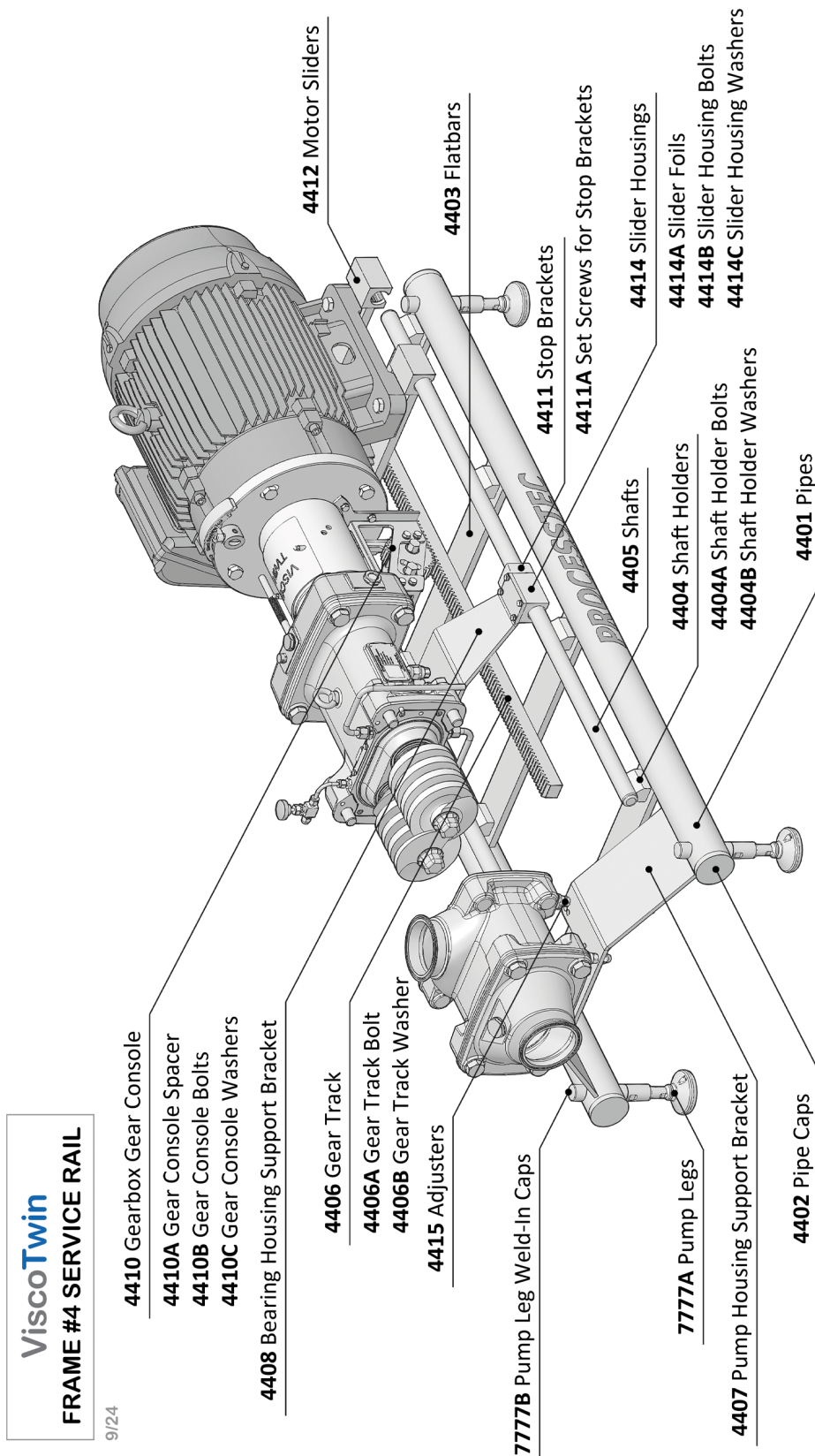



3. SPARE PARTS: Frame #4

FRAME #4	F4 Shaft Holder	POS. 4404
PART #	22208	
CUSTOMER REFERENCE #		
MATERIAL	316	
SPECS	--	
NOTES	--	

FRAME #4	F4 Shaft Holder Bolt M10x1.5x55mm	POS. 4404 A
PART #	23395	
CUSTOMER REFERENCE #		
MATERIAL	316	
SPECS	M10 x 1.5 x 55mm	
NOTES	--	

FRAME #4	F4 Shaft Holder Washer M10x30	POS. 4404 B
PART #	23396	
CUSTOMER REFERENCE #		
MATERIAL	SS	
SPECS	M10 x 30mm	
NOTES	--	

FRAME #4	F4 Gear Track Bolt M10x1.5x30mm	POS. 4406 A
PART #	18840	
CUSTOMER REFERENCE #		
MATERIAL	316	
SPECS	10mm	
NOTES	--	

FRAME #4	F4 Gear Track Washer M10	POS. 4406 B
PART #	19026	
CUSTOMER REFERENCE #		
MATERIAL	316	
SPECS	--	
NOTES	--	

FRAME #4	F4 Stop Bracket	POS. 4411
PART #	22217	
CUSTOMER REFERENCE #		
MATERIAL	304	
SPECS	--	
NOTES	--	

FRAME #4	F4 Stopbracket Setscrew	POS. 4411 A
PART #	23484	
CUSTOMER REFERENCE #		
MATERIAL	SS	
SPECS	M5 - 0.8 x 5, with key 2.5mm head socket	
NOTES	--	

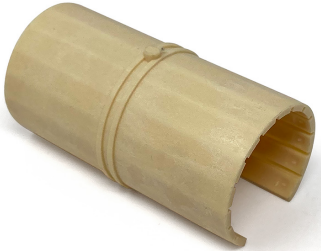
FRAME #4	F4 Slider Foil	POS. 4414 A
PART #	22244	
CUSTOMER REFERENCE #		
MATERIAL	IGD	
SPECS	--	
NOTES	--	

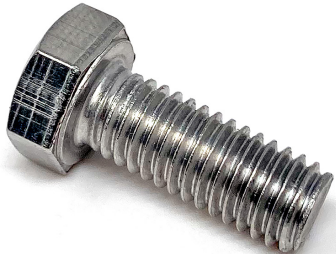
FRAME #4	F4 Slider Housing Bolt M6x1.0x20mm	POS. 4414 B
PART #	22242	
CUSTOMER REFERENCE #		
MATERIAL	316	
SPECS	6mm	
NOTES	--	

FRAME #4	Gear Console Washer M6	POS. 4414 C
PART #	20319	
CUSTOMER REFERENCE #		
MATERIAL	316	
SPECS	--	
NOTES	--	

FRAME #4	F4 Adjuster G2	POS. 4415
PART #	23480	
CUSTOMER REFERENCE #		
MATERIAL	304	
SPECS	6mm/10mm	
NOTES	--	

FRAME #4	F4 Pump Leg Short	POS. 7777 A
PART #	22732	
CUSTOMER REFERENCE #		
MATERIAL	304	
SPECS	Thread Size M20 - 2.5	
NOTES	--	

FRAME #4	F4 Pump Leg Medium	POS. 7777 A
PART #	21557	
CUSTOMER REFERENCE #		
MATERIAL	304	
SPECS	Thread Size M20 - 2.5	
NOTES	--	

FRAME #4	F4 Pump Leg Long	POS. 7777 A
PART #	21769	
CUSTOMER REFERENCE #		
MATERIAL	304	
SPECS	Thread Size M20 - 2.5	
NOTES	--	

FRAME #4	F4 Pump Leg XL	POS. 7777 A
PART #	23499	
CUSTOMER REFERENCE #		
MATERIAL	304	
SPECS	Thread Size M20 - 2.5	
NOTES	--	

FRAME #4	F4 Pump Leg XXL	POS. 7777 A
PART #	23500	
CUSTOMER REFERENCE #		
MATERIAL	304	
SPECS	Thread Size M20 - 2.5	
NOTES	--	