

# SPARE PARTS

ViscoTwin

# VT130

G7

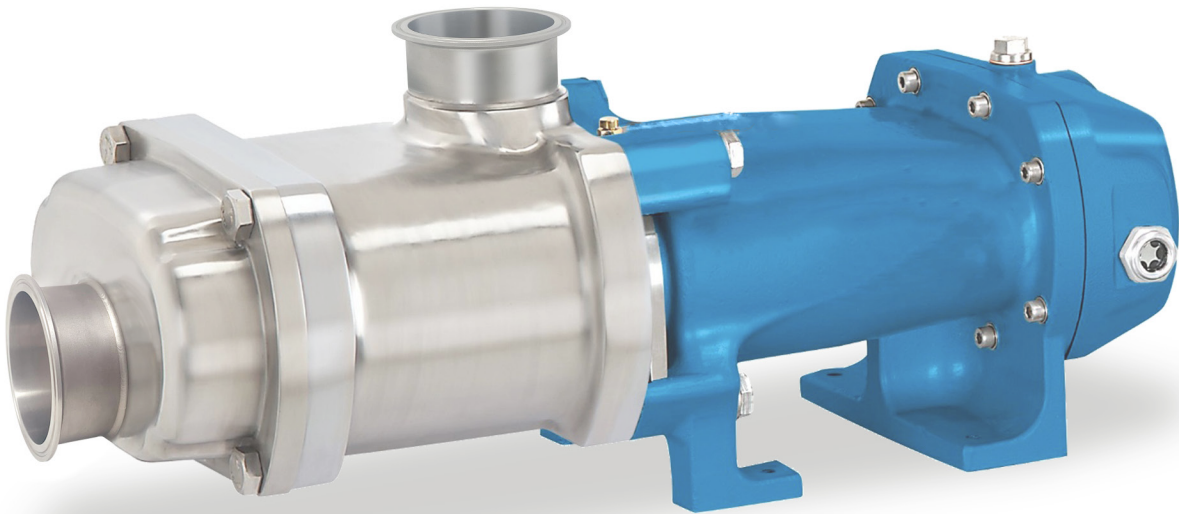

 **PROCESSTEC**  
GET TOMORROW'S TECHNOLOGY TODAY

[processtec.com](http://processtec.com)  
[info@processtec.com](mailto:info@processtec.com)

9938 W Legacy Ave  
Visalia, CA 93291  
Phone +1 (559) 429 - 4227  
Fax +1 (559) 429 - 4228

**1. OVERVIEW DRAWING . . . . . 3**

**2. EXPLOSION DRAWING . . . . . 4**

**3. TORQUE VALUES. . . . . 5**

**4. SPARE PARTS. . . . . 6**

**4.1 Pump Housing. . . . . 6**

**4.2 Seal Housing . . . . . 13**

**4.3 Bearing Housing . . . . . 23**

**4.4 Gear Housing. . . . . 31**

**4.5 Drive Train. . . . . 40**

**1. OVERVIEW DRAWING**

**Industrial Mounting**

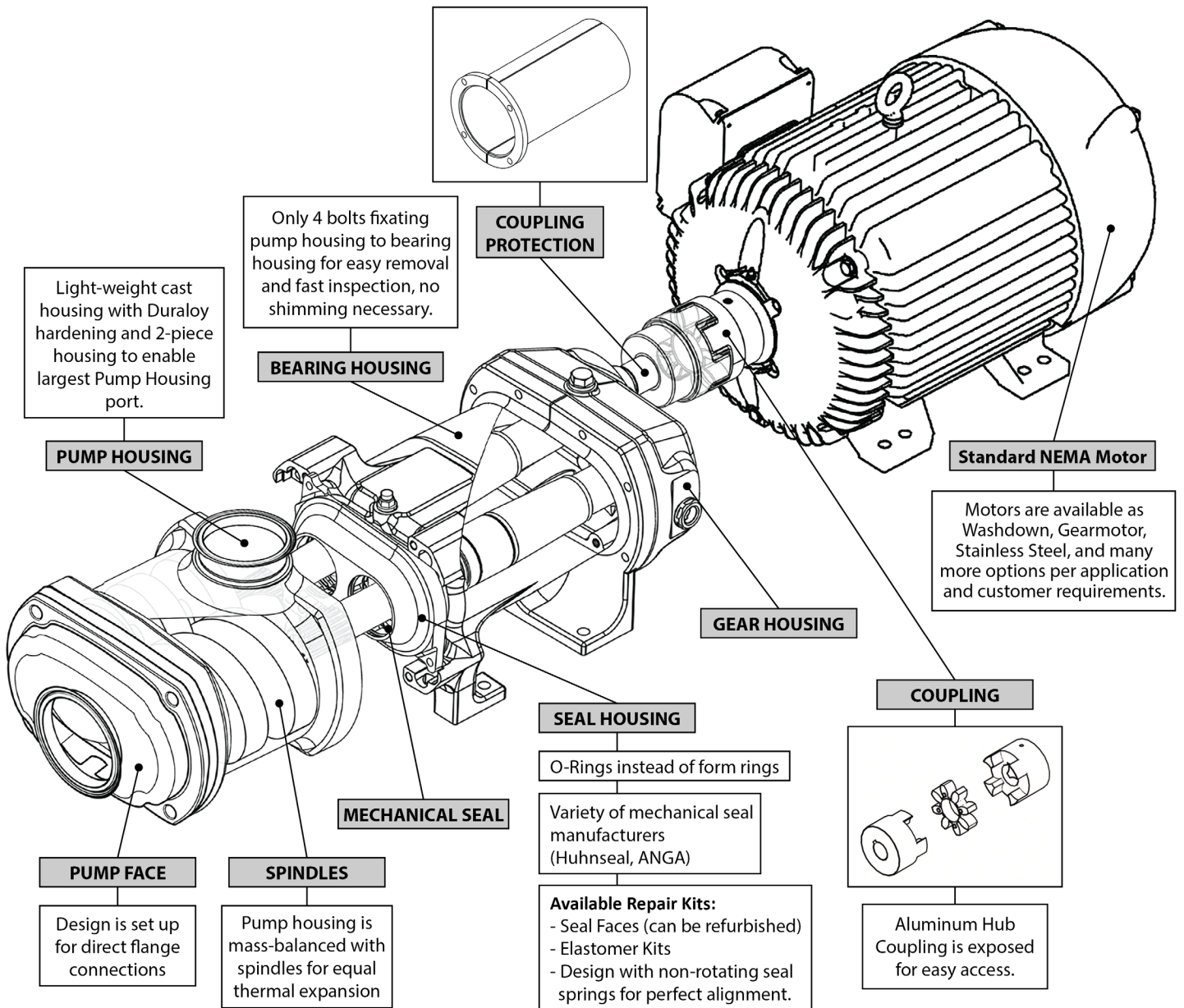

**2. EXPLOSION DRAWING**

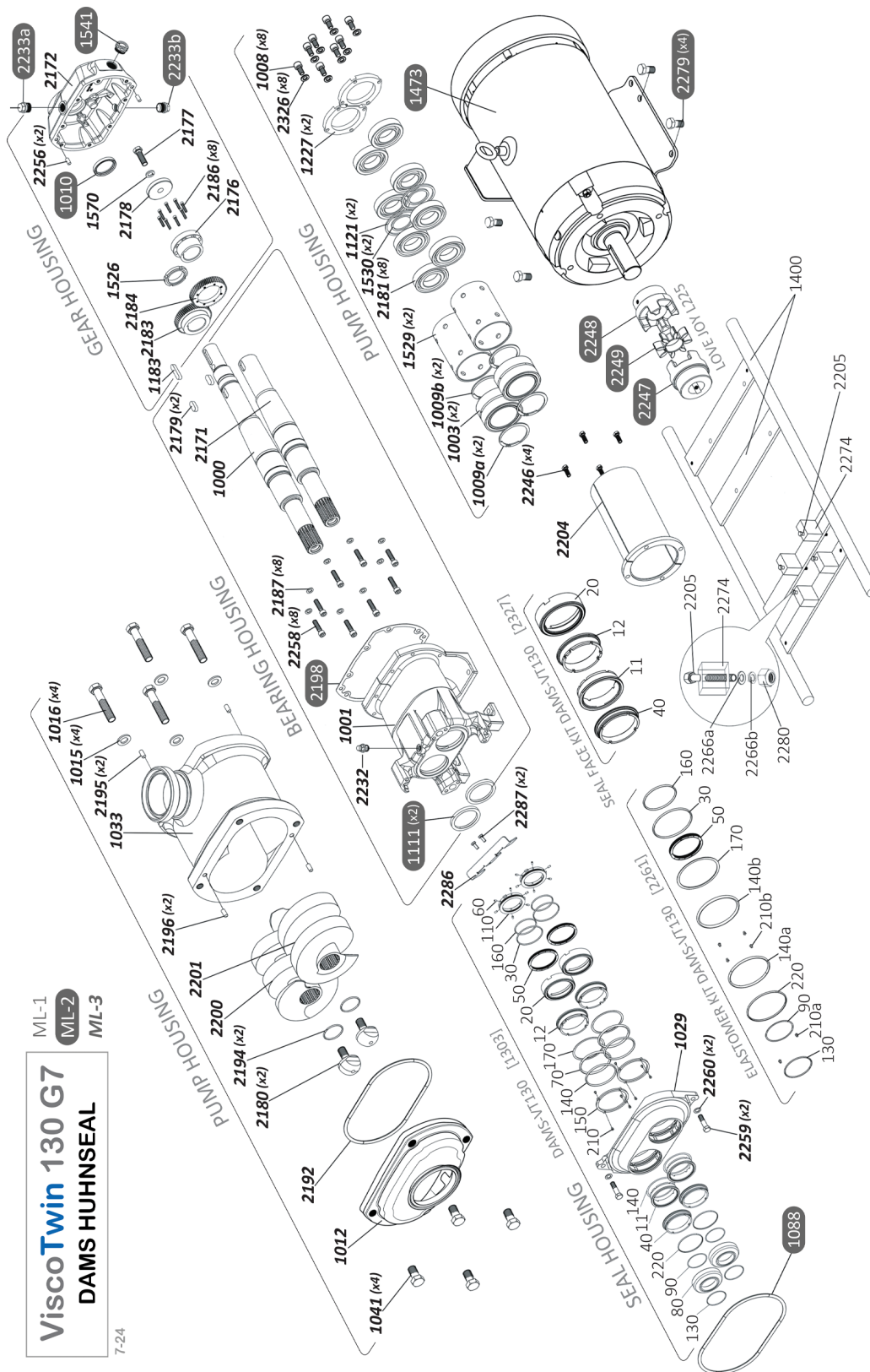

7-24

**ViscoTwin 130 G7**  
**DAMS HUHNSEAL**

ML-1  
ML-2  
ML-3



**3. TORQUE VALUES**

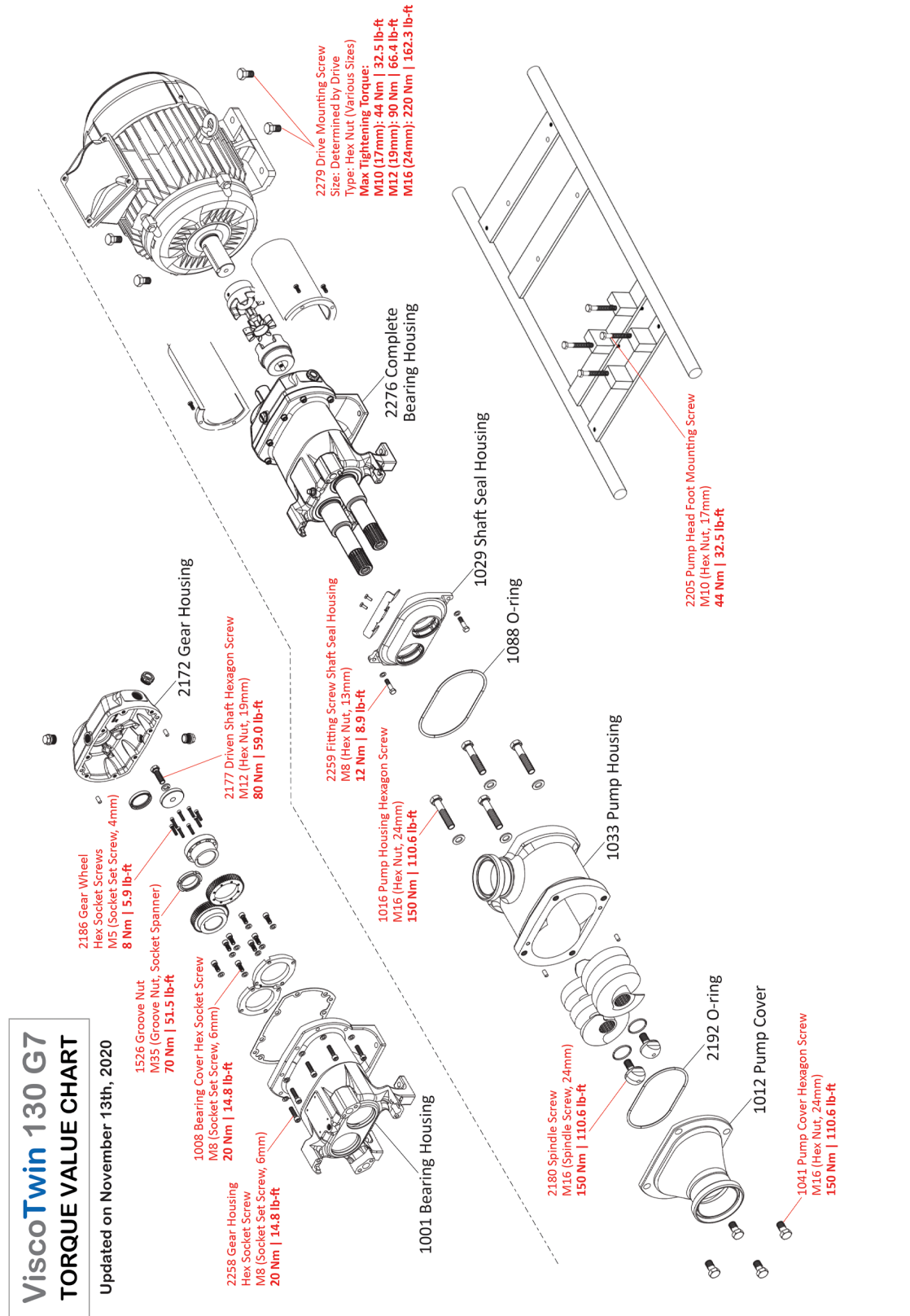

**ViscoTwin 130 G7**  
**TORQUE VALUE CHART**

Updated on November 13th, 2020





## 4. SPARE PARTS

### 4.1 Pump Housing

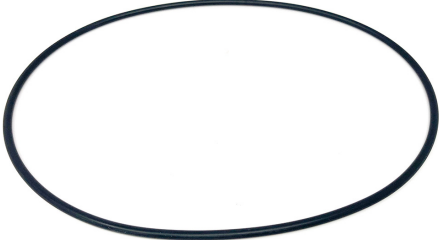
<b>VT130 G7</b>	<b>Spindle Bolt</b>	<b>POS. 2180</b>
<b>PART #</b>	<b>23113</b>	
<b>CUSTOMER REFERENCE #</b>		
<b>MATERIAL</b>	2205	
<b>SPECS</b>	Hex Style	
<b>NOTES</b>	--	

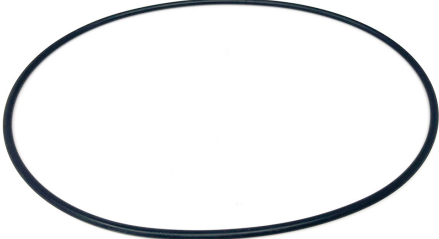
<b>VT130 G7</b>	<b>O-Ring for Pump Face</b>	<b>POS. 2192</b>
<b>PART #</b>	<b>12516</b>	
<b>CUSTOMER REFERENCE #</b>		
<b>MATERIAL</b>	FKM	
<b>SPECS</b>	186.5 x 4mm	
<b>NOTES</b>	--	

<b>VT130 G7</b>	<b>O-Ring for Pump Face</b>	<b>POS. 2192</b>
<b>PART #</b>	<b>12520</b>	
<b>CUSTOMER REFERENCE #</b>		
<b>MATERIAL</b>	EPDM	
<b>SPECS</b>	186.5 x 4mm	
<b>NOTES</b>	--	

<b>VT130 G7</b>	<b>O-Ring for Spindle Bolt</b>	<b>POS. 2194</b>
<b>PART #</b>	<b>12504</b>	
<b>CUSTOMER REFERENCE #</b>		
<b>MATERIAL</b>	FKM	
<b>SPECS</b>	42 x 3mm	
<b>NOTES</b>	--	

<b>VT130 G7</b>	<b>O-Ring for Spindle Bolt</b>	<b>POS. 2194</b>
<b>PART #</b>	<b>12510</b>	
<b>CUSTOMER REFERENCE #</b>		
<b>MATERIAL</b>	EPDM	
<b>SPECS</b>	42 x 3mm	
<b>NOTES</b>	--	

<b>VT130 G7</b>	<b>Dowel Pin for Pump Face &amp; Housing</b>	<b>POS. 2195, 2196</b>
<b>PART #</b>	<b>8385</b>	
<b>CUSTOMER REFERENCE #</b>		
<b>MATERIAL</b>	316L	
<b>SPECS</b>	8mm/16mm	
<b>NOTES</b>	--	



<b>VT130 G7</b>	<b>Spindle Pair VT130.33</b>	<b>POS. 2202</b>
<b>PART #</b>	<b>21777</b>	
<b>CUSTOMER REFERENCE #</b>		
<b>MATERIAL</b>	316L	
<b>SPECS</b>	33mm, hardened	
<b>NOTES</b>		

<b>VT130 G7</b>	<b>Spindle Pair VT130.44</b>	<b>POS. 2202</b>
<b>PART #</b>	<b>14260</b>	
<b>CUSTOMER REFERENCE #</b>		
<b>MATERIAL</b>	316L	
<b>SPECS</b>	44mm, hardened	
<b>NOTES</b>		

<b>VT130 G7</b>	<b>Spindle Pair VT130.65</b>	<b>POS. 2202</b>
<b>PART #</b>	<b>23618</b>	
<b>CUSTOMER REFERENCE #</b>		
<b>MATERIAL</b>	316L	
<b>SPECS</b>	65mm, hardened	
<b>NOTES</b>		

<b>VT130 G7</b>	<b>Pump Face OD3"</b>	<b>POS. 1012</b>
<b>PART #</b>	<b>20214</b>	
<b>CUSTOMER REFERENCE #</b>		
<b>MATERIAL</b>	316Ti	
<b>SPECS</b>	PF:OD3" Tri-Clamp	
<b>NOTES</b>	--	

<b>VT130 G7</b>	<b>Pump Face OD4"</b>	<b>POS. 1012</b>
<b>PART #</b>	<b>19145</b>	
<b>CUSTOMER REFERENCE #</b>		
<b>MATERIAL</b>	316Ti	
<b>SPECS</b>	PF:OD4", Tri-Clamp	
<b>NOTES</b>	--	

<b>VT130 G7</b>	<b>Hex Head Cap Screw for Pump Face</b>	<b>POS. 1041</b>
<b>PART #</b>	<b>19358</b>	
<b>CUSTOMER REFERENCE #</b>		
<b>MATERIAL</b>	A270	
<b>SPECS</b>	ISO4017 - M16 x 30mm	
<b>NOTES</b>	--	

<b>VT130 G7</b>	<b>Pump Housing OD3"</b>	<b>POS. 1033</b>
<b>PART #</b>	<b>19010</b>	
<b>CUSTOMER REFERENCE #</b>		
<b>MATERIAL</b>	316L	
<b>SPECS</b>	PCP:OD3"	
<b>NOTES</b>	--	

<b>VT130 G7</b>	<b>Pump Housing OD4"</b>	<b>POS. 1033</b>
<b>PART #</b>	<b>19006</b>	
<b>CUSTOMER REFERENCE #</b>		
<b>MATERIAL</b>	316L	
<b>SPECS</b>	PCP:OD4"	
<b>NOTES</b>	--	

**4.2 Seal Housing**

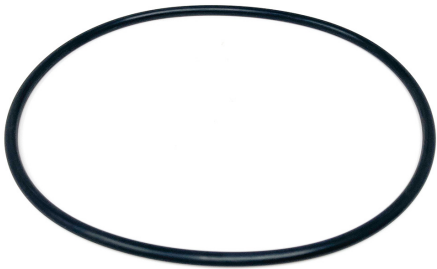
<b>VT130 G7</b>	<b>O-Ring Seal Housing</b>	<b>POS. 1088</b>
<b>PART #</b>	<b>12515</b>	
<b>CUSTOMER REFERENCE #</b>		
<b>MATERIAL</b>	FKM	
<b>SPECS</b>	180 x 6mm	
<b>NOTES</b>	--	

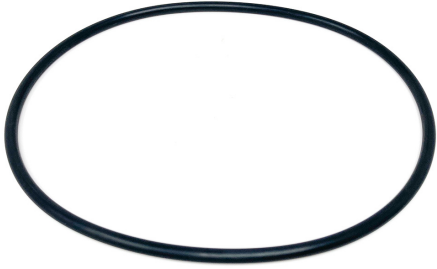
<b>VT130 G7</b>	<b>O-Ring Seal Housing</b>	<b>POS. 1088</b>
<b>PART #</b>	<b>12519</b>	
<b>CUSTOMER REFERENCE #</b>		
<b>MATERIAL</b>	EPDM	
<b>SPECS</b>	180 x 6mm	
<b>NOTES</b>	--	

<b>VT130 G7</b>	<b>Elastomer Kit SAMS</b>	<b>POS. 2261 BF</b>
<b>PART #</b>	<b>12517</b>	
<b>CUSTOMER REFERENCE #</b>		
<b>MATERIAL</b>	FKM	
<b>SPECS</b>	HUHNSEAL, SD: 55mm	
<b>NOTES</b>	--	

<b>VT130 G7</b>	<b>Elastomer Kit SAMS</b>	<b>POS. 2261 BF</b>
<b>PART #</b>	<b>12518</b>	
<b>CUSTOMER REFERENCE #</b>		
<b>MATERIAL</b>	EPDM	
<b>SPECS</b>	HUHNSEAL, SD: 55mm	
<b>NOTES</b>	--	

<b>VT130 G7</b>	<b>Elastomer Kit DAMS</b>	<b>POS. 2261 BC</b>
<b>PART #</b>	<b>18447</b>	
<b>CUSTOMER REFERENCE #</b>		
<b>MATERIAL</b>	FKM	
<b>SPECS</b>	HUHNSEAL, SD: 55mm	
<b>NOTES</b>	--	

<b>VT130 G7</b>	<b>Elastomer Kit DAMS</b>	<b>POS. 2261 BC</b>
<b>PART #</b>	<b>18448</b>	
<b>CUSTOMER REFERENCE #</b>		
<b>MATERIAL</b>	EPDM	
<b>SPECS</b>	HUHNSEAL, SD: 55mm	
<b>NOTES</b>	--	

<b>VT130 G7</b>	<b>Mechanical Seal SAMS</b>	<b>POS. 1303 BF</b>
<b>PART #</b>	<b>11750</b>	
<b>CUSTOMER REFERENCE #</b>		
<b>MATERIAL</b>	316Ti/SiC, FKM	
<b>SPECS</b>	HUHNSEAL, SD: 55mm	
<b>NOTES</b>	--	

<b>VT130 G7</b>	<b>Mechanical Seal SAMS</b>	<b>POS. 1303 BF</b>
<b>PART #</b>	<b>5656</b>	
<b>CUSTOMER REFERENCE #</b>		
<b>MATERIAL</b>	316Ti/SiC, EPDM	
<b>SPECS</b>	HUHNSEAL, SD: 55mm	
<b>NOTES</b>	--	





<b>VT130 G7</b>	<b>Mechanical Seal SAMS</b>	<b>POS. 1303 BF</b>
<b>PART #</b>	<b>11459</b>	
<b>CUSTOMER REFERENCE #</b>		
<b>MATERIAL</b>	316Ti/TuCKE, FKM	
<b>SPECS</b>	HUHNSEAL, SD: 55mm	
<b>NOTES</b>	--	

<b>VT130 G7</b>	<b>Mechanical Seal SAMS</b>	<b>POS. 1303 BF</b>
<b>PART #</b>	<b>7150</b>	
<b>CUSTOMER REFERENCE #</b>		
<b>MATERIAL</b>	316Ti/TuCKE, EPDM	
<b>SPECS</b>	HUHNSEAL, SD: 55mm	
<b>NOTES</b>	--	

<b>VT130 G7</b>	<b>Mechanical Seal DAMS</b>	<b>POS. 1303 BC</b>
<b>PART #</b>	<b>19281</b>	
<b>CUSTOMER REFERENCE #</b>		
<b>MATERIAL</b>	316Ti/SiC, FKM	
<b>SPECS</b>	HUHNSEAL, SD: 55mm	
<b>NOTES</b>	--	

<b>VT130 G7</b>	<b>Mechanical Seal DAMS</b>	<b>POS. 1303 BC</b>
<b>PART #</b>	<b>11777</b>	
<b>CUSTOMER REFERENCE #</b>		
<b>MATERIAL</b>	316Ti/SiC, EPDM	
<b>SPECS</b>	HUHNSEAL, SD: 55mm	
<b>NOTES</b>	--	

<b>VT130 G7</b>	<b>Mechanical Seal DAMS</b>	<b>POS. 1303 BC</b>
<b>PART #</b>	<b>17549</b>	
<b>CUSTOMER REFERENCE #</b>		
<b>MATERIAL</b>	316Ti/TuCKE, FKM	
<b>SPECS</b>	HUHNSEAL, SD: 55mm	
<b>NOTES</b>	--	

<b>VT130 G7</b>	<b>Mechanical Seal DAMS</b>	<b>POS. 1303 BC</b>
<b>PART #</b>	<b>17013</b>	
<b>CUSTOMER REFERENCE #</b>		
<b>MATERIAL</b>	316Ti/TuCKE, EPDM	
<b>SPECS</b>	HUHNSEAL, SD: 55mm	
<b>NOTES</b>	--	

<b>VT130 G7</b>	<b>Mechanical Seal DAMS</b>	<b>POS. 1303 BC</b>
<b>PART #</b>	<b>21661</b>	
<b>CUSTOMER REFERENCE #</b>		
<b>MATERIAL</b>	316Ti/TuC, FKM	
<b>SPECS</b>	HUHNSEAL, SD: 55mm	
<b>NOTES</b>	--	

<b>VT130 G7</b>	<b>Seal Housing</b>	<b>POS. 1029</b>
<b>PART #</b>	<b>12620</b>	
<b>CUSTOMER REFERENCE #</b>		
<b>MATERIAL</b>	316L	
<b>SPECS</b>	3A	
<b>NOTES</b>	--	

<b>VT130 G7</b>	<b>Hex Socket Screw for Seal Housing</b>	<b>POS. 2259</b>
<b>PART #</b>	<b>19098</b>	
<b>CUSTOMER REFERENCE #</b>		
<b>MATERIAL</b>	SS	
<b>SPECS</b>	M8 x 35mm	
<b>NOTES</b>	--	

<b>VT130 G7</b>	<b>Protection Shield</b>	<b>POS. 2286</b>
<b>PART #</b>	<b>18788</b>	
<b>CUSTOMER REFERENCE #</b>		
<b>MATERIAL</b>	SS	
<b>SPECS</b>	--	
<b>NOTES</b>	--	

<b>VT130 G7</b>	<b>Hex Bolt for Protection Shield</b>	<b>POS. 2287</b>
<b>PART #</b>	<b>22444</b>	
<b>CUSTOMER REFERENCE #</b>		
<b>MATERIAL</b>	SS	
<b>SPECS</b>	--	
<b>NOTES</b>	--	

**4.3 Bearing Housing**

<b>VT130 G7</b>	<b>Key for Coupling</b>	<b>POS. 1183</b>
<b>PART #</b>	<b>12619</b>	
<b>CUSTOMER REFERENCE #</b>		
<b>MATERIAL</b>	304	
<b>SPECS</b>	DIN6885, 10 x 8 x 45mm	
<b>NOTES</b>	--	

<b>VT130 G7</b>	<b>Shaft Sealing Ring Bearing Housing</b>	<b>POS. 1111</b>
<b>PART #</b>	<b>12531</b>	
<b>CUSTOMER REFERENCE #</b>		
<b>MATERIAL</b>	FKM	
<b>SPECS</b>	DIN3760-AS - 60 x 75 x 8mm, SD: 55mm	
<b>NOTES</b>	--	

<b>VT130 G7</b>	<b>Flat Gasket Gear Housing</b>	<b>POS. 2198</b>
<b>PART #</b>	<b>12494</b>	
<b>CUSTOMER REFERENCE #</b>		
<b>MATERIAL</b>	--	
<b>SPECS</b>	1mm	
<b>NOTES</b>	--	

<b>VT130 G7</b>	<b>Drive Shaft</b>	<b>POS. 1000</b>
<b>PART #</b>	<b>18760</b>	
<b>CUSTOMER REFERENCE #</b>		
<b>MATERIAL</b>	316	
<b>SPECS</b>	--	
<b>NOTES</b>	--	

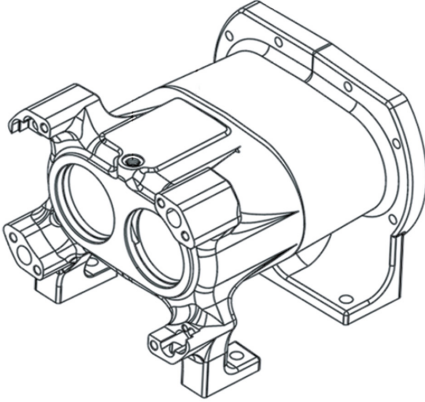

<b>VT130 G7</b>	<b>Driven Shaft</b>	<b>POS. 2171</b>
<b>PART #</b>	<b>19154</b>	
<b>CUSTOMER REFERENCE #</b>		
<b>MATERIAL</b>	316	
<b>SPECS</b>	--	
<b>NOTES</b>	--	

<b>VT130 G7</b>	<b>Bearing Housing</b>	<b>POS. 1001</b>
<b>PART #</b>	<b>19346</b>	
<b>CUSTOMER REFERENCE #</b>		
<b>MATERIAL</b>	SS	
<b>SPECS</b>	Stainless steel cast	
<b>NOTES</b>	--	

<b>VT130 G7</b>	<b>Needle Roller Bearing</b>	<b>POS. 1003</b>
<b>PART #</b>	<b>23502</b>	
<b>CUSTOMER REFERENCE #</b>		
<b>MATERIAL</b>	--	
<b>SPECS</b>	--	
<b>NOTES</b>	--	

<b>VT130 G7</b>	<b>Lock Snap Ring</b>	<b>POS. 1009 a, b</b>
<b>PART #</b>	<b>18770</b>	
<b>CUSTOMER REFERENCE #</b>		
<b>MATERIAL</b>	1.0503	
<b>SPECS</b>	Spring steel	
<b>NOTES</b>	--	

<b>VT130 G7</b>	<b>Hex Head Cap Screw for Pump Housing</b>	<b>POS. 1016</b>
<b>PART #</b>	<b>24913</b>	
<b>CUSTOMER REFERENCE #</b>		
<b>MATERIAL</b>	A2-70	
<b>SPECS</b>	ISO4017 - M16 x 85mm	
<b>NOTES</b>	--	

<b>VT130 G7</b>	<b>Hex Socket Screw for Gear Housing</b>	<b>POS. 2258</b>
<b>PART #</b>	<b>18758</b>	
<b>CUSTOMER REFERENCE #</b>		
<b>MATERIAL</b>	A270	
<b>SPECS</b>	DIN912 - M8 x 40mm	
<b>NOTES</b>	--	

<b>VT130 G7</b>	<b>Outer Spacer Ring for Ball Bearing</b>	<b>POS. 1121</b>
<b>PART #</b>	<b>18766</b>	
<b>CUSTOMER REFERENCE #</b>		
<b>MATERIAL</b>	SS	
<b>SPECS</b>	outside	
<b>NOTES</b>	--	

<b>VT130 G7</b>	<b>Inner Spacer Ring for Ball Bearing</b>	<b>POS. 1530</b>
<b>PART #</b>	<b>18767</b>	
<b>CUSTOMER REFERENCE #</b>		
<b>MATERIAL</b>	SS	
<b>SPECS</b>	inside	
<b>NOTES</b>	--	

<b>VT130 G7</b>	<b>Spacer Sleeve for Bearings</b>	<b>POS. 1529</b>
<b>PART #</b>	<b>18771</b>	
<b>CUSTOMER REFERENCE #</b>		
<b>MATERIAL</b>	SS	
<b>SPECS</b>	--	
<b>NOTES</b>	--	

<b>VT130 G7</b>	<b>Angular Ball Bearing</b>	<b>POS. 2181</b>
<b>PART #</b>	<b>23131</b>	
<b>CUSTOMER REFERENCE #</b>		
<b>MATERIAL</b>	--	
<b>SPECS</b>	SH:45mm	
<b>NOTES</b>	--	

<b>VT130 G7</b>	<b>Key for Gear Wheels</b>	<b>POS. 2179</b>
<b>PART #</b>	<b>18762</b>	
<b>CUSTOMER REFERENCE #</b>		
<b>MATERIAL</b>	SS	
<b>SPECS</b>	--	
<b>NOTES</b>	--	

<b>VT130 G7</b>	<b>Venting Valve</b>	<b>POS. 2232</b>
<b>PART #</b>	<b>18757</b>	
<b>CUSTOMER REFERENCE #</b>		
<b>MATERIAL</b>	304	
<b>SPECS</b>	G1/4"	
<b>NOTES</b>	--	

**4.4 Gear Housing**

<b>VT130 G7</b>	<b>Shaft Sealing Ring Gear Housing</b>	<b>POS. 1010</b>
<b>PART #</b>	<b>12532</b>	
<b>CUSTOMER REFERENCE #</b>		
<b>MATERIAL</b>	FKM	
<b>SPECS</b>	DIN3760-AS - 42 x 55 x 8mm, SD: 55mm	
<b>NOTES</b>	--	

<b>VT130 G7</b>	<b>Magnetic Screw Plug</b>	<b>POS. 2233</b>
<b>PART #</b>	<b>18756</b>	
<b>CUSTOMER REFERENCE #</b>		
<b>MATERIAL</b>	Aluminium	
<b>SPECS</b>	1/2"	
<b>NOTES</b>	--	

<b>VT130 G7</b>	<b>Oil Level Sight Gauge</b>	<b>POS. 1541</b>
<b>PART #</b>	<b>21766</b>	
<b>CUSTOMER REFERENCE #</b>		
<b>MATERIAL</b>	--	
<b>SPECS</b>	G3/4"	
<b>NOTES</b>	--	

<b>VT130 G7</b>	<b>Gasket for Oil Level Sight Gauge</b>	<b>POS. 1541 a</b>
<b>PART #</b>	<b>23665</b>	
<b>CUSTOMER REFERENCE #</b>		
<b>MATERIAL</b>	FKM	
<b>SPECS</b>	Gasket for Oil Level Sight Gauge	
<b>NOTES</b>	In set of 5 only	



<b>VT130 G7</b>	<b>Gear Oil Bearing Housing VT</b>	<b>POS. 2170</b>
<b>PART #</b>	<b>21871</b>	
<b>CUSTOMER REFERENCE #</b>		
<b>MATERIAL</b>	--	
<b>SPECS</b>	1 L, foodgrade	
<b>NOTES</b>	--	

<b>VT130 G7</b>	<b>Hex Socket Screw for Bearing Cover</b>	<b>POS. 1008</b>
<b>PART #</b>	<b>19341</b>	
<b>CUSTOMER REFERENCE #</b>		
<b>MATERIAL</b>	Steel 10.9	
<b>SPECS</b>	DIN6912 - M8 x 25mm, B=22mm, Low profile socket head	
<b>NOTES</b>	--	

<b>VT130 G7</b>	<b>Bearing Cover</b>	<b>POS. 1227</b>
<b>PART #</b>	<b>18772</b>	
<b>CUSTOMER REFERENCE #</b>		
<b>MATERIAL</b>	C45	
<b>SPECS</b>	--	
<b>NOTES</b>	--	

<b>VT130 G7</b>	<b>Gear Wheel Nut for Drive Shaft</b>	<b>POS. 1526</b>
<b>PART #</b>	<b>18763</b>	
<b>CUSTOMER REFERENCE #</b>		
<b>MATERIAL</b>	SS	
<b>SPECS</b>	--	
<b>NOTES</b>	--	

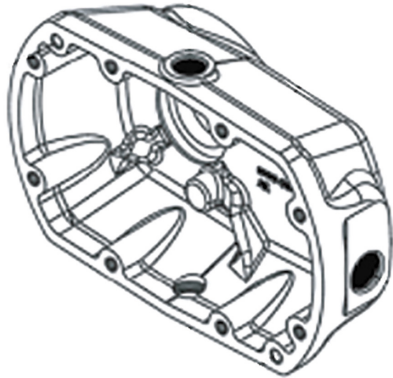
<b>VT130 G7</b>	<b>Gear Housing</b>	<b>POS. 2172</b>
<b>PART #</b>	<b>19204</b>	
<b>CUSTOMER REFERENCE #</b>		
<b>MATERIAL</b>	SS	
<b>SPECS</b>	--	
<b>NOTES</b>	--	

<b>VT130 G7</b>	<b>Gear Wheel Collar Driven Shaft</b>	<b>POS. 2176</b>
<b>PART #</b>	<b>18774</b>	
<b>CUSTOMER REFERENCE #</b>		
<b>MATERIAL</b>	--	
<b>SPECS</b>	--	
<b>NOTES</b>	--	

<b>VT130 G7</b>	<b>Hex Bolt for Driven Shaft</b>	<b>POS. 2177</b>
<b>PART #</b>	<b>18781</b>	
<b>CUSTOMER REFERENCE #</b>		
<b>MATERIAL</b>	Steel 12.9	
<b>SPECS</b>	ISO4017 - M16 x 40mm	
<b>NOTES</b>	--	

<b>VT130 G7</b>	<b>Press Ring Gear Wheel Driven Shaft</b>	<b>POS. 2178</b>
<b>PART #</b>	<b>18779</b>	
<b>CUSTOMER REFERENCE #</b>		
<b>MATERIAL</b>	--	
<b>SPECS</b>	--	
<b>NOTES</b>	--	

<b>VT130 G7</b>	<b>Gear Wheel Drive Shaft</b>	<b>POS. 2183</b>
<b>PART #</b>	<b>18799</b>	
<b>CUSTOMER REFERENCE #</b>		
<b>MATERIAL</b>	AISI 5115, hardened	
<b>SPECS</b>	--	
<b>NOTES</b>	--	

<b>VT130 G7</b>	<b>Gear Wheel Driven Shaft</b>	<b>POS. 2184</b>
<b>PART #</b>	<b>18800</b>	
<b>CUSTOMER REFERENCE #</b>		
<b>MATERIAL</b>	AISI 5115, hardened	
<b>SPECS</b>	--	
<b>NOTES</b>	--	

<b>VT130 G7</b>	<b>Hex Socket Screw for Gear Synchronization Lock Ring</b>	<b>POS. 2186</b>
<b>PART #</b>	<b>18782</b>	
<b>CUSTOMER REFERENCE #</b>		
<b>MATERIAL</b>	Steel 12.9	
<b>SPECS</b>	DIN912 - M5 x 25mm	
<b>NOTES</b>	--	

<b>VT130 G7</b>	<b>Dowel Pin for Gear Housing</b>	<b>POS. 2256</b>
<b>PART #</b>	<b>18764</b>	
<b>CUSTOMER REFERENCE #</b>		
<b>MATERIAL</b>	303	
<b>SPECS</b>	DIN7 - 8m6 x 20mm, undersize	
<b>NOTES</b>	--	

<b>VT130 G7</b>	<b>Lock Washer for Bearing Cover Screw</b>	<b>POS. 2326</b>
<b>PART #</b>	<b>19081</b>	
<b>CUSTOMER REFERENCE #</b>		
<b>MATERIAL</b>	--	
<b>SPECS</b>	--	
<b>NOTES</b>	--	

**4.5 Drive Train**

<b>VT130 G7</b>	<b>Pump Hub 42/55</b>	<b>POS. 2247</b>
<b>PART #</b>	<b>21703</b>	
<b>CUSTOMER REFERENCE #</b>		
<b>MATERIAL</b>	Aluminium	
<b>SPECS</b>	BS:35mm	
<b>NOTES</b>	--	

<b>VT130 G7</b>	<b>Motor Hub 42/55 NEMA 21X</b>	<b>POS. 2248</b>
<b>PART #</b>	<b>21704</b>	
<b>CUSTOMER REFERENCE #</b>		
<b>MATERIAL</b>	Aluminium	
<b>SPECS</b>	SIT, BS:1-3/8"	
<b>NOTES</b>	--	



<b>VT130 G7</b>	<b>Motor Hub 42/55 NEMA 25X</b>	<b>POS. 2248</b>
<b>PART #</b>	<b>21705</b>	
<b>CUSTOMER REFERENCE #</b>		
<b>MATERIAL</b>	Aluminium	
<b>SPECS</b>	SIT, BS:1-5/8"	
<b>NOTES</b>	--	

<b>VT130 G7</b>	<b>Motor Hub 42/55 NEMA 28X</b>	<b>POS. 2248</b>
<b>PART #</b>	<b>21706</b>	
<b>CUSTOMER REFERENCE #</b>		
<b>MATERIAL</b>	Aluminium	
<b>SPECS</b>	SIT, BS:1-7/8"	
<b>NOTES</b>	--	

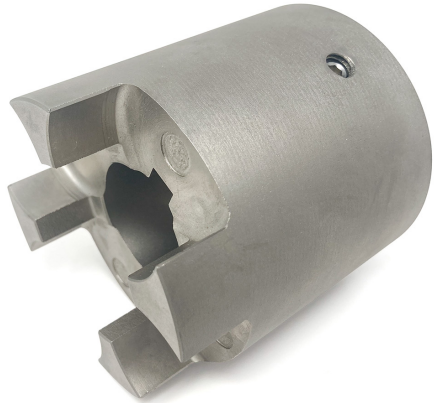
<b>VT130 G7</b>	<b>Motor Hub 42/55 NEMA 32X</b>	<b>POS. 2248</b>
<b>PART #</b>	<b>21707</b>	
<b>CUSTOMER REFERENCE #</b>		
<b>MATERIAL</b>	Aluminium	
<b>SPECS</b>	SIT, BS:2-1/8"	
<b>NOTES</b>	--	

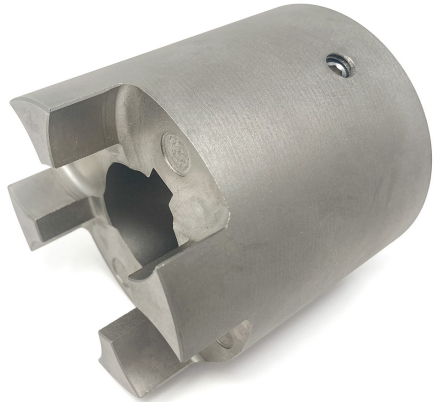
<b>VT130 G7</b>	<b>Motor Hub 42/55 NEMA 21X</b>	<b>POS. 2248</b>
<b>PART #</b>	<b>22196</b>	
<b>CUSTOMER REFERENCE #</b>		
<b>MATERIAL</b>	Aluminium	
<b>SPECS</b>	SIT, BS:2-3/8"	
<b>NOTES</b>	--	

<b>VT130 G7</b>	<b>Coupling Spider 42/55 Red</b>	<b>POS. 2249</b>
<b>PART #</b>	<b>7115</b>	
<b>CUSTOMER REFERENCE #</b>		
<b>MATERIAL</b>	PU	
<b>SPECS</b>	SIT 42/55 98, red	
<b>NOTES</b>	--	

<b>VT130 G7</b>	<b>W22 Severe Duty Motor</b>	<b>POS. 3003</b>
<b>PART #</b>	<b>various</b>	
<b>CUSTOMER REFERENCE #</b>		
<b>MATERIAL</b>	variable	
<b>SPECS</b>	variable	
<b>NOTES</b>	--	