

# ViscoTwin G10

pumps everything • better

---

# Features of Twin Screw Pumps

Twin Screw Pumps are versatile, capable of handling a wide range of media—from air and vapor to water and highly viscous products like silicone. Their working principle supports hygienic design, making them ideal for sanitary applications. As volumetric pumps, they operate as Positive Displacement (PD) pumps, ensuring consistent and efficient performance.

Twin Screw Pumps offer efficiency comparable to standard centrifugal pumps when handling water. However, as media viscosity increases, centrifugal pumps lose efficiency, while Twin Screw Pumps excel. Reduced slip and lower RPMs allow Twin Screw Pumps to maintain superior performance with thicker fluids.

When a PD pump is required, Twin Screw Pumps offer simplicity in both installation and operation. They handle a wide range of applications with ease, including CIP solutions, thin and thick media, sensitive products with chunks, air/water mixtures, slurries, high-viscosity concentrates (up to 650 psi), and sterile processes under the highest hygienic standards.

---

## Comparison of typical system setup

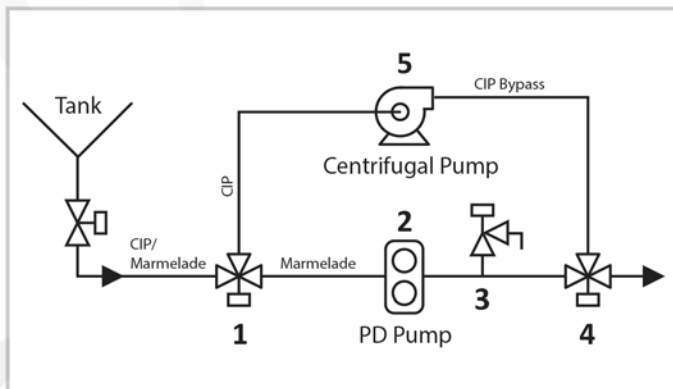

**with PD Pump  
(5 devices)**

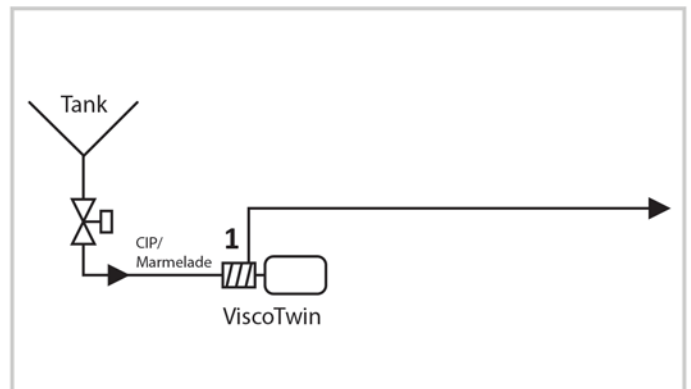

**with ViscoTwin  
(1 device)**

# The ViscoTwin G10

- The pump housing is designed to gently move sensitive particulates like macaroni in cheese sauce, chunks in soups or cheese curd in whey.
- Viscosities ranging from water in air (0.3cps) to Silicone (1 Mio cps).
- Very high suction capability (low NPSHr) at 46 mbar(a).
- Max discharge Pressure with E-Spindles at 45 bar (650psi).
- Max operating temperature at 380°F with FFKM Elastomers.
- High suction capability as mixed phase pump with 70% air in 30% liquid.
- Fully bi-directional operation due to 4 bearings per shaft, 2 bearings for pull and 2 bearings for push.
- Customizable as sterile pump with steam/condensate barrier.
- Many seal, pump face, frame and coupling options available.
- Safety First! The ViscoTwin is built with your operators and technicians in mind.



Properties	ViscoTwin 70	ViscoTwin 104	ViscoTwin 130
Standard Pressure max	25 bar (360 psi)	25 bar (360 psi)	25 bar (360 psi)
High Pressure max	45 bar (650 psi)	45 bar (650 psi)	45 bar (650 psi)
Shaft RPM max	5000 rpm	5000 rpm	5000 rpm
Standard Temp max	130°C (266°F)	130°C (266°F)	130°C (266°F)
High Temp max	180°C (356°F)	180°C (356°F)	180C (356°F)
Viscosity	0.1 to 1 Mio mPas	0.1 to 1 Mio mPas	0.1 to Mio mPas
Particulate Size S-Spindle	21mm	26mm	32mm
Pump Face max	DN80 / OD3"	DN100 / OD4"	DN150 / OD6"
Pump Face std	DN80 / OD3"	DN80 / OD3"	DN100 / OD4"
Pump Housing	DN65 / OD2.5"	DN80 / OD3"	DN100 / OD4"

# Why ViscoTwin?

- **FAST ACCESS FOR INSPECTION**

Just remove the FOUR (4) bolts to gain access to the Mechanical Seals, for inspection or cleaning.

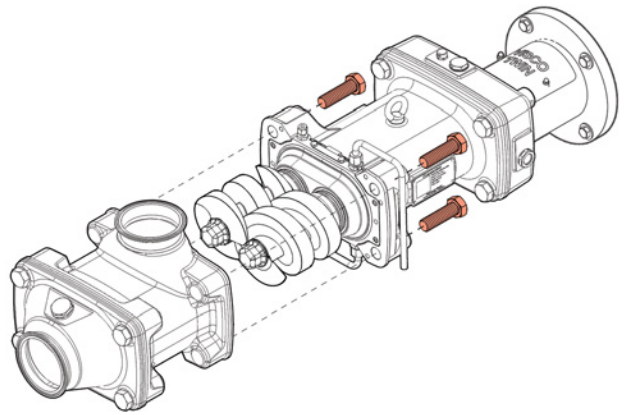

- **GENTLE PRODUCT FLOW**

The ViscoTwin G10 is designed to handle sensitive products without tearing or destroying large particulates. From berries to noodles, the ViscoTwin G10 pumps it with care!



- **MANY WAYS TO CONFIGURE**

ViscoTwin G10's are highly configurable to optimize various application requirements and installation setups.



- **EASY TO OPERATE & MAINTAIN**

Once installed, all parts used to build the ViscoTwin G10 are designed for max durability, reliability, performance and are easy to maintain.

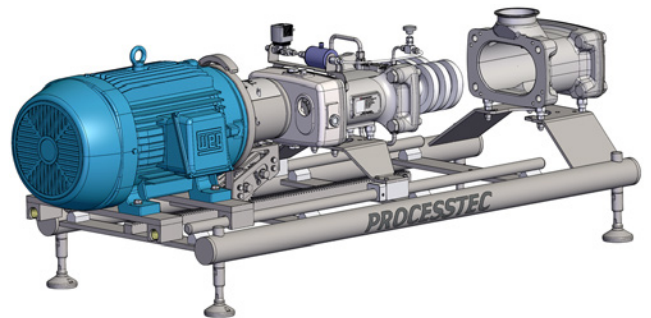

- **COMPLETE ONLINE SUPPORT**

Get immediate access to support documentation that is available online: Manuals, Explosion Drawings, Torque Charts, Spare Parts Catalogs, How-to Movies, Online Sizing Software and Configuration Charts. All of these are available online at [processtec.com](http://processtec.com)



# ViscoTwin G10 Pump Face Options



The **STANDARD PUMP FACE** is optimized to gently move the product from the inlet pipe to the conveying area of the spindles. All tearing edges are removed, which greatly improves the suction properties of the pump (NPSHr). Each pump face is equipped with an Aseptoflex port to flush-mount an IFM vacuum gauge.



The **DUAL INLET PUMP FACE** is designed to conjoin two product streams at the pump head. The design of the product flow prevents "bridge" building in the suction pipes.



The **WELD-IN FLANGE** is used for close-coupled installation of the pump to a tank or auger in case the product is too viscous to flow through a valve and pipe into the pump.

# ViscoTwin G10 Frame Options (1-6)

The **ViscoTwin G10** pump is available by itself, or mounted to a custom developed **Frame** to meet your needs. Whether you need to fit into tight spaces (**Frame 6**) or gain total mobility (**Frame 5**), **PROCESSTEC** offers a solution.

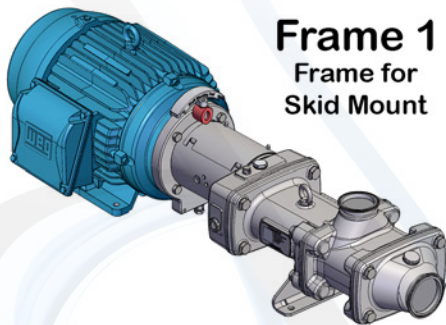

**Frame 1**  
Frame for  
Skid Mount

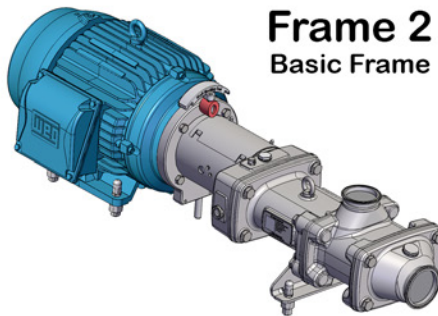

**Frame 2**  
Basic Frame

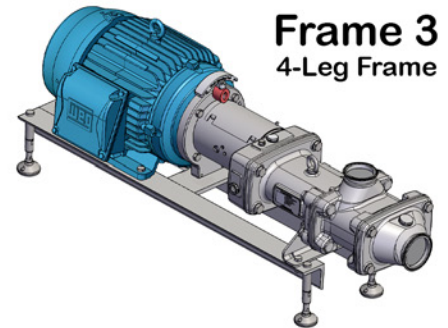

**Frame 3**  
4-Leg Frame

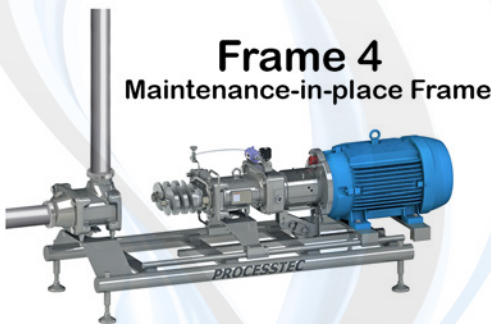

**Frame 4**  
Maintenance-in-place Frame

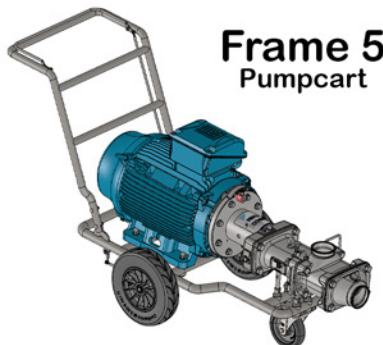

**Frame 5**  
Pumpcart

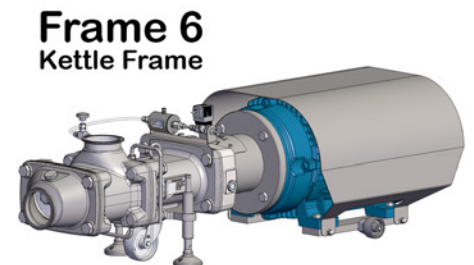

**Frame 6**  
Kettle Frame

# ViscoTwin G10 Coupling Options



**Standard Coupler**

Each pump coupler includes a custom bore to insert a Shaft Blocking Tool for safe spindle bolt loosening & tightening.



**Disengaging Coupler  
(Torque Limiter)**

This option automatically disengages the Motor Shaft from the Pump Drive Shaft in the event of a blockage in the Spindle Area, preventing catastrophic damage to the pump. The pump coupler also hosts the bore for the Shaft Blocking Tool.

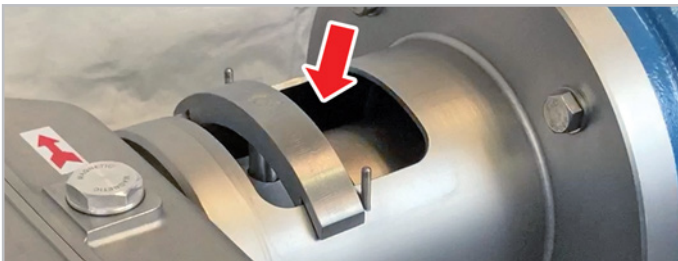

# ViscoTwin G10 High Pressure Options

In case pressures above 360 psi are required, **PROCESSTEC** offers customized system upgrades for 650 psi and 375° F operation. This is limited to selected spindle pitches, therefore limiting max flowrate and min product viscosity.

<b>High Pressure Flow Rates at 650 psi (with Oil Cooler)</b>						
Model	Flow Rate	Speed	Pressure	Viscosity	Torque	Motor
VT70.22	57 GPM	3,400 rpm	650 psi	1,000 cps	61 lb-ft	40 hp
VT104.27	112 GPM	3,400 rpm	650 psi	1,000 cps	137 lb-ft	100 hp
VT130.33	222 GPM	3,400 rpm	650 psi	1,000 cps	250 lb-ft	200 hp

# Behind the Scenes

- Our brand new facility allows us to build our pumps right here in the United States.
- High quality fabrication is done in-house by our team of skilled technicians.
- Our fabrication shop allows us to innovate and develop custom solutions.
- We've invested in the proper equipment to make sure our pumps are produced in a safe and environmentally friendly manner.
- We keep a large supply inventory of spare parts on hand to service your pumps well into the future.
- Having total control of the production process allows us to maintain a high level of quality in our product line.
- Each ViscoTwin pump is rigorously tested before being shipped out to the customer.

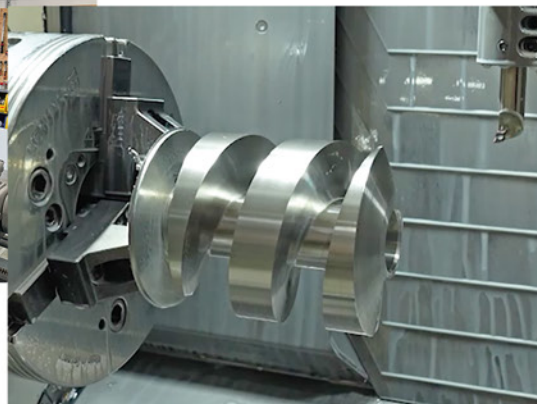

VT Twin Screw Pump: Flow by Viscosity, sample at 80 psi

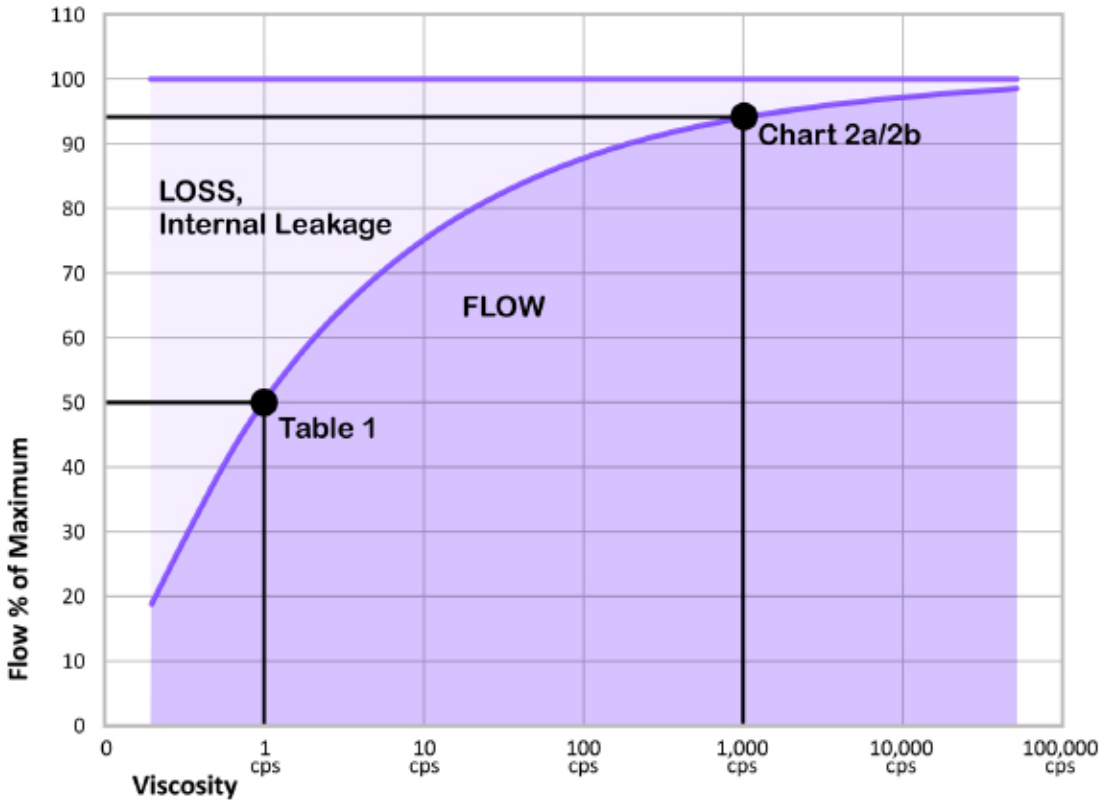

**Pump Sizing Program**

We developed custom software that helps you find the perfect size for your ViscoTwin pump.

**Pumping CIP-Solution @ Viscosity 1cps**

**TABLE 1**

Pump Model	Largest Pipe Size for CIP	Speed in Line	Flow Rate	Discharge Pressure	Shaft RPM	Shaft Torque	Motor @ 1780 rpm	Frequency with 1780 rpm Motor
VT70.22	OD1.5"	6.0 ft/sec	28 GPM	30 psi	2,435 rpm	5.7 lb-ft	3.0 hp	82 Hz
VT70.29	OD2.0"	6.0 ft/sec	51 GPM	30 psi	3,130 rpm	6.1 lb-ft	5.0 hp	106 Hz
VT70.43	OD2.5"	6.0 ft/sec	83 GPM	30 psi	3,595 rpm	7.2 lb-ft	5.0 hp	121 Hz
VT104.27	OD2.5"	6.0 ft/sec	83 GPM	30 psi	2,785 rpm	15.3 lb-ft	10.0 hp	94 Hz
VT104.36	OD3.0"	6.0 ft/sec	121 GPM	30 psi	3,118 rpm	16.5 lb-ft	10.0 hp	105 Hz
VT104.53	OD3.0"	6.0 ft/sec	121 GPM	30 psi	2,182 rpm	16.5 lb-ft	10.0 hp	74 Hz
VT104.53	OD4.0"	6.5 ft/sec	238 GPM	30 psi	3,844 rpm	18.4 lb-ft	15.0 hp	130 Hz
VT130.33	OD3.0"	6.0 ft/sec	121 GPM	30 psi	2,088 rpm	21.7 lb-ft	15.0 hp	70 Hz
VT130.33	OD4.0"	6.5 ft/sec	238 GPM	30 psi	3,482 rpm	21.2 lb-ft	15.0 hp	117 Hz
VT130.44	OD4.0"	6.5 ft/sec	238 GPM	30 psi	2,900 rpm	23.5 lb-ft	15.0 hp	98 Hz
VT130.65	OD4.0"	6.5 ft/sec	238 GPM	30 psi	2,090 rpm	28.0 lb-ft	15.0 hp	70 Hz
VT130.65	OD5.0"	6.5 ft/sec	377 GPM	30 psi	3,086 rpm	27.6 lb-ft	20.0 hp	104 Hz
VT130.65	OD6.0"	6.5 ft/sec	548 GPM	30 psi	4,330 rpm	27.3 lb-ft	25.0 hp	146 Hz



# Slurries and Concentrates

Viscosity 1000 cps  
 Pressure 100 psi  
 Shaft Speed 1780 rpm

## CHART 2a

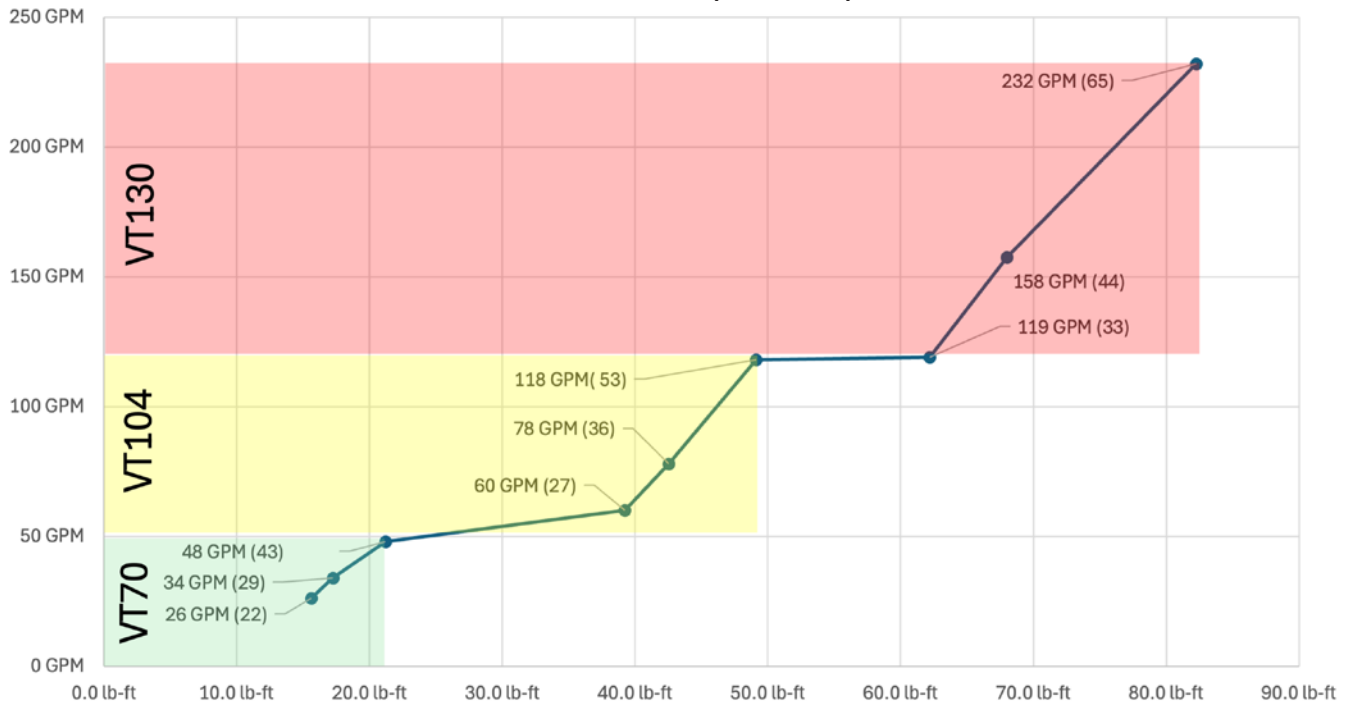

# Sensitive Particulates

Viscosity 1000 cps  
 Pressure 58 psi  
 Shaft Speed 600 rpm

## CHART 2b

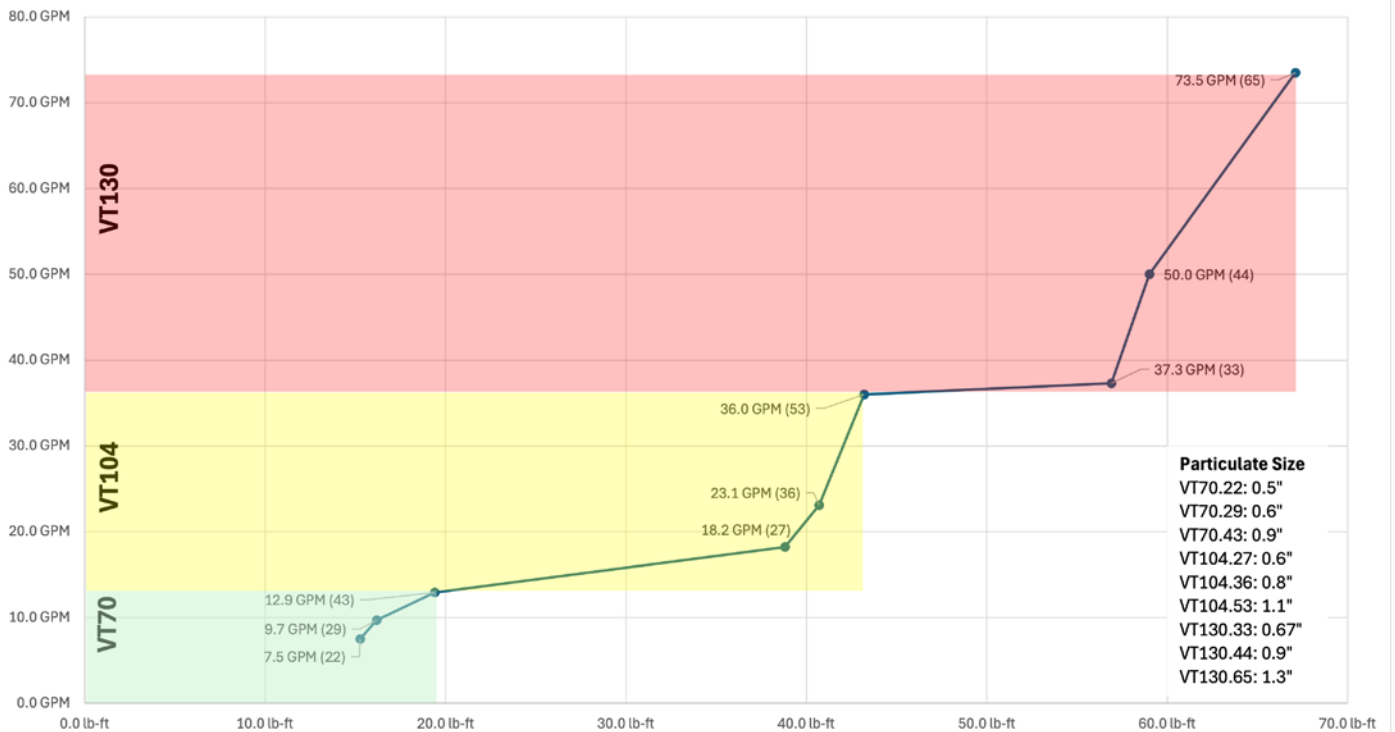

# THESE 27 KEY INNOVATIONS FOR THE VISCOTWIN G10 WERE INSPIRED BY ACTUAL IN-FIELD EXPERIENCE FROM PROCESSTEC TECHNICIANS!

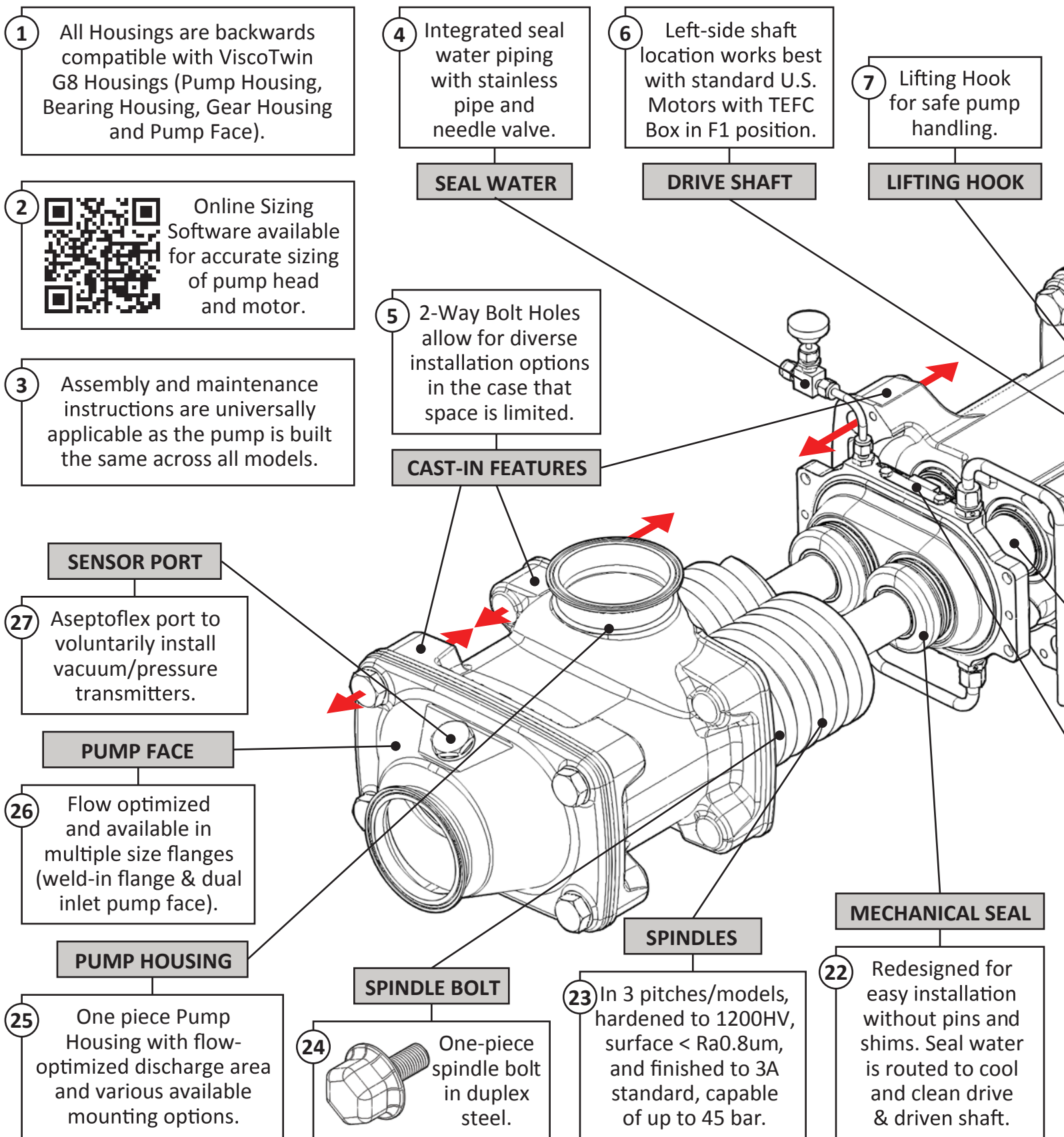

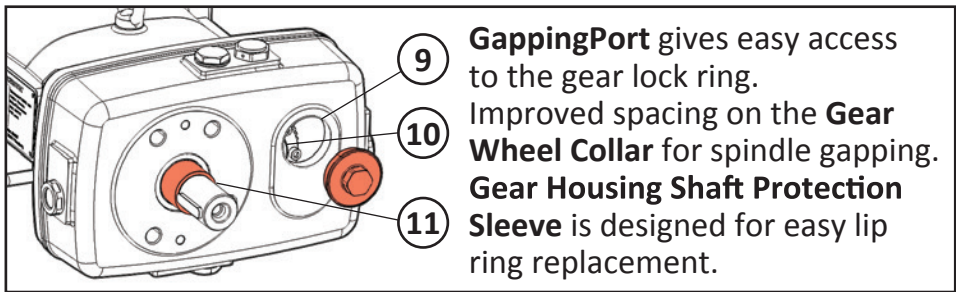

- 9 **GappingPort** gives easy access to the gear lock ring.
- 10 Improved spacing on the **Gear Wheel Collar** for spindle gapping.
- 11 **Gear Housing Shaft Protection Sleeve** is designed for easy lip ring replacement.

12 The lantern perfectly aligns the motor coupling and allows the pump to attach to a motor without a pump frame, keeping the coupling accessible for inspection and re-engagement. The lantern stores the Shaft Blocking Tool, and also secures it in place when in use. Perfectly sized for disengaging couplings.

**GEAR HOUSING**

**LANTERN**

8 Air Vent/  
Breather Port  
with Moisture  
Filter.

**AIR VENT**

13 Block mounting for all common motors & gear motors for all ViscoTwin models.

**MOTOR**

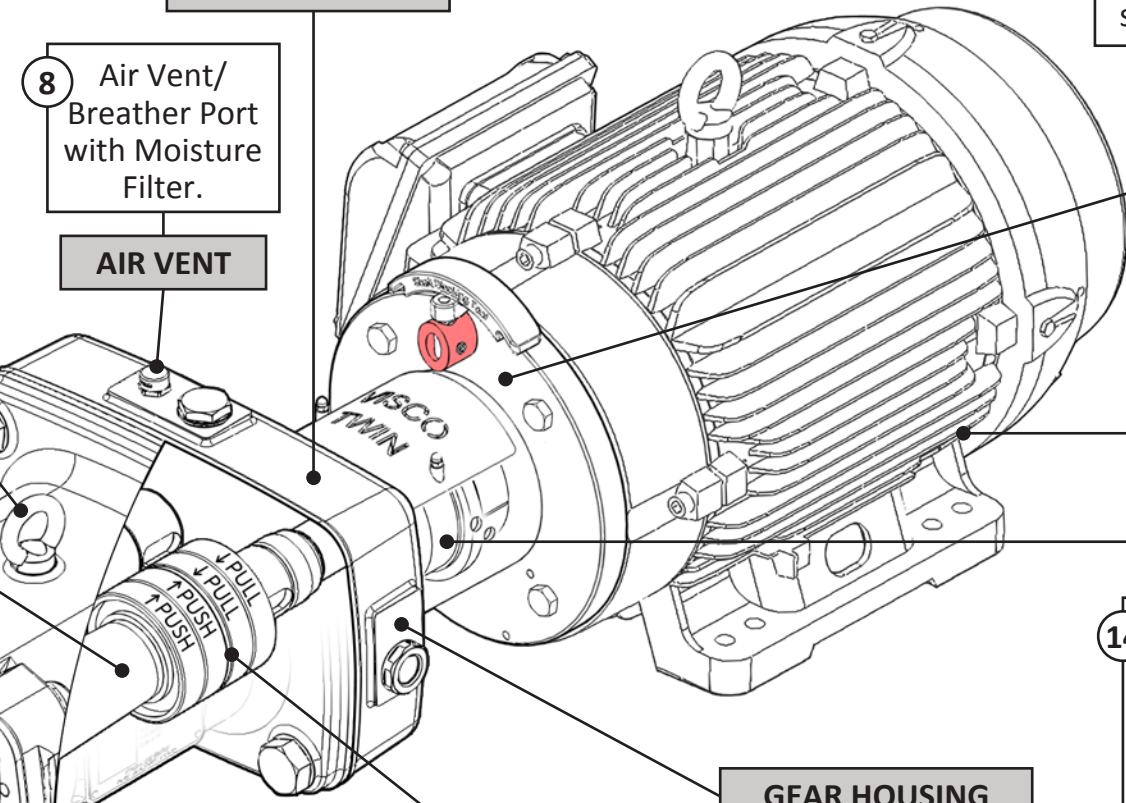

**COUPLING OPTIONS**

**SKF BEARINGS**

19 Four (4) Premium **SKF Explorer Series Bearings**, with 2 for pull and 2 for push.

**GEAR HOUSING**

- 16 In stainless 1.4308/304, equipped with **oil gauges on each side, 1 gapping port**, 1 oil inlet, 1 oil discharge & 1 breather. The Driven Shaft is left-side mounted by default with an **option for right-side mount**.
- 17
- 18

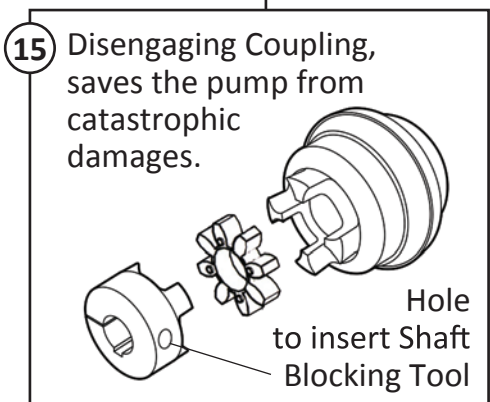
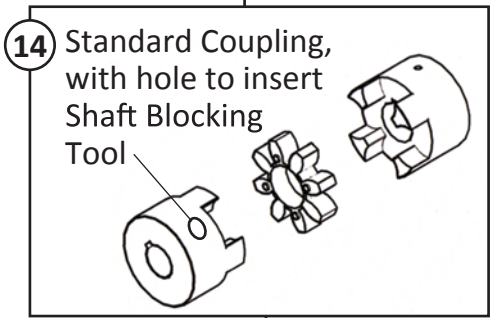

**SHAFT PROTECTION SLEEVES**

**SAFETY GUARD**

21 Large one-piece safety guard for easy installation.

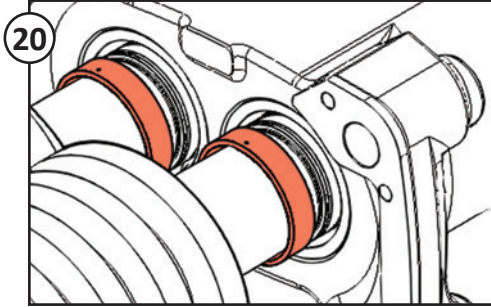

20 Hardened shaft protection sleeves are designed with two holes for easy removal, making it easy to replace the sealing rings without pump teardown.

**PROCESSTEC**  
For more information,  
please contact us at  
[sales@processtec.com](mailto:sales@processtec.com)

**Pumping Tomato Sauce**  
**3 pumps x 250 gpm @ 150 psi = 750 gpm**  
**(4 pumps = 1000 gpm)**

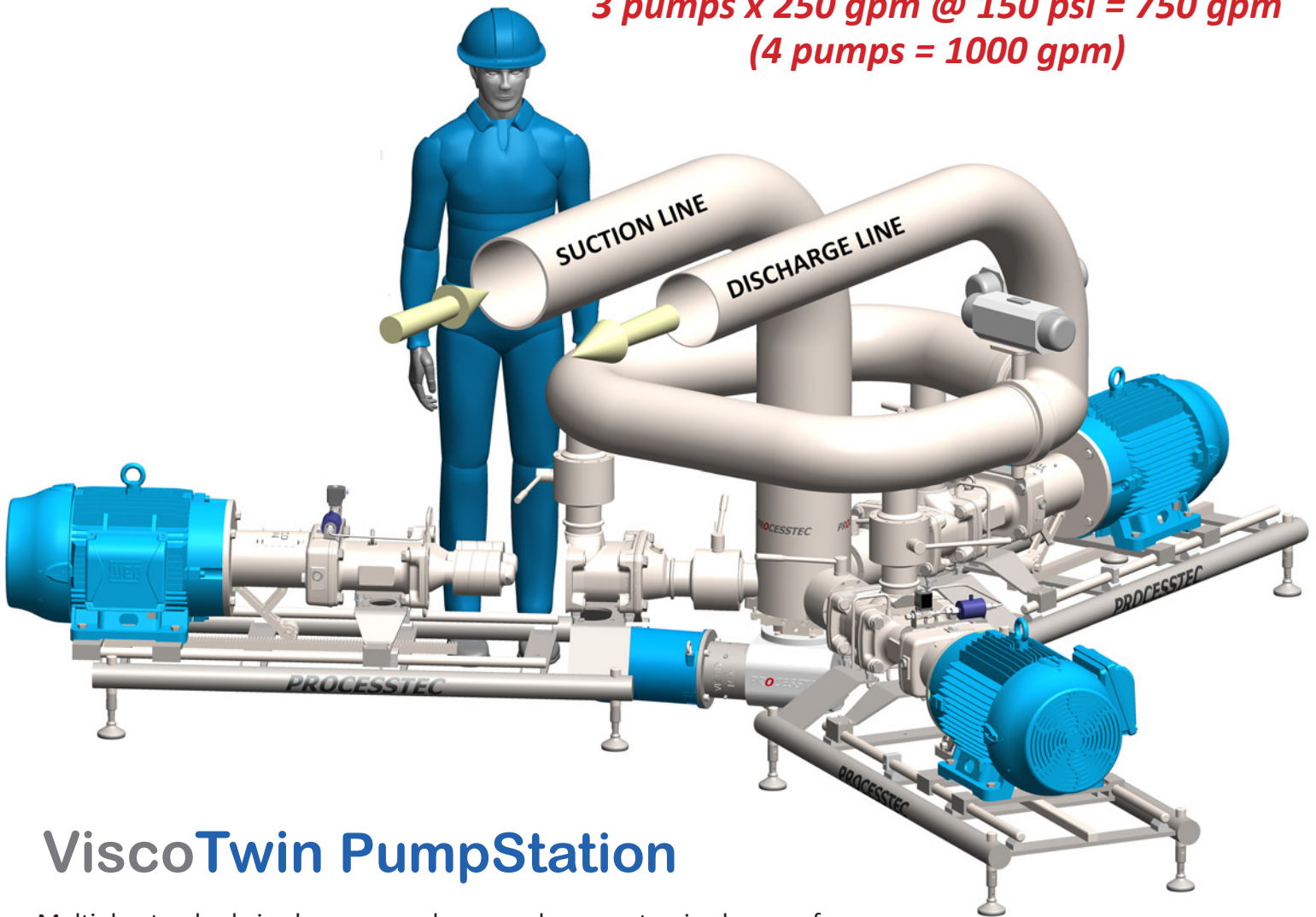

## ViscoTwin PumpStation

Multiple standard-sized pumps replace one large customized pump for safe and continuous operation. The **ViscoTwin PumpStation** features a sanitary design and dead-zone free operation. The M.I.P. Frame #4 enables pump inspection and maintenance without live shutdown. Commercial Airplanes operate more than one engine simultaneously too!



**PROCESSTEC, Inc.**  
9938 West Legacy Ave  
Visalia, CA 93291

Phone: +1 (559) 429-4227  
Fax: +1 (559) 429-4228  
Email: [info@processtec.com](mailto:info@processtec.com)  
<http://processtec.com>

Browse the  
ViscoTwin  
Downloads  
Overview Page

