

# **PROCESSTEC**

GET TOMORROW'S TECHNOLOGY TODAY

## **ViscoTwin 104 G8+, NG**

### **Operation & Maintenance Manual**

Published January 10th, 2024



Address: 345 E. Tulare Avenue Unit E | Visalia, CA 93277 | Phone: +1 (559) 429-4227  
Fax: +1 (559) 429-4228 | Email: [info@processtec.com](mailto:info@processtec.com) | <http://processtec.com>

---



---

<b>1. ABOUT VISCOTWIN SCREW PUMPS</b> .....	<b>1</b>
1.1 Safety Notes .....	1
1.2 Working Principle .....	3
1.3 General Overview .....	4
1.4 Options .....	5
1.4.1 Options for 3A or EHEDG .....	5
1.4.2 Pump Face Options .....	6
1.4.3 Pump Housing Options .....	8
1.4.4 Elastomer Options .....	10
1.4.5 Spindle Options .....	11
1.4.6 Mechanical Seal Options .....	12
1.4.7 Bearing Housing Options .....	14
1.4.8 Motor Options .....	17
1.4.9 Frame Options .....	18
1.5 Performance Tables .....	19
1.5.1 Sizing Chart .....	19
1.5.2 Water Curves .....	21
<b>2. INSTALLATION</b> .....	<b>23</b>
2.1 Unpacking .....	23
2.2 Inspection / Technical Documentation .....	23
2.3 Hoisting and Transportation .....	24
2.4 Installation .....	26
2.5 Piping Before and After the Pump .....	27
2.5.1 Upstream Piping .....	27
2.5.2 Downstream Piping .....	28
2.5.3 Piping Before and After the Pump .....	28
2.6 Mechanical Seal Connection .....	29
2.7 Pre-Installation of Seal Water for Dual Acting Mechanical Seal .....	30
2.8 Electrical Installation .....	31
<b>3. OPERATION</b> .....	<b>33</b>
3.1 Pump Startup .....	33
3.2 Soft Starting the Pump .....	33
3.3 Avoiding Pump Cavitation .....	34
3.4 Pumping Sensitive Products .....	34
3.5 Material Selection for Sealing Surfaces .....	35
3.6 Pumping Product with Large Particulates .....	35

---

3.7 High Pressure Systems . . . . .	35
3.8 CIP / COP Solution. . . . .	36
3.9 Visual Inspection . . . . .	37
3.10 Available Elastomer Options . . . . .	37
3.11 Leakage . . . . .	38
3.12 Scratches in the Pump Housing . . . . .	39
<b>4. MAINTENANCE . . . . .</b>	<b>41</b>
4.1 Maintenance Preparation. . . . .	41
4.1.1 General Movie: HOW THE PUMP WORKS. . . . .	41
4.1.2 Introduction to Web Page . . . . .	41
4.1.3 Risk Assessment for Pump Maintenance . . . . .	42
4.1.4 Safety Measures . . . . .	42
4.2 Explaining Maintenance Levels . . . . .	43
4.2.1 Maintenance Level 1 (ML-1) . . . . .	43
4.2.2 Maintenance Level 2 (ML-2) . . . . .	44
4.2.3 Maintenance Level 3 (ML-3) . . . . .	45
4.3 Material at hand, Required Parts & Tools . . . . .	46
4.3.1 Recommended Spare Parts . . . . .	46
4.3.2 Recommended Tools . . . . .	47
4.3.3 Recommended Oils, Grease. . . . .	47
4.4 Maintenance Instructions for ML-2. . . . .	48
4.4.1 Removing the Pump Housing . . . . .	48
4.4.2 Complete Pump Disassembly . . . . .	51
4.4.3 Complete Pump Assembly . . . . .	57
4.5 Preventative Maintenance Program . . . . .	65
4.5.1 First Oil Change. . . . .	65
4.5.2 Oil Change Intervals . . . . .	65
4.5.3 Checking Levels on Motor Gearbox Oil. . . . .	65
4.5.4 Greasing Motor Bearings . . . . .	65
4.5.5 Check Condition of O-rings . . . . .	66
4.5.6 Check the Exterior Lip Seals and O-rings on the Mechanical Seals . . . . .	66
4.5.7 Check Oil Shaft Sealing Rings. . . . .	67
4.5.8 Proper Gapping of Pump . . . . .	68
4.5.9 Changing Product Flow Direction . . . . .	72
4.6 Failures. . . . .	73
4.6.1 Foreign Material enters Pump Housing . . . . .	73

---

<b>5. TOOL-BOX</b> .....	<b>75</b>
5.1 Tools .....	75
5.1.1 ViscoTwin Tools .....	75
5.1.2 General Tools .....	79
5.2 Spare Parts .....	85
5.2.1 Spare Parts for Pump Housing .....	85
5.2.2 Spare Parts for Seal Housing .....	89
5.2.3 Spare Parts for Bearing Housing .....	92
5.2.4 Spare Parts for Gear Housing .....	93
5.2.5 Spare Parts for Drive Train .....	95
5.3 Explosion Drawings .....	98
5.4 Torque Tables .....	99
5.5 Pump Housing Configuration .....	100
5.6 Oils, Grease & Lubrication Recommended .....	108
5.7 Oil Testing Kit (with Form) .....	110
<b>6. GEEK'S CORNER</b> .....	<b>112</b>
6.1 Oil Cooler with Oil Filter .....	112
6.2 Vibration Sensor with Oil Temperature Sensors .....	113
6.3 Quench Design for Recirculating Fluids in Mechanical Seals .....	114
6.4 Maximizing Bearing Lifespan .....	115
6.5 Equipment Commissioning Protocol .....	125

*This page intentionally left blank.*

## 1. ABOUT VISCOTWIN SCREW PUMPS

### 1.1 Safety Notes

This manual contains instructions which should be heeded to ensure personal safety and prevent damage to property. These instructions are highlighted by a warning triangle and a color to indicate the degree of the hazard. The following warnings should be observed throughout the life cycle of the pump:



#### **ROTATING PARTS**

Indicates rotating parts that can cause injury. Only perform work on or near these parts when it is locked to prevent rotation. It is advised to have a protective barrier surrounding the rotating part to prevent injury or property damage during operation.



#### **HIGH VOLTAGE**

Indicates high voltage and risk of shock or severe burns. No work should be performed around high voltage parts unless they have been disconnected from the main power supply. Any work on high voltage parts must only be performed by an electrician licensed in the state where operations and maintenance is being performed.



#### **CRUSHING PARTS**

Indicates moving parts that can crush and cut. Perform work with awareness of how parts move and where these crushing parts can be encountered.



#### **SUSPENDED LOAD**

Indicates a suspended or overhung load, where parts can fall, slip, or tip over if not properly secured. Do no work on any part that is suspended and avoid being directly under or near a suspended load. Do not stand between a stationary object and a suspended load.



#### **LIFTING OBJECTS**

Indicates heavy objects that can cause muscle strain or back injury. Lifting aids and proper lifting techniques should be used to prevent injury.



**LEAKAGES**

Indicates that leaks are possible. Leaked fluid can cause slip-and-fall hazards and should be cleaned up and disposed of immediately.



**HOT SURFACE**

Indicates a surface is hot to the touch and can cause burn injury. Do not maintain or touch a hot surface until the pump is turned off and allowed to cool. If immediate repair is necessary, it is advised to wear protective gloves while handling a hot part.



**NOTE!**

**CAUTION**

When operating the **ViscoTwin 104 G8**, it is essential to wear appropriate protective equipment.

Commissioning and operating the **ViscoTwin 104 G8+, NG** may only be performed by qualified personnel. Qualified personnel in terms of the safety instructions in this operating and safety manual are persons who have completely read this manual.

Furthermore, maintenance can only be performed by qualified maintenance technicians. Qualified maintenance technicians in terms of the maintenance instructions in this operating and safety manual are persons who have read Chapter 4 "Maintenance" and have been trained by **Processtec** in the use and maintenance of this pump. In lieu of in-person training by **Processtec** personnel, a qualified maintenance technician may also review the online maintenance movies available at <http://processtec.com>. **WARNING: ANY MAINTENANCE LEVEL 2 PERFORMED ON THIS PUMP BY UNTRAINED PERSONNEL WITHOUT THE EXPRESS WRITTEN CONSENT OF PROCESSTEC WILL RELEASE PROCESSTEC OF ANY LIABILITY AND VOID ANY WARRANTY CLAIMS ON THE PUMP..**

In addition to this operating manual, general on-site regulations as well as city, state, and federal regulations applicable to accident prevention must be made available and followed.

The **ViscoTwin 104 G8+, NG** may only be used in the applications as specified in Chapter 3 "Operation" on page 33, and only in connection with the spare parts recommended by **Processtec, Inc.**



## **1.2 Working Principle**

Screw pumps are rotary positive displacement pumps for conveying low to high viscosity media. The **ViscoTwin G8+, NG** is a positive displacement pump characterized by a double screw, or spindle, design. The pump utilizes very close tolerances to create a series of “sealed” chambers between spindle windings. This allows the pump to more efficiently transport highly viscous product with minimal slippage and precision flowrate control as well as gentle handling of solid particulates already mixed into the product. The precision craftsmanship of the **ViscoTwin G8+, NG** means it can generate a very high pressure differential, even with a low inlet pressure.

The pump is also highly customizable, with several sizes and inlet/outlet variations to suit the needs of the product and the space available. Additionally, the pump is maintenance friendly and fully CIP-able, to ensure ease of use.

**ViscoTwin G8+, NG** pumps used in the food and beverage industry are designed to meet the most stringent sanitary design criteria (3A, EHEDG), and are built with corrosion-resistant materials in accordance with recommendations from US Food and Drug Administration (FDA) and other international food safety governing bodies. Pumps are delivered with a motor, lantern, and framing as standard for easy installation.

**1.3 General Overview**

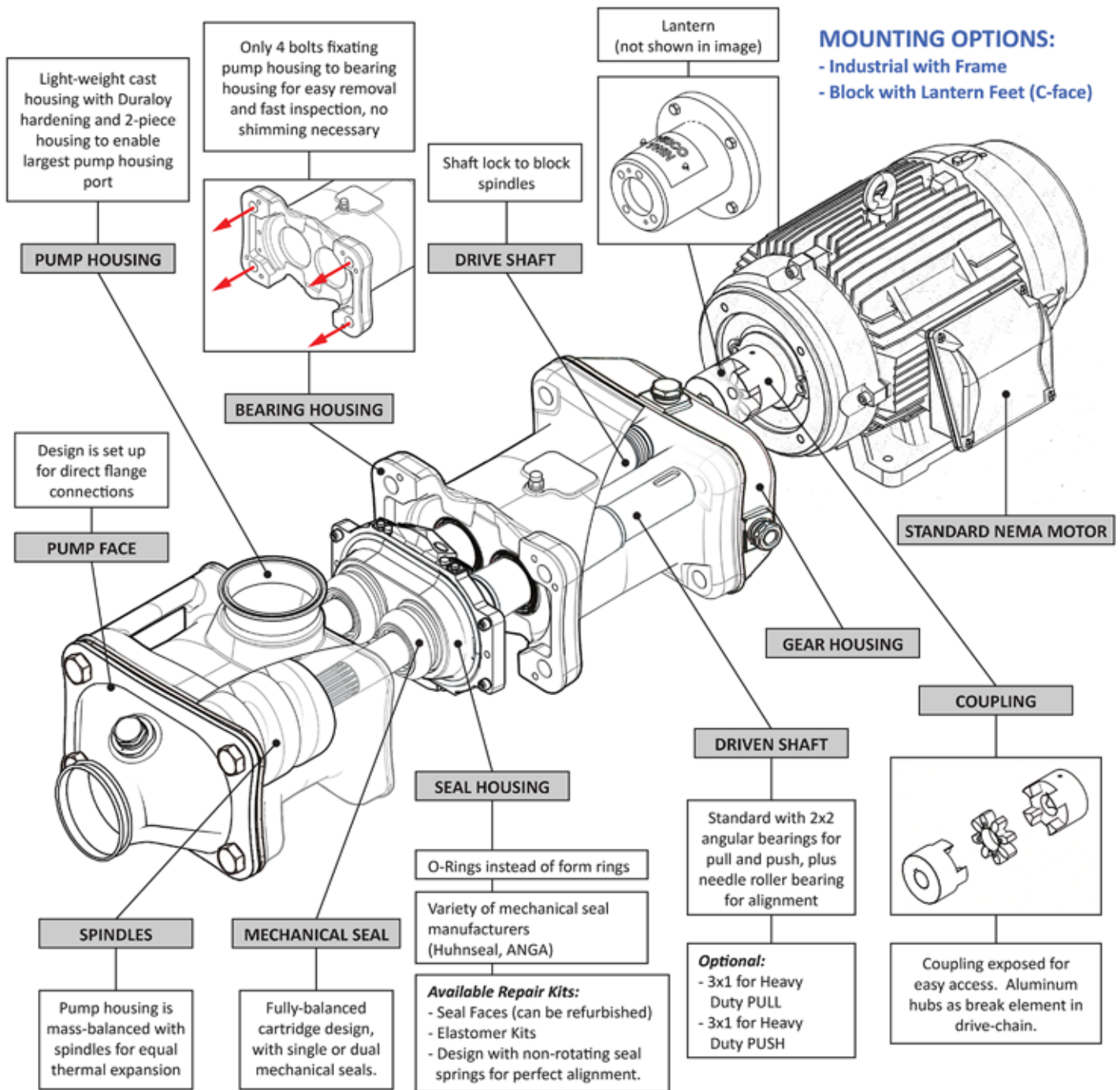

## 1.4 Options

### 1.4.1 Options for 3A or EHEDG

All **ViscoTwin** pump models including all associated options as listed throughout this Section 1.4 are designed according 3A and EHEDG guidelines. General design and detail design considerations like radii, O-ring grooves, surface treatment, material, and elastomer selection fulfill both norms.



Only pumps for the US dairy industry require the 3A symbol attached to it. The only difference is a slight improvement on the spindle polish. In case the spindles are hardened with the kolsterization process, the spindels show a matte surface, because the spindle polishing took place before the kolsterization process.

All **ViscoTwin** Pump Housings are hardened with a DURALOY treatment. The inside surface of the pump housing is always matte.



The general build of all **ViscoTwin** pumps also fulfills OSHA guidelines.



### 1.4.2 Pump Face Options



**Processtec** is always on the lookout for new ways to innovate products in our Industry, and so we are proud to announce the **NPSH Optimized Pump Face**. It was designed to transition pumped product more efficiently and gently between the pump face and the pump housing. This design helps in many ways: it keeps the product whole and intact, it eliminates cavitation, and gives the customer more options for piping configurations.

The **NPSH Optimized Pump Face** is designed to increase the efficiency of the pump face during either suction or discharge. During suction, the product has to transition from the cross-sectional area of a 4" OD tube (or smaller) to a cross-sectional area of the pump housing. By the mass flow rate equation and Bernoulli's equation, respectively:

$$\dot{m} = \rho VA = \text{constant} \qquad P_1 + \frac{\rho}{2} V_1^2 = P_2 + \frac{\rho}{2} V_2^2$$

The above equations imply that:  $P_1 * V_1 = P_2 * V_2$

That is, that as the product goes from the smaller inlet to the larger pump housing, the velocity decreases thus the pressure increases. This increased pressure results in a higher NPSHa, thus increasing the pump's capabilities. The **NPSH Optimized Pump Face** also comes with a G1" sanitary port to add a pressure sensor to see the process in action.

Another factor considered in the NPSH design is smooth flow transition. Sudden changes in diameter rapidly increase the Reynolds number of the flow, which can create turbulent flow that will both decrease the pump efficiency and could damage sensitive product. The NPSH pump face addresses these concerns by using a diverging nozzle to expand the flow evenly, avoiding sharp corners and sudden changes to the flow characteristics.



The **Dual Port Pump Face** uses the same principle as the NPSH pump face. This configuration allows for two lines to conjoin at the pump which reduces piping system complexity, while maintaining the efficiency of the NPSH standard pump face.



There is also an **Eco Pump Face**. This is an economic option pumping less viscous or more robust product that can withstand the rapid pressure changes and turbulent flows addressed in the NPSH pump face.

Both the **NPSH Optimized** and **Dual Port Pump Faces** are standardized on 4"OD and a Tri-Clamp connection. Several other size options and process connection options exist but will require longer delivery times. These available options are outlined in the tables below.

PORT SIZE OPTIONS					
OD2.5"	OD3" (Std.)	OD4"	DN65	DN80	DN100

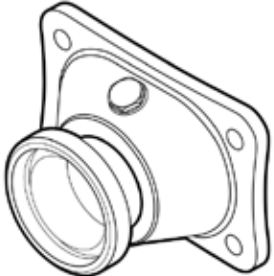
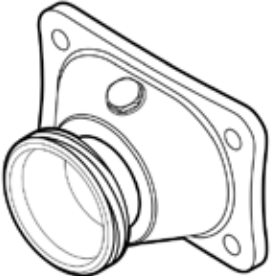
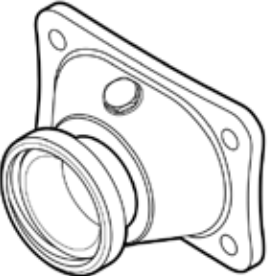
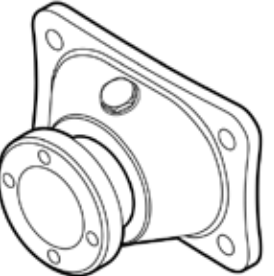
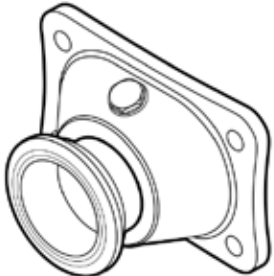
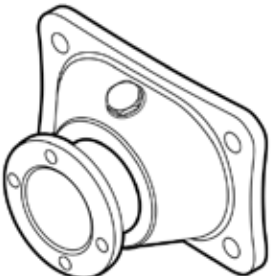
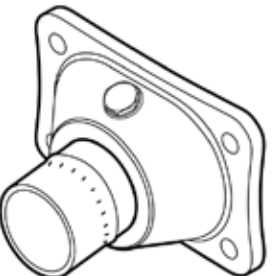
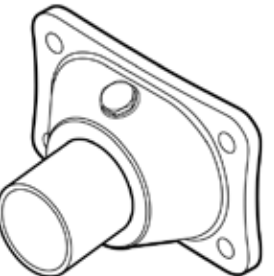
PROCESS CONNECTION OPTIONS			
 <p><b>Tri Clamp</b> (Standard)</p>	 <p><b>DIN 11851</b></p>	 <p><b>DIN 11864-1</b> (Screwed Union)</p>	 <p><b>DIN 11864-2</b> (Flange Union)</p>
 <p><b>DIN 11864-3</b> (Clamp Union, Feral Collar Side)</p>	 <p><b>Varivent Flange</b></p>	 <p><b>Butt Weld</b></p>	 <p><b>Short Pipe</b></p>

**NOTE:** Processtec supplies the Non O-ring / Collar side; the mated O-ring Groove side & clamps are not included with the **ViscoTwin** Pump.

### 1.4.3 Pump Housing Options

#### Flow Direction

The **ViscoTwin G8+, NG** has two general flow directions: Face in -> Housing out (FH) and Housing in -> Face out (HF)

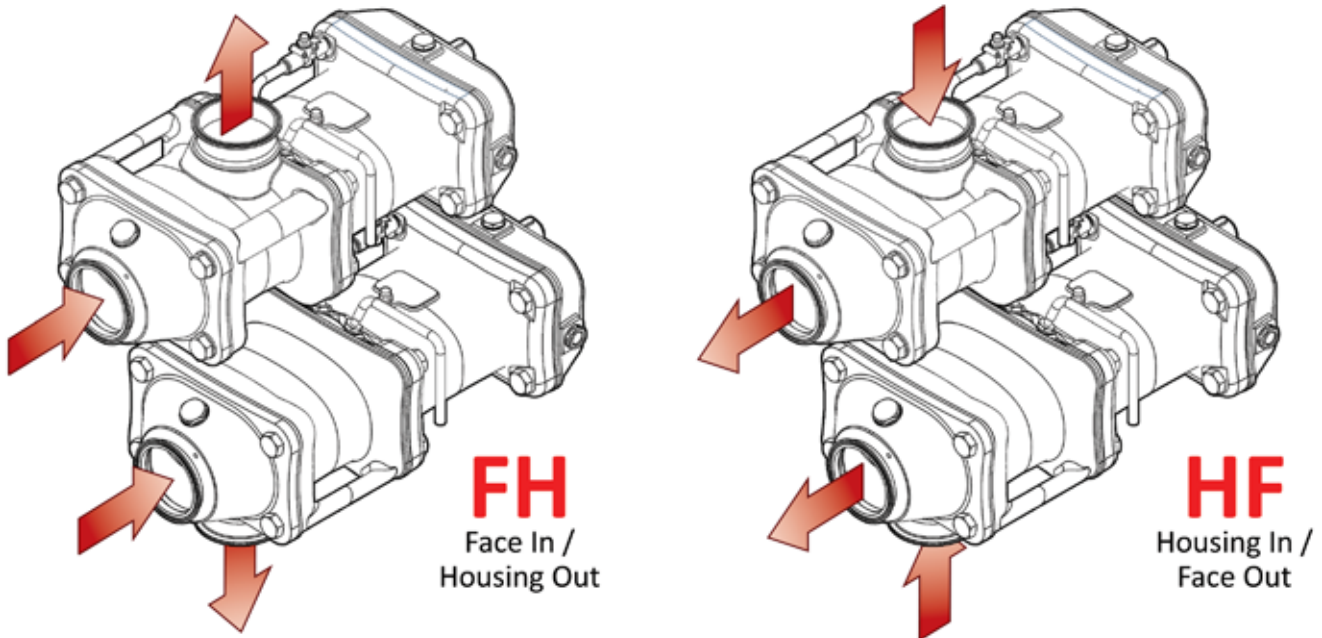

It is preferred to drag the product along the bottom of the housing which requires the shafts to spin “outwards”.

#### **Spindle arrangement for shafts turning “Outwards”:**

- Housing arrangement “FH” -> Spindle arrangement “V”
- Housing arrangement “HF” -> Spindle arrangement “A”
- Outwards turning shafts require the PIN arrangement “3”

#### **Spindle arrangement for shafts turning “Inwards”:**

- Housing arrangement “FH” -> Spindle arrangement “A”
- Housing arrangement “HF” -> Spindle arrangement “V”
- Inwards turning shafts require the PIN arrangement “1”

The most common arrangement for **ViscoTwin** pumps is arrangement FHO3V (see page 102).

**Port Direction**

The ViscoTwin G8+, NG also has two general port directions: Discharge to Top, and Discharge to Bottom.

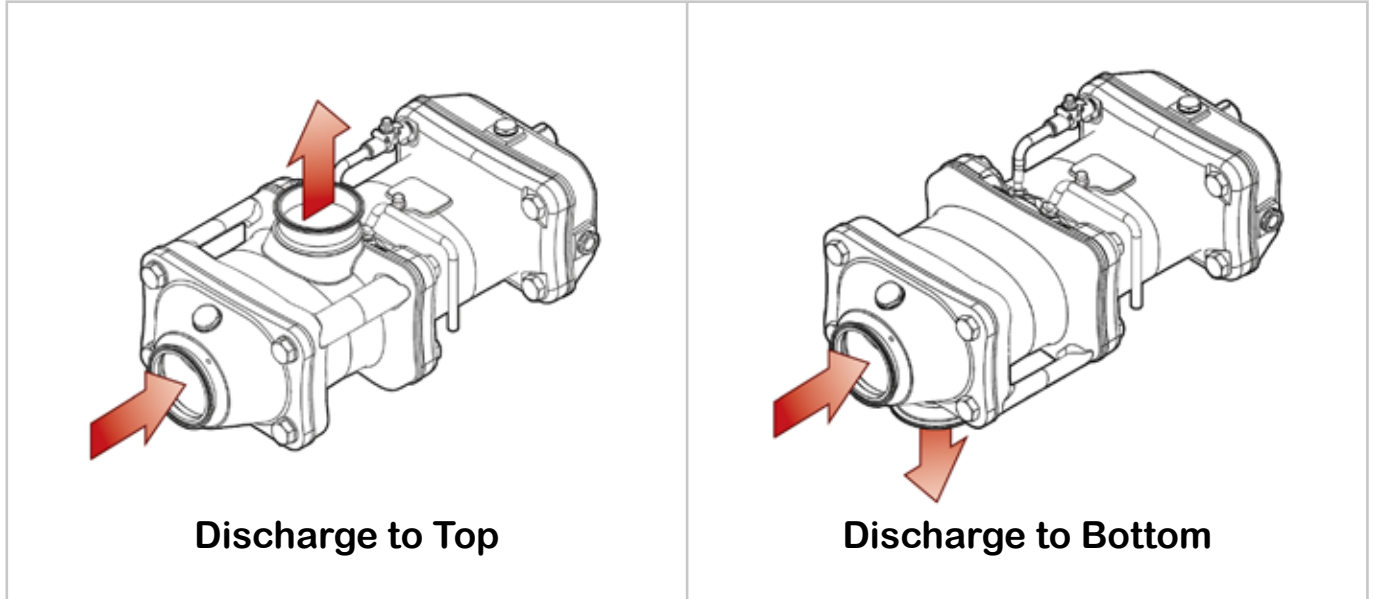

**1.4.4 Elastomer Options**

**Elastomer Selection Table**

	<b>MAX. TEMP</b>	<b>MAX. FAT</b>	<b>TEMP / STRESS</b>
<b>EPDM</b>	140° C	10%	28 bar
<b>FKM</b>	120° C	100%	28 bar
<b>V70SW</b>	200° C	100%	40 bar
<b>PERLAST</b>	200° C	100%	50 bar



**1.4.5 Spindle Options**

Three different spindle pitches are available for each **ViscoTwin** pump size. Each individual spindle pitch itself has the following options:

- Standard EHEDG polish
- Standard 3A polish
- Hardened EHEDG polish
- Hardened 3A polish
- Hardened tapered EHEDG polish
- Hardened tapered 3A polish

Smaller spindle pitches are used to create high discharge pressures, especially with product at viscosities below 2000 cps, at the cost of limiting the flow rate. Larger spindle pitches can be used for high viscous product at medium discharge pressure, and/or high flowrates of low viscous media like CIP at lower differential pressures.

For product with specific particulate sizes, the spindle pitch will determine the minimum pump size. For example, if the particulate requires a cross section of 1", then the pump would need to be a Model 104.53 or Model 130.65.



**Volume per Revolution**

SIZE	SCREW PITCH	VOLUME PER REVOLUTION		PARTICULATE SIZE	
		METRIC	US STANDARD	METRIC	US STANDARD
<b>ViscoTwin 104 G8+, NG</b>	<b>27 mm</b>	0.163 Liter	0.043 Gal	13.5 mm	1/2"
	<b>36 mm</b>	0.217 Liter	0.057 Gal	18.0 mm	11/16"
	<b>53 mm</b>	0.320 Liter	0.085 Gal	26.5 mm	1"

Max Pump Head RPM: 3600 rpm.

### **1.4.6 Mechanical Seal Options**

Different mechanical sealing surfaces and elastomers are available for the **ViscoTwin G8+, NG** pumps. Material and design are selected based on application.

For easy handling, the **ViscoTwin 104 G8+, NG** is designed to use a fully pre-assembled cartridge seal to prevent assembly errors and damages to the sealing surfaces.

For a long service life, please follow the operating conditions the mechanical seals are designed for. **Processtec** has mechanical seals for various pressure and temperature requirements available.

### **Design Options**

Mechanical seals for the **ViscoTwin** are categorized as follows:

- Single Acting Mechanical Seals (SAMS)
- Double Acting Mechanical Seals (DAMS)

Available sealing surfaces in the product area:

- Silicon Carbide (SIC)
- Tungsten Carbide knife edge (TC)

Available Elastomers in the product area:

- FKM (standard)
- EPDM for high temperature without fat content
- FFKM (special applications for high temperature, fat content, and stress)

The mechanical seals are designed to withstand a product area pressure of up to 400 psi. High pressure seals can be used when the product area pressure can reach up to 630 psi, however, these seals can only be used in a specially designed **HPHT** (High Pressure, High Temperature) **ViscoTwin**. Please contact **Processtec** for more information on our High-Pressure pumps.



### Single Acting Mechanical Seals (SAMS)

ViscoTwin G8+, NG Pumps with single acting mechanical seals CANNOT run dry. Due to the self draining capability of ViscoTwin G8+, NG Pumps, Processtec does not recommend using single acting mechanical seals for standard applications.



**Sealing Surface:**  
Silicon Carbide (SiC)



### Double Acting Mechanical Seals (DAMS)

ViscoTwin G8+, NG Pumps with double acting mechanical seals can run dry as long as the quench media flows through the seal. The quench media lubricates and cools the sealing surfaces whether there is product in the pump or not.

The quench area is located between the inboard sealing surfaces (product area) and the outboard sealing surfaces (atmosphere). The quench media reduces friction between the rotating sealing surface and the static sealing surface. The quench media, in most cases, is city water, single pass. It can be glycerine or vegetable oil recirculated from a quench tank.



**Sealing Surface:**  
Tungsten Carbide knife edge (TC)

### 1.4.7 Bearing Housing Options

#### Housing Options:

There are two housing options available for the **ViscoTwin** Bearing Housing and Gear Housing. Both have distinct advantages.



**Stainless Steel**



The **Stainless Steel** bearing housing is our standard option. The **Stainless Steel** bearing housing will not show external wear even after many years in operation, and fulfills the highest sanitary standards.

The **Stainless Steel** bearing housing includes:

- 1) The Gear Housing Inspection Port, which allows for:
  - A mounting space for a vibration sensor & oil temperature sensor to continuously monitor pump performance.
  - Easy oil sampling for gear oil quality testing.\*
  - Spindle gapping without needing to remove and replace the gear oil.
- 2) A second Oil Sight Gauge, which allows for:
  - Oil level inspection from either side of the pump.
  - Easier gear oil visual inspection (particulates in the oil, discoloration, etc.)

*\*oil sample testing kits can be ordered at: [info@processtec.com](mailto:info@processtec.com).*



**Powder Coated**

The **Powder Coated** bearing housing is an economic solution made from cast iron. The powder coating is resilient to external weathering, however some wear can show over time.

### **Bearing Options**

The **ViscoTwin** pump bearing housing is designed to address various forces impacting the pump shafts, which are dependent on flow direction and discharge pressure.

Each shaft is supported by 4 angular ball bearings and one set needle bearing. The needle bearings support the shaft against radial forces in the front. The 4 angular ball bearings support the shaft against axial and radial forces in the back.

The axial forces limit the bearing's lifespan based on  $P = F / A$ , where:

P = differential pressure

F = Axial Force on the Shaft

A = Spindle Surface

For more details, please consult Section 6.4 "Maximizing Bearing Lifespan" on page 115.

ViscoTwin bearing housings are configured based on pressure rating and flow direction as follows:

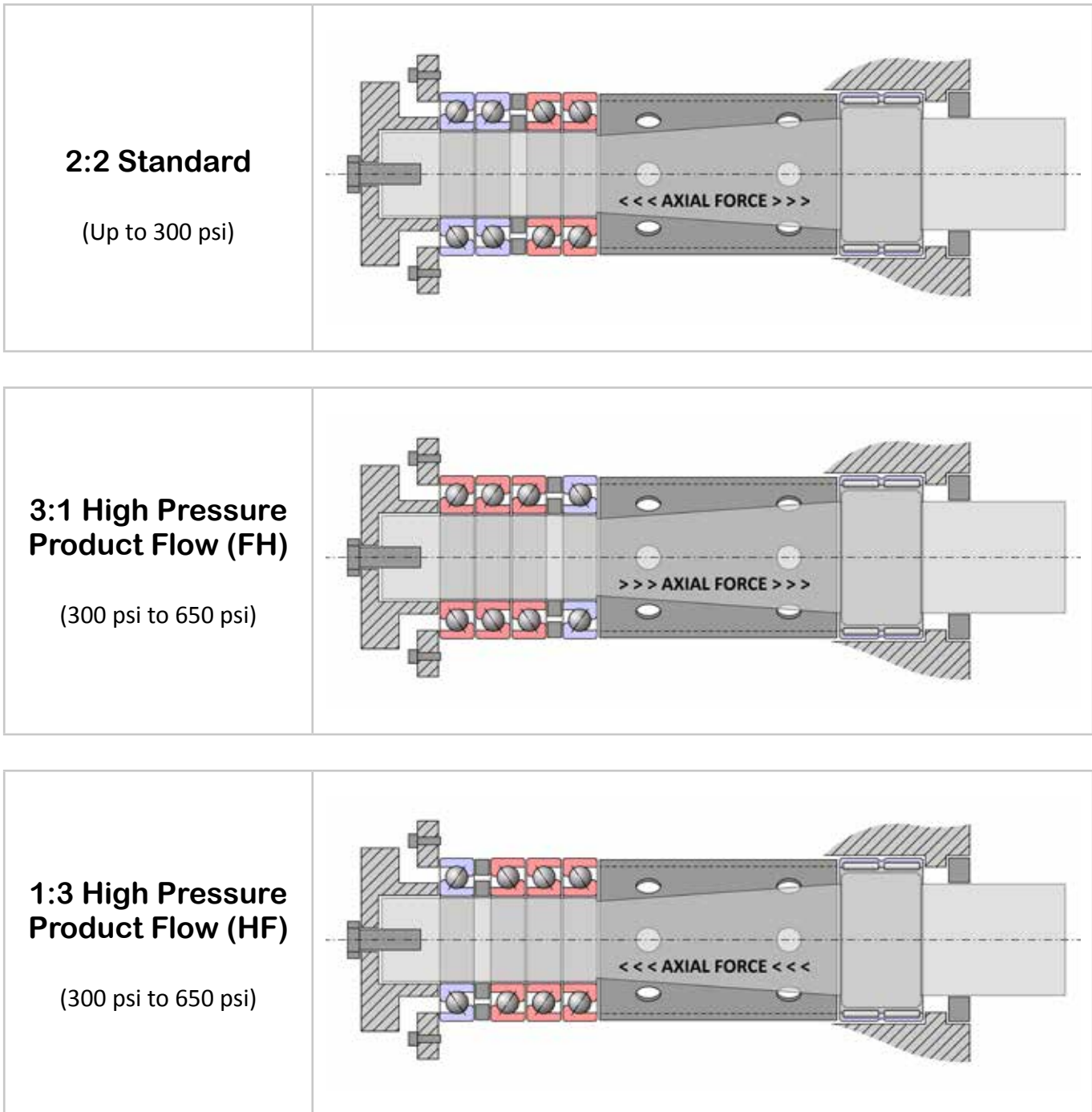

**1.4.8 Motor Options**

For **ViscoTwin** pump motors are optimized to deliver max torque in the 300 - 1200 rpm range at the lowest performance requirement to save cost & complexity. Above 1200 rpms, the **ViscoTwin** pump motor can be used to boost CIP & water, as low viscous media doesn't require high torque. In order to use the motor at higher rpm's, the VFD must be set to allow spin over 60 Hz. Most modern motors from reputable manufacturers can handle the 3600 rpm's, as the shaft & bearings from 4-pole + motors are typically the same as their 2-pole counterparts.

**Sample with 7.5kW (10hp) Motor**

DESCRIPTION	SPEED @ 50Hz	TORQUE @ 50Hz	SPEED @ 60Hz	TORQUE @ 60Hz
2-Pole Motor	2900 rpm	25 Nm/18 lb-ft	3500 rpm	20 Nm/15 lb-ft
4-Pole Motor	1450 rpm	49 Nm/36 lb-ft	1750 rpm	41 Nm/30 lb-ft
6-Pole Motor	965 rpm	74 Nm/55 lb-ft	1166 rpm	61 Nm/45 lb-ft
8-Pole Motor	725 rpm	99 Nm/73 lb-ft	875 rpm	82 Nm/60 lb-ft

**Gearmotors**

Gearmotors are selected when higher torque is needed at lower power & CIP boosting isn't required.

The general limit on gearboxes for overspeeding is 1.5x to 2x to nominal speed.

The generic rule of thumb is:

Metric:  $(Kw \times 9549) = RPM \times Torque \text{ in Nm}$

Imperial:  $(HP \times 5252) = RPM \times Torque \text{ in lb-ft.}$

The torque value of an electric motor is approximately flat between 30 Hz to 60 Hz. Above 60 Hz, the formulas above apply. Below 30 Hz, the loss in torque is very minimal.

**1.4.9 Frame Options**

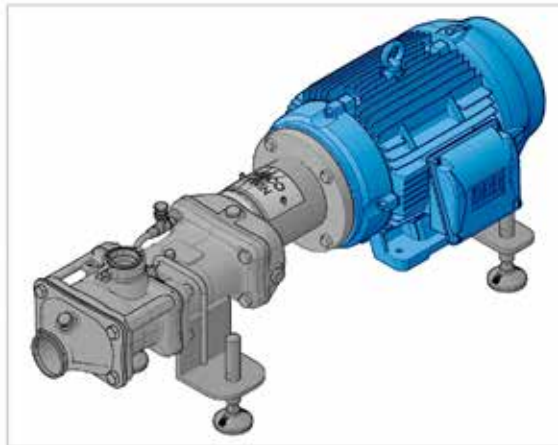

**Frame #1** Frameless (w/Four Legs)

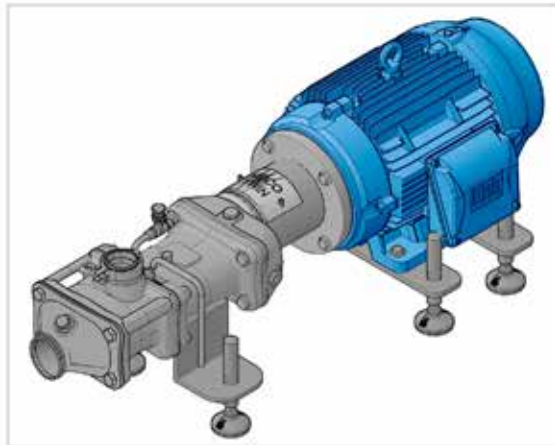

**Frame #2** Frameless (w/Six Legs)

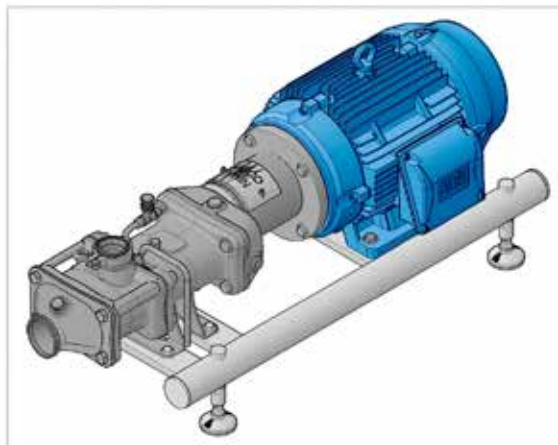

**Frame #3** Heavy Duty Frame



**Frame #4** Service Rail



**Frame #5** Caster Mount



**Frame #6** On Wheels



**1.5 Performance Tables**

The ViscoTwin pump sizing is dependant on the following factors:

- Viscosity of the pumped media
- Required Flowrate
- Required differential pressure (NPSH Optimized discharge pressure)

In the food industry it is very common to have several different set points for various products with various viscosities. Also, the pump is often used for self propelling CIP and needs to speed up in order to meet the desired CIP flowrate of 1.8 m/sec (5 ft/sec) for appropriate line cleaning.

**1.5.1 Sizing Chart**

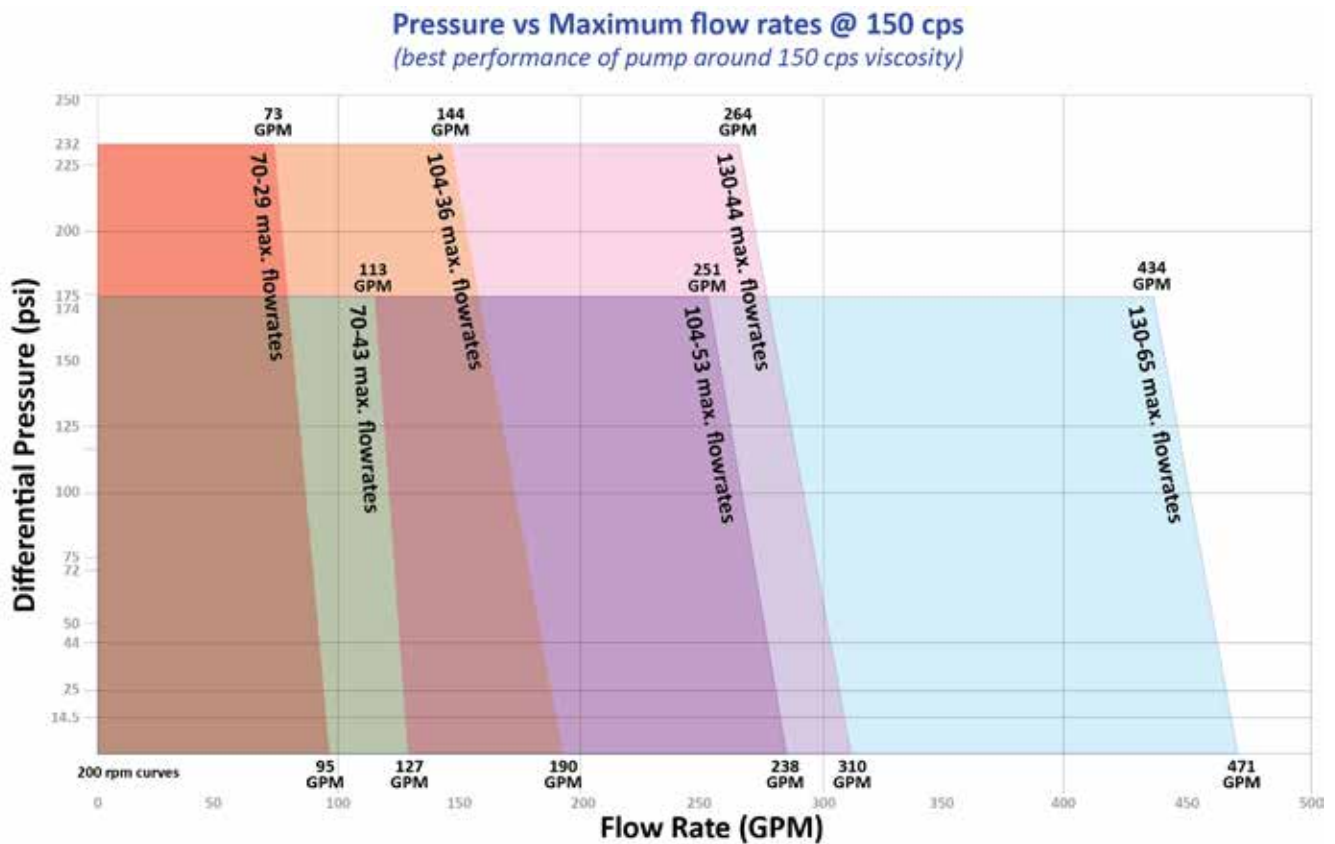

The pump sizing is best accomplished with a proprietary sizing software. For the engineer without access to a sizing program, we created some sizing tables that are ready for download.

The Sizing Tables can be viewed and/or downloaded from the **Processtec** website:

<https://processtec.com/sizing-us-standard.html>



To use the Sizing Charts, follow these steps:

- STEP 1)** Find the field that comes closest to the viscosity and pressure range
- STEP 2)** Find the closest Flow Rate in GPM
- STEP 3)** Determine the RPM on the Pump Shaft
- STEP 4)** Specify the Motor

Performance with 50 cp at 44 psi							
Flow rate	NPSHR	2-Pole	Hz	4-Pole	Hz	6-Pole	Hz
265.2 GPM	14.1 ft	25.0hp	61.7 Hz	25.0hp	123.4 Hz	40.0hp	187.8 Hz
257.3 GPM	13.8 ft	25.0hp	60.0 Hz	20.0hp	120.0 Hz	30.0hp	182.6 Hz
218.0 GPM	11.8 ft	20.0hp	51.4 Hz	15.0hp	102.9 Hz	20.0hp	156.5 Hz
178.7 GPM	9.8 ft	20.0hp	42.9 Hz	10.0hp	85.7 Hz	15.0hp	130.4 Hz
147.2 GPM	8.5 ft	20.0hp	36.0 Hz	10.0hp	72.0 Hz	10.0hp	109.6 Hz
115.7 GPM	7.5 ft	15.0hp	29.1 Hz	7.5hp	58.3 Hz	5.0hp	88.7 Hz
84.3 GPM	6.6 ft	15.0hp	22.3 Hz	7.5hp	44.6 Hz	5.0hp	67.8 Hz
52.8 GPM	5.9 ft	15.0hp	15.4 Hz	7.5hp	30.9 Hz	5.0hp	47.0 Hz
21.4 GPM	5.2 ft	15.0hp	8.6 Hz	7.5hp	17.1 Hz	5.0hp	26.1 Hz
5.6 GPM	4.9 ft	10.0hp	5.1 Hz	5.0hp	10.3 Hz	5.0hp	15.7 Hz

**PROCESSTEC** Sizing table ViscoTwin 104-53 US-Standard  
Motor 2-pole: 3500rpm@60Hz | Motor 4-pole: 1750rpm@60Hz | Motor 6-pole: 1150rpm@60Hz

**ViscoTwin** the most versatile constant pump

Speed (rpm/Hz)	Performance with 1 cp at 14.5 psi				Performance with 1 cp at 44 psi				Performance with 1 cp at 72 psi			
	Flow rate	NPSHR	2-Pole	4-Pole	Flow rate	NPSHR	2-Pole	4-Pole	Flow rate	NPSHR	2-Pole	4-Pole
3500 rpm	382.8 GPM	12.8 ft	7.0hp	61.7 Hz	265.2 GPM	14.1 ft	25.0hp	61.7 Hz	217.1 GPM	14.8 ft	20.0hp	61.7 Hz
3500 rpm	368.9 GPM	12.8 ft	7.0hp	60.0 Hz	257.3 GPM	13.8 ft	25.0hp	60.0 Hz	213.2 GPM	14.8 ft	20.0hp	60.0 Hz
3500 rpm	355.0 GPM	12.8 ft	7.0hp	58.3 Hz	243.4 GPM	13.8 ft	25.0hp	58.3 Hz	209.3 GPM	14.8 ft	20.0hp	58.3 Hz
3500 rpm	341.1 GPM	12.8 ft	7.0hp	56.6 Hz	229.5 GPM	13.8 ft	25.0hp	56.6 Hz	205.4 GPM	14.8 ft	20.0hp	56.6 Hz
3500 rpm	327.2 GPM	12.8 ft	7.0hp	54.9 Hz	215.6 GPM	13.8 ft	25.0hp	54.9 Hz	201.5 GPM	14.8 ft	20.0hp	54.9 Hz
3500 rpm	313.3 GPM	12.8 ft	7.0hp	53.2 Hz	201.7 GPM	13.8 ft	25.0hp	53.2 Hz	197.6 GPM	14.8 ft	20.0hp	53.2 Hz
3500 rpm	299.4 GPM	12.8 ft	7.0hp	51.5 Hz	187.8 GPM	13.8 ft	25.0hp	51.5 Hz	193.7 GPM	14.8 ft	20.0hp	51.5 Hz
3500 rpm	285.5 GPM	12.8 ft	7.0hp	49.8 Hz	173.9 GPM	13.8 ft	25.0hp	49.8 Hz	189.8 GPM	14.8 ft	20.0hp	49.8 Hz
3500 rpm	271.6 GPM	12.8 ft	7.0hp	48.1 Hz	160.0 GPM	13.8 ft	25.0hp	48.1 Hz	185.9 GPM	14.8 ft	20.0hp	48.1 Hz
3500 rpm	257.7 GPM	12.8 ft	7.0hp	46.4 Hz	146.1 GPM	13.8 ft	25.0hp	46.4 Hz	182.0 GPM	14.8 ft	20.0hp	46.4 Hz
3500 rpm	243.8 GPM	12.8 ft	7.0hp	44.7 Hz	132.2 GPM	13.8 ft	25.0hp	44.7 Hz	178.1 GPM	14.8 ft	20.0hp	44.7 Hz
3500 rpm	229.9 GPM	12.8 ft	7.0hp	43.0 Hz	118.3 GPM	13.8 ft	25.0hp	43.0 Hz	174.2 GPM	14.8 ft	20.0hp	43.0 Hz
3500 rpm	216.0 GPM	12.8 ft	7.0hp	41.3 Hz	104.4 GPM	13.8 ft	25.0hp	41.3 Hz	170.3 GPM	14.8 ft	20.0hp	41.3 Hz
3500 rpm	202.1 GPM	12.8 ft	7.0hp	39.6 Hz	90.5 GPM	13.8 ft	25.0hp	39.6 Hz	166.4 GPM	14.8 ft	20.0hp	39.6 Hz
3500 rpm	188.2 GPM	12.8 ft	7.0hp	37.9 Hz	76.6 GPM	13.8 ft	25.0hp	37.9 Hz	162.5 GPM	14.8 ft	20.0hp	37.9 Hz
3500 rpm	174.3 GPM	12.8 ft	7.0hp	36.2 Hz	62.7 GPM	13.8 ft	25.0hp	36.2 Hz	158.6 GPM	14.8 ft	20.0hp	36.2 Hz
3500 rpm	160.4 GPM	12.8 ft	7.0hp	34.5 Hz	48.8 GPM	13.8 ft	25.0hp	34.5 Hz	154.7 GPM	14.8 ft	20.0hp	34.5 Hz
3500 rpm	146.5 GPM	12.8 ft	7.0hp	32.8 Hz	34.9 GPM	13.8 ft	25.0hp	32.8 Hz	150.8 GPM	14.8 ft	20.0hp	32.8 Hz
3500 rpm	132.6 GPM	12.8 ft	7.0hp	31.1 Hz	21.0 GPM	13.8 ft	25.0hp	31.1 Hz	146.9 GPM	14.8 ft	20.0hp	31.1 Hz
3500 rpm	118.7 GPM	12.8 ft	7.0hp	29.4 Hz	7.1 GPM	13.8 ft	25.0hp	29.4 Hz	143.0 GPM	14.8 ft	20.0hp	29.4 Hz
3500 rpm	104.8 GPM	12.8 ft	7.0hp	27.7 Hz	0.0 GPM	13.8 ft	25.0hp	27.7 Hz	139.1 GPM	14.8 ft	20.0hp	27.7 Hz
3500 rpm	90.9 GPM	12.8 ft	7.0hp	26.0 Hz	0.0 GPM	13.8 ft	25.0hp	26.0 Hz	135.2 GPM	14.8 ft	20.0hp	26.0 Hz
3500 rpm	77.0 GPM	12.8 ft	7.0hp	24.3 Hz	0.0 GPM	13.8 ft	25.0hp	24.3 Hz	131.3 GPM	14.8 ft	20.0hp	24.3 Hz
3500 rpm	63.1 GPM	12.8 ft	7.0hp	22.6 Hz	0.0 GPM	13.8 ft	25.0hp	22.6 Hz	127.4 GPM	14.8 ft	20.0hp	22.6 Hz
3500 rpm	49.2 GPM	12.8 ft	7.0hp	20.9 Hz	0.0 GPM	13.8 ft	25.0hp	20.9 Hz	123.5 GPM	14.8 ft	20.0hp	20.9 Hz
3500 rpm	35.3 GPM	12.8 ft	7.0hp	19.2 Hz	0.0 GPM	13.8 ft	25.0hp	19.2 Hz	119.6 GPM	14.8 ft	20.0hp	19.2 Hz
3500 rpm	21.4 GPM	12.8 ft	7.0hp	17.5 Hz	0.0 GPM	13.8 ft	25.0hp	17.5 Hz	115.7 GPM	14.8 ft	20.0hp	17.5 Hz
3500 rpm	7.5 GPM	12.8 ft	7.0hp	15.8 Hz	0.0 GPM	13.8 ft	25.0hp	15.8 Hz	111.8 GPM	14.8 ft	20.0hp	15.8 Hz

Sizing Tables:



 <b>ViscoTwin</b> 70-29	 <b>ViscoTwin</b> 104-36	 <b>ViscoTwin</b> 130-44
 <b>ViscoTwin</b> 70-43	 <b>ViscoTwin</b> 104-53	 <b>ViscoTwin</b> 130-65

1.5.2 Water Curves

These Water Curve Performance Charts show CIP & waterflush and also products with Viscosity 1.

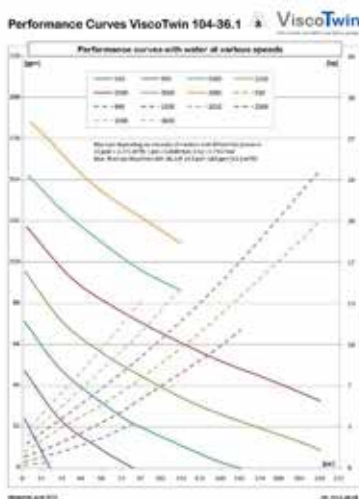

Water Curve Performance Charts in **US STANDARD** can be viewed and/or downloaded from the **Processtec** website here:  
<https://processtec.com/water-curves-us-standard.html>



Water Curve Performance Charts in **METRIC** can be viewed and/or downloaded from the **Processtec** website here:  
<https://processtec.com/sizing-us-standard.html>



*This page intentionally left blank.*

## 2. INSTALLATION

### 2.1 Unpacking

Check the contents and all wrapping when unpacking the pump. Inspect the pump carefully for any damage that may have occurred during shipping. Immediately report any damage to the carrier. Keep the protective caps over the pump inlet and outlet in place until the pump is installed.

### 2.2 Inspection / Technical Documentation

Inspect the pump for visible shipping damages on pump head, lantern with coupling, motor, and frame. Locate the technical documentation that is shipped with the pump including:

- 0. Equipment Receiving Protocol
- 00. Pump Shipping Documents Template
  
- 1. Configuration Key
- 2. Equipment Commissioning Protocol
  
- 3.1 3.1 Pump Housing Photo
- 3.2 3.2 Spindle Photo
- 3.3 3.3 Bearing Housing Photo
  
- 4. Spindle and Pin Configuration
- 5. **ViscoTwin** Manual (104 G8+, NG)
- 6. Spare Parts Catalog (104 G8+, NG)
- 7. Customer Recommended Tools Catalog

Use these documents to ensure the pump is shipped as ordered & store these documents for future reference. All pumps are labeled with a sticker showing a QR code, the pump model, a serial number, and a Component ID identifying the building plan of the pump at **Processtec**.

### 2.3 Hoisting and Transportation

#### LIFTING WITH A PALETTE JACK OR FORKLIFT FORKS

A Palette Jack can be used to lift the **ViscoTwin** Assembly, if it is already on a flat surface. Slide the forks of the palette jack underneath the lift points, taking care to make sure that the Assembly Footing Tabs are being supported sufficiently.

Forklift forks can also be used to lift the **ViscoTwin** Assembly by sliding underneath the footing on the Motor and Bearing Housings. Make sure that the **ViscoTwin** Assembly is completely supported and that both forks are contacting the **ViscoTwin** Assembly before lifting.



#### WRAPPING A LIFTING STRAP AROUND THE LANTERN

The **ViscoTwin** Assembly, when bolted together properly, is strong enough to be hoisted via a strap around the Safety Lantern.

Using the properly-rated lifting strap, wrap it underneath the lantern.

Move one end of the looped strap through the other end, and then cinch down the strap around the Safety Lantern.



### LIFTING HOOK INSTALLATION

The Lifting Hook can be attached to the Pump Housing, and is designed to lift the **ViscoTwin** Pump Head while maintaining a center of balance.

Be sure that the clamps are firmly in place on the Pump Housing before proceeding.



### STRAP PLACEMENT FOR HOISTING THE MOTOR WITH A FORKLIFT LIFTING HOIST

Forklift forks with a Forklift Lifting Hoist can also be used for lifting the **ViscoTwin** Motor off of the Frame once detached, in conjunction with a hoisting strap. Make sure that the **ViscoTwin** Motor is completely supported and that the Forklift Lifting Hoist is firmly secured to both forks before lifting.



### PUMP ASSEMBLY HOISTED IN MID-AIR

When the **ViscoTwin** Assembly is hoisted in midair via the lifting strap, the position of the strap on the lantern will determine whether the assembly stays level or not.

You can lift the entire assembly a few inches to see if the position of the lifting strap is centered on the assembly, supporting it evenly, then lower it back down to re-adjust the position of the lifting strap on the Safety Lantern.

A proper position on the Safety Lantern will allow you to hoist the assembly in a level position.



## 2.4 Installation

The following points need to be considered while installing the pump in the system:

1. All pump frames are delivered with height adjustable feet to accommodate sloped floors for drainage. The pump should always be level for proper lubrication of all the bearings. To level the pump, adjust the height-adjustable feet individually (see red arrows) until the pump is level.

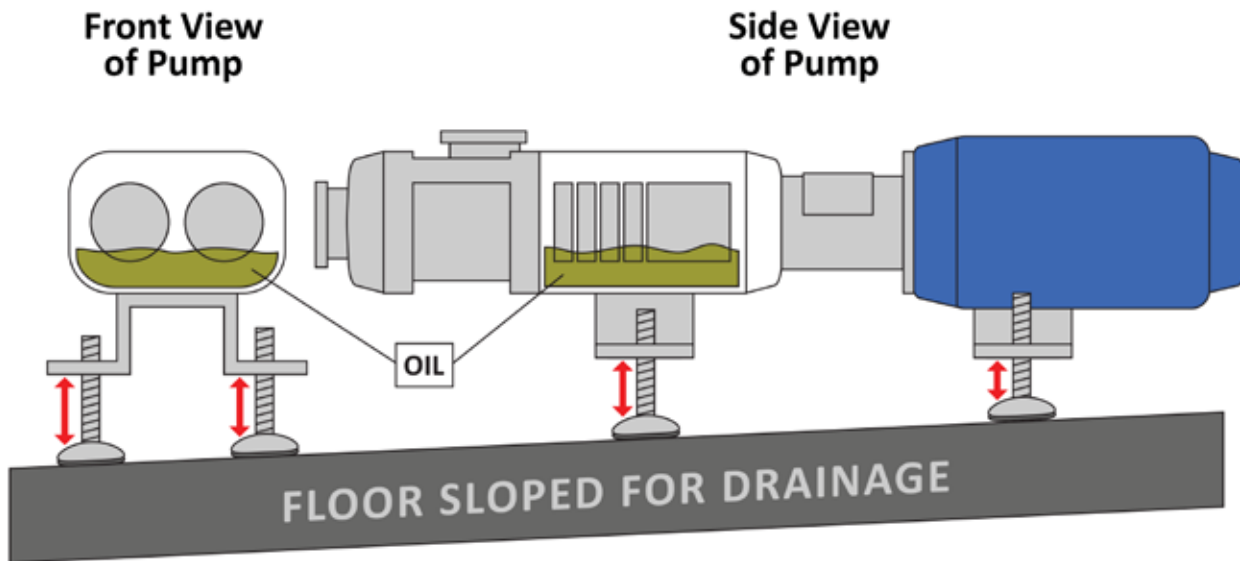

2. No excess forces should be exerted on the pump from piping systems, platforms etc.
3. Ensure good access to the oil sight glass at the gear housing for regular inspection from operators and maintenance personnel.
4. Ensure good access to the bolts (Pos. 1016) to easily remove the Pump Housing with a extended torque wrench for sanitary inspection.
5. Ensure that the whole pump can be easily accessed for preventive pump maintenance at the Pump Housing and the Gear Housing for oil change. If this can not be arranged, ensure that the pump can be easily removed from the operating location with a palette jack, forklift or rollers, into a location that allows accessing all parts of the pump.
6. Connect the Seal Water if the pump is equipped with a double seal that requires seal water. It is recommended that the seal water automatically starts and stops with the pump to save water.
7. Ensure that the electric wiring can easily be disconnected for maintenance and is not a safety hazard or dirt trap.



## 2.5 Piping Before and After the Pump

Sizing the correct upstream and downstream piping including valves and fittings is very involved and depends on the experience of the application engineer. **Processtec** developed a sizing program that accounts for kV values of common sanitary valves and pipe fittings at various sizes and port arrangements. The program requires the input of a valid apparent viscosity value. Please consult **Processtec** engineering if you need support to verify your piping arrangement.



### 2.5.1 Upstream Piping

The upstream piping of the pump requires the utmost attention. The NPSH available from the system (NPSHa) needs to be higher (higher absolute pressure) than the NPSH required (NPSHr) by the pump (lower absolute pressure).

The NPSHa must be less than the NPSHr or cavitation occurs. The pumped media creates vaporized bubble that immediately collapse & damage both the product & the pump.

The **ViscoTwin** has excellent suction capabilities and will maintain it throughout its life cycle if operated per design. Since **ViscoTwin** pumps can be used with very viscous media, any flow restrictions preventing the product from arriving at the pump suction nozzle at the desired flowrate must be removed. If the pump is sped up faster than the product can enter the pump, the pump cavitates, and will damage the pumped media, and the pump itself.

#### Typical installation errors that create cavitation:

- Product has a higher apparent viscosity than anticipated. Typically, colder product results in a higher apparent viscosity.
- The upstream pipe is undersized in diameter as well as the associated valves, fittings, elbows, and tees.
- Too many restricting devices in the suction line like valves, tees, elbows, or other pipe restrictions.
- The suction pipe is too long.
- Particulates in the product are caught in valves, restricting the flow

### 2.5.2 Downstream Piping

The max discharge pressure on standard **ViscoTwin** models depends on the pump configuration and the pumped media. Pump configurations with the largest possible spindle pitch max out between 12 bar and 14 bar. Pumps equipped with the smaller spindle pitches (consult the options table) have a max discharge pressure of 25 bar (362 psi). The max temperature with standard elastomers is 130° C (266° F).

If the desired discharge pressure can not be met with the **ViscoTwin 104 G8+, NG** due to spindle pitch restriction, **Processtec** recommends using the **ViscoTwin 130 G8+, NG** with a smaller spindle pitch.

For higher discharge pressures and temperatures, please consult **Processtec** Engineering to customize a durable pump setup for pressures up to 45 bar (692 psi) and 200° C (390° F). In Chapter 6 "Geek's Corner" in this manual (see page 112), we detail options for pressures, temperatures, and other demanding applications. Our customized pumps are engineered for the longevity of the bearings, elastomers, mechanical seals, and spindles. We can calculate the expected bearing life with optimized configurations for temperatures up to 180° C.

### 2.5.3 Piping Before and After the Pump

The **ViscoTwin** pump operates like a hybrid pump between a centrifugal pump and an absolute positive displacement pump, primarily due to slip between the left and right hand spindles and between the spindles and the pump housing. Due to this fact bypasses are generally not needed, allowing for a deadzone-free piping arrangement. **ViscoTwin** pumps can be installed in series without a bypass if proper engineering principles are applied.

In case the pump is cleaned with an external CIP supply pump for a higher flowrate than the **ViscoTwin** is designed for, the pushing CIP solution will propel the **ViscoTwin** pump at a relatively low flow restriction, making a bypass obsolete. The pump will start to spin, even if it is not started. No damage will occur if correct engineering principles are applied.

## 2.6 Mechanical Seal Connection

To maximize the service life of the mechanical seals and ensure a cool and clean area behind the inboard sealing surface, **ViscoTwin** pumps are pre-piped for pass through seal water with a manual needle valve to restrict the flow at the inlet. The inlet piping is connected with a 1/4" compression fitting. The bypass piping and discharge piping is piped in 3/8" round tubing, avoiding corners for easy passage of eventual residues or debris. The recommended flowrate is 0.1 GPM.

**Processtec** offers options to save water usage with:

- A pneumatic or magnetic valve to start the seal water only if necessary
- A small flowmeter (1/4") to confirm the flow of seal water
- A quench tank installation (see Section 6.3 "Quench Design for Recirculating Fluids in Mechanical Seals" on page 114)

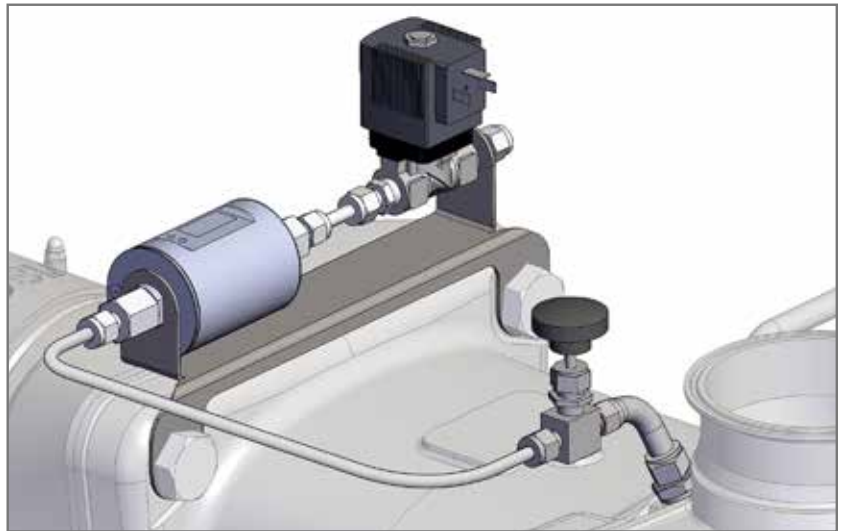

**2.7 Pre-Installation of Seal Water for Dual Acting Mechanical Seal**

When using city water (from the tap), it is advisable to run an in-line filter, to prevent any possible debris or sediment from entering the pump.

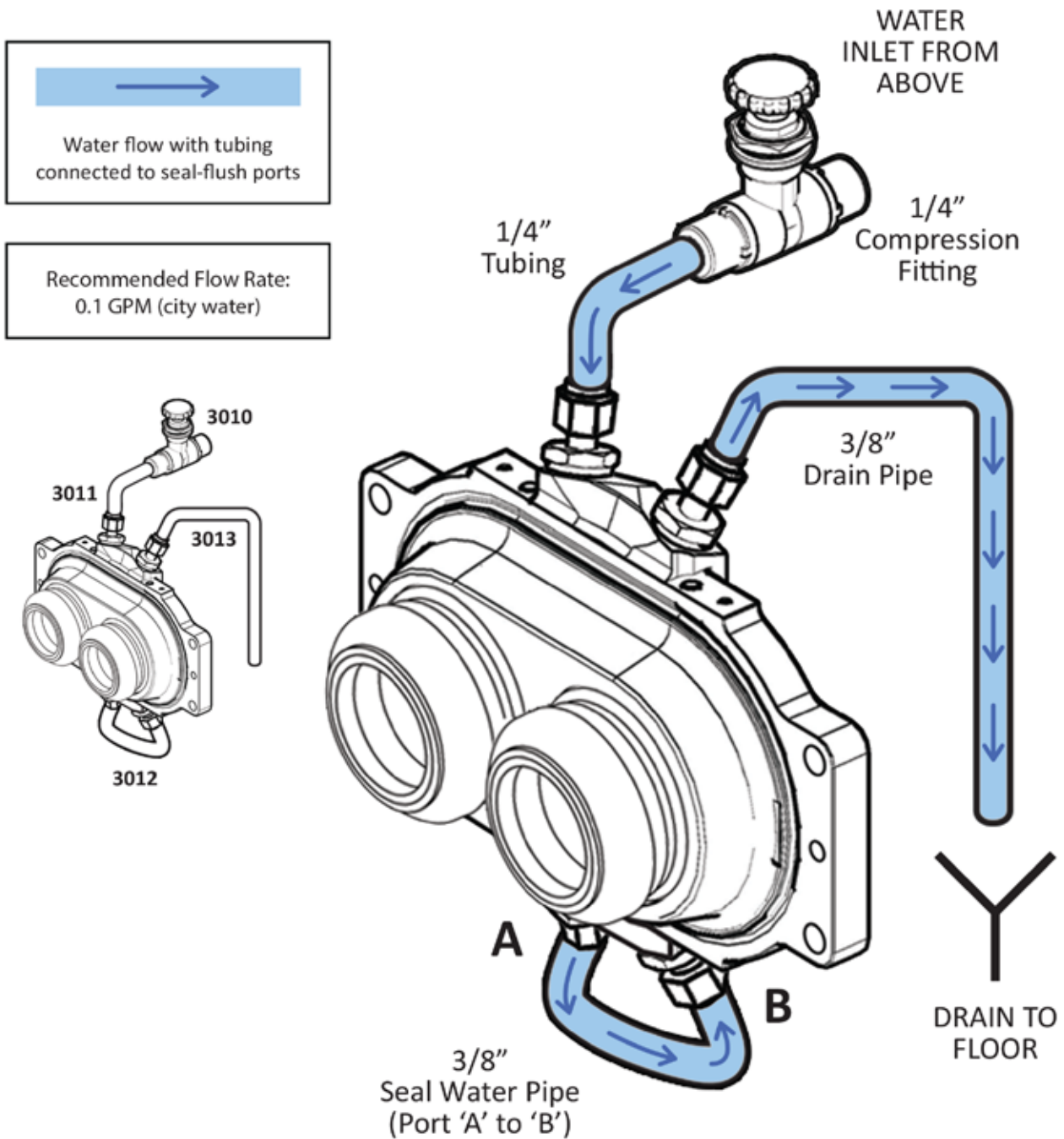

## 2.8 Electrical Installation

**Processtec** on default selects 3-phase AC motors that meet country specific installation requirements. For the US and Canada we select NEMA frame motors. For Mexico, Europe and Australia we select IEC motors that meet country spec.

Other motor standards are available upon request. It is up to the client to follow the country specific guidelines for electrical installations.

*This page intentionally left blank.*

## **3. OPERATION**

### **3.1 Pump Startup**

Before starting up the **ViscoTwin 104** pump after the installation, or after system changes upstream occur, it is important that no debris or foreign material can enter the pump head. Because of the tight clearance between the spindles and the pump housing, any debris entering the pump housing can cause severe damage to pump housing and spindles. After any system modification upstream occur, the piping needs to be severely flushed. Before the pipe flushing begins, the pump suction line needs to be disconnected from the pump face or pump housing, and directed to the floor so no debris can be flushed into the pump housing.

### **3.2 Soft Starting the Pump**

It is recommended to gradually ramp up the pump speed, as opposed to performing a hard start. Twin Screw pumps are mostly used in heavy duty applications with viscous media, often with particulates, and changing viscosity based on product properties and fluctuating temperatures. Most food products have non-Newtonian fluid behavior and are shear thinning.

When starting up slow, the viscous product is forced into motion. Friction along the pipe walls is imparted onto the product. The imparted friction on the shear thinning product lowers the apparent viscosity momentarily. The lower apparent viscosity results in a lower overall pressure drop in the system. This is especially helpful in the suction line of the pump. Lower apparent viscosity increases the NPSH available (NPSHa).

The soft start allows the pump to ramp up speed over a period of 15 to 30 seconds in a controlled manner while reading the motor amps from the VFD into the PLC. The shear thinning effect is sensed with the decreasing amps indicated by the VFD.

### 3.3 Avoiding Pump Cavitation

When the pump cavitates due to a flowrate that is too high for the suction line size and the product viscosity, the flowrate needs to be lowered. The NPSH Optimized Pump Face from **Processtec** has a built in pressure gauge port to install a vacuum sensor to indicate the NPSH directly at the pump head. With the feedback signal from the vacuum gauge, the pump can be safely operated at min NPSH required, resulting in its max speed for the given setup without damaging the product and pump.



### 3.4 Pumping Sensitive Products

Sensitive product like macaroni & cheese sauce or cooked potato pieces can easily be pumped without creating damage to it if the pump housing and the spindles are correctly sized. However, if the pump suction is too strong, sensitive product contents like macaroni can be stretched and break apart. In this case, the flowrate must be lowered as a momentary solution. For a long term solution, the pump suction system must be modified by increasing the suction line size and removing flow restrictions like valves, Tee's etc. The NPSH at the pump face should read between 2 and 4 feet, depending on product.

Note that -14.5 psi (- 1 bar) is absolute vacuum on this planet. If the suction line is undersized, hence the NPSH is too low or almost zero, no pumping system exists to provide the desired performance.



### 3.5 Material Selection for Sealing Surfaces

**ViscoTwin** pumps are often operated with viscous and sticky media in a stop and go application. The pump re-start can stress the seal faces at the engagement pins and break brittle seal face materials such as Silicon Carbide. In this case, a sustainable solution would be to use Tungsten Carbide knife edge seal faces.

### 3.6 Pumping Product with Large Particulates

When the application requires pumping product with large particulates, the pump housing needs to be configured accordingly:

- **Considering Spindle Size** - Large enough spindle pitches: A spindle pitch 65 means that the cross section between the flanks is 32.5mm = 1-1/4 inches.
- **Considering Port Size** - Large enough port size: The most critical opening is in the seal area towards the pump housing. Bigger is better.
- **The Ideal RPM Range** - Slow enough spindle speed: between 300 and 800 rpm.

### 3.7 High Pressure Systems

In case a differential pressure above 300 psi is required for extended operating times, **Processtec** offers system upgrades up to 600 psi and 375° F. This is limited to selected spindle pitches, therefore limiting max flowrate and min product viscosity.

**3.8 CIP / COP Solution**

CIP stands for Clean In Place, which is the process in which a pump is cleaned in its current location. It is standard for most pumps in the Industry. The **ViscoTwin** can be CIP'd in a variety of different setups:

**Self-Propelled Cleaning**

The pump is used as a CIP return pump. This is mostly the case when a pump is installed as a tank discharge pump.

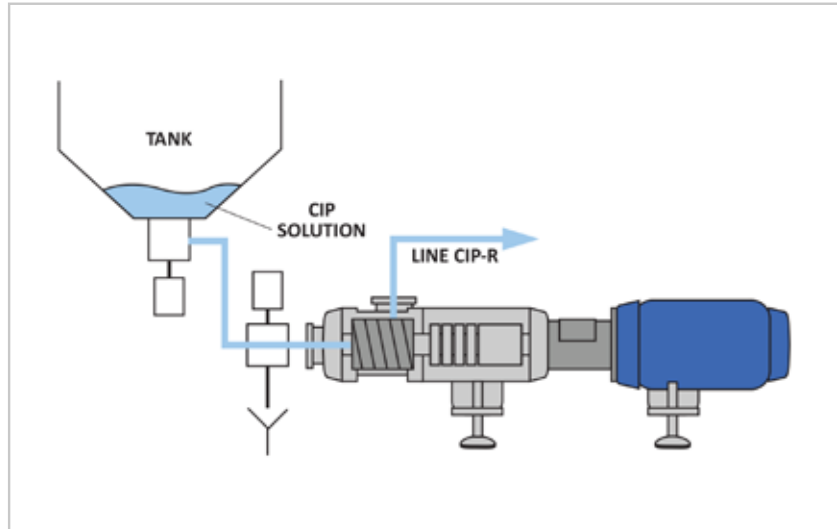

**Inline Cleaning**

The pump does not need to propel the CIP solution and is part of the cleaned pipe line. A dedicated CIP pump upstream is propelling the CIP solution. In this case there is no need for a bypass around the pump housing to achieve a high flow rate in the upstream and downstream pipe.

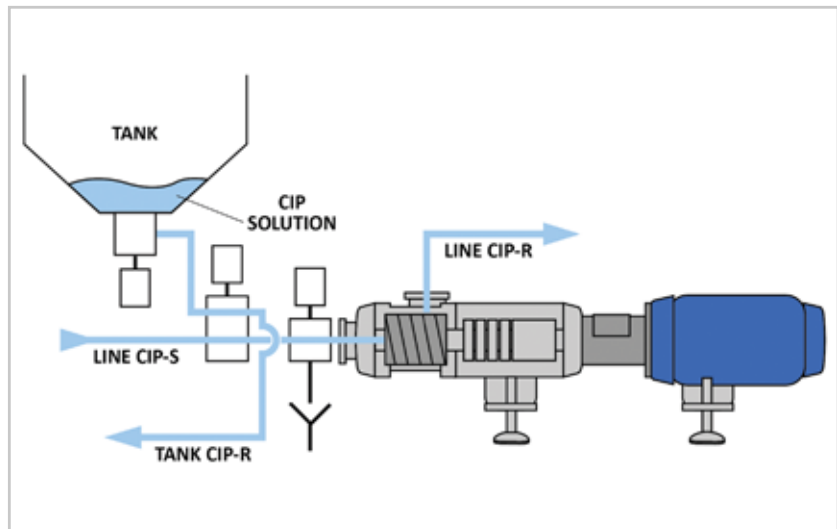

**ViscoTwin** pumps operating with watery solution are like a hybrid between a centrifugal and positive displacement pump.

**ViscoTwin** pumps have sufficient slip for CIP solution to be pushed through the pump head without creating large pressure drops. The spindles will start spinning by themselves if not operated during in-line cleaning. To protect the outboard seal faces from overheating, the seal water supply should be activated during CIP.

### **3.9 Visual Inspection**

We recommend daily observation of the pump as described in Subsection 4.2.1 "Maintenance Level 1 (ML-1)" on page 43.

### **3.10 Available Elastomer Options**

If excessive wear and tear on elastomers in the Pump Housing is observed, **Processtec** offers various elastomer options to address demanding applications based on temperature, oil/fat content, and permeable stress. We offer EPDM, FKM, V70SW and Perlast elastomers to address various oil content/temperature/stress combinations.

For more information, check out the Elastomer Options Chart in Subection 1.4.4 "Elastomer Options" on page 10.

**3.11 Leakage**

Leakage is the primary concern for mechanical sealing. Mechanical Seal Leakage depends on many factors, most of which are listed in the table below. Leakage is generally significantly higher during initial startup when the elastomers are dry and need to be broken-in to allow proper sealing. Afterwards, the elastomers should seal completely during normal operations.

**Possible Causes of Mechanical Seal Failures or Leakage**

FAILURES OR LEAKAGE	POSSIBLE CAUSES
Dry-Running	Thermal shock from lack of seal water
Mechanical Shock	Stator installed at the wrong angle
Wear on the sliding surfaces	Deposits on the sliding surfaces
Corrosion on the sliding surfaces or springs	Dirt, oil, or grease on the sliding surfaces
Axial misalignment	Improper installation
Extreme vibrations	Excess loads from pipe connections
Caked-on product on the product-side of the seal (DAMS)	Damaged/destroyed atmospheric-side of the seal (DAMS)
The seal faces will glue together	Long storage time and the screws have not been hand-turned as instructed

Slow leaks are a primary concern as the small amount of liquid tends to evaporate into the atmosphere. This is unacceptable with toxic or environmentally harmful liquids. The standard for such cases is a Double Acting Mechanical Seal with a quench medium to flush out and contain dangerous product media in a separate, closed system.

Due to legal regulations, leaks must be constantly monitored to protect the environment. For maintenance or cleaning cycles, it is recommended to monitor flushing loss using either a visual flow measurement or a back-pressure sensor. **Processtec** advises regularly inspecting and/or replacing the visible O-rings on the mechanical seal cartridge during maintenance and inspection intervals or repairs.

### 3.12 Scratches in the Pump Housing

If the spindles or the pump housing show scratches, this indicates that the spindles touch each other or touch the pump housing. The following should be investigated first:

**A) Pump configuration with PIN position:**

Each **ViscoTwin** Pump Housing is configured based on flow direction and kind of pumped product. The standard configuration is **FHO3V**:

- F: Face In
- H: Housing Out
- O: Spindles turning outwards
- 3: Pin Position 3
- V: Spindle Arrangement "V"

For more information, please see Section 5.5 "Pump Housing Configuration" on page 100.

**B) The spindles are not correctly gapped.** The clearances between the spindles show that the flights on one side touch each other. Please consult Subsection 4.5.8 "Proper Gapping of Pump" on page 68.

**C) The spindles touch the housing at the pump face end when A) and B) are verified and correct.** The clearance between spindle tip and housing is too small for the viscosity of the pumped product and the associated rpm. This issue can be addressed with tapered spindles.

*This page intentionally left blank.*

## 4. MAINTENANCE

### 4.1 Maintenance Preparation

#### 4.1.1 General Movie: HOW THE PUMP WORKS



#### QR Code

Please use any cell phone or tablet with a QR reader application to start the movie.



This movie can be found at

<http://processtec.com/videos/ViscoTwin-Mechanics-2.mp4>

#### 4.1.2 Introduction to Web Page

In the **ViscoTwin** Overview section on the main **Processtec** webpage (<http://processtec.com/viscotwin-overview.html>), you will find a variety of content that is helpful for pump maintenance, including links to various Maintenance Movies, General Documents and Manuals, and other useful information. Use the QR Code to the right to access this section on the **Processtec** web page.



On that Overview page, you will find the Downloads section (<https://processtec.com/viscotwin-g8-downloads.html>), which contains a directory of folders containing the following technical information:



- Explosion Drawings G8+, NG
- Manuals G8 (104, 130)
- Pin Configurations G8+, NG
- Spare Parts Catalog G8+, NG
- Tool List G8+, NG
- Torque Tables G8+, NG

### **4.1.3 Risk Assessment for Pump Maintenance**

#### **1) Risk of Pump Falling**

There are certain precautions which must be taken when working around **ViscoTwin** pumps. Failure to adhere to the proper guidelines for transporting or lifting of the pump can result in personal injury, or damage to the pump itself.

When moving or lifting the pump, please keep the following in mind:

- Pumps and related parts are heavy, and must be moved using the proper steps as outlined in Section 2.3 "Hoisting & Transportation" on page 24.
- When moving the pump, you must observe the center of gravity and also the maximum weight of the load.
- Only use suitable slings with sufficient load-bearing capacity.
- Only use proper hoisting attachment points to lift the motor.
- Never stand underneath the motor while it is being lifted or suspended.
- Never stand between the suspended load and a stationary object (such as a wall or floor)
- Keep the surrounding area clear from obstructions, and free from people

#### **2) Metal Splinters due to Sharp Spindle Flights**

This mostly occurs because the spindles touched while in operation. Reasons for touching spindles are failure to correctly install the spindles on the shaft or foreign material entered the pump and scratched the spindles and the pump housing.

#### **3) Pinched Fingers / Cut Fingers**

Pinched fingers occur when the pump is manually moved while the pump housing is removed. Carrying the pump on the spindles is risky because the spindles can turn towards each other.

### **4.1.4 Safety Measures**

**1) LOTO** - Follow factory instructions for LOTO (Lock Out / Tag Out).

**2) Wear Gloves** - To prevent burns and cuts.

**3) Hands-On Training** - Qualified Maintenance Technicians performing **ML-2** tasks need to have hands-on training. They need to become familiar with the pump, the required tools, the supporting documents and charts.



## 4.2 Explaining Maintenance Levels

### 4.2.1 Maintenance Level 1 (ML-1)

**ML-1** is the daily observation of the pump by the operator, which includes the following steps:

#### STEP 1) Checking for Product Leaks

A) Product leaks can occur around the pump housing due to a leaking pipe connection, or a worn and brittle O-ring in the pump housing.

B) In case the seal water is cloudy, the mechanical seal has a leak and needs to be inspected by a maintenance technician.

#### STEP 2) Check for Oil Leaks at the following positions:

A) Both Shaft Seal Rings in front of the Bearing Housing (Pos. 2322).

B) The Shaft Seal Ring in the back of the Gear Housing (Pos. 1010).

C) The Oil Level Sight Gauge at the Gear Housing (Pos. 2360).

D) Both Oil Plugs at the Gear Housing (Pos. 2233).

In case the operator notices oil leaks on the floor, a maintenance technician needs to inspect the pump.

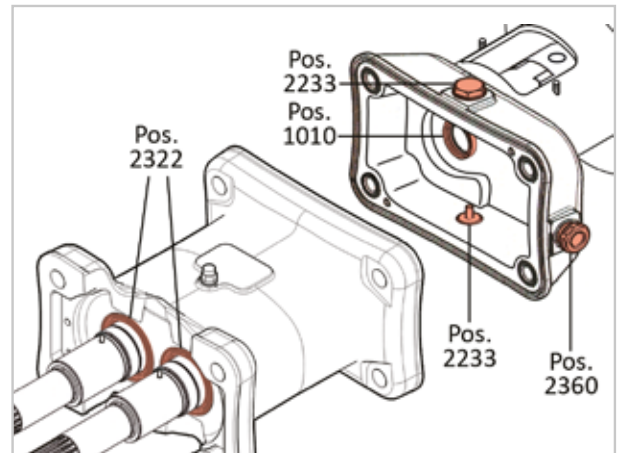

#### STEP 3) Check for Strange Noises

In case unusual noises occur, the pump needs to be stopped. A maintenance technician needs to inspect the pump for:

- A) Foreign material in the pump housing
- B) Damaged mechanical seals
- C) Damaged or mis-aligned motor coupling
- D) Damage at the motor, failing motor bearings

### **4.2.2 Maintenance Level 2 (ML-2)**

**ML-2** is recommended to only be performed by qualified maintenance technicians as defined in Section 1.1 "Safety Notes" on page 1.

#### **STEP 1) Sanitary Inspection**

In order to inspect the product contact area, the pump housing needs to be removed by unthreading the FOUR (4) bolts in Pos. 1016. The spindles, the mechanical seals, the seal housing and the pump housing with pump face can be inspected from every angle.

#### **STEP 2) Oil Inspection/Sampling and/or Oil Change**

A) The first oil change is required after 250 hours. This is known as the break-in period.

B) It is recommended to sample the oil every 3 months after the first oil change and exchange it accordingly with the recommended oil. Based on the humidity of the environment, the oil can degrade more or less quickly depending on amount of starts and stops the pump is exposed to. Repeated start/stopping heats and cools the bearing housing, which sucks in outside air and moisture into the gear housing.

#### **STEP 3) Exchange Mechanical Seal**

Please follow the steps outlined in Subsection 4.4.2 "Complete Pump Disassembly" on page 51.

#### **STEP 4) Gapping the Pump**

In case the spindles touch each other after a pump cleanup because foreign material entered the pump housing, the pump needs to be gapped. Please follow Subsection 4.5.8 "Proper Gapping of Pump" on page 68.

### **4.2.3 Maintenance Level 3 (ML-3)**

**ML-3** is recommended to only be performed by a specialized shop that handles bearing exchange and pump testing like **Processtec**.

#### **STEP 1) Timing**

In very rare cases the pump needs to be timed. Timing is necessary when the gearwheel space is too small for gapping. The gearwheel needs to be moved by one tooth. Timing is always necessary after a bearing exchange.

#### **STEP 2) Bearing Fatigue**

Exchange all bearings with the correct tools only by a specialized shop. For more information on Bearing Fatigue, please see Section 6.4 "Maximizing Bearing Lifespan" on page 115.

**4.3 Material at hand, Required Parts & Tools**

**4.3.1 Recommended Spare Parts**

The recommended spare parts at hand are shown in the explosion drawing in the following positions:

Pos. #	Description
2192	Pump Face O-Ring
2194	Spindle Screw O-Ring
2195	Pump Housing Alignment Pin
1088	Seal Housing O-Ring
2535	Mechanical Seal (Single Acting or Double Acting)
2322	Shaft Sealing Ring (Bearing Housing)
1010	Shaft Sealing Ring (Gear Housing)
2513	O-Ring (BH/GH Large)
2514	O-Ring (BH/GH Small)
2360	Oil Level Sight Gauge
2233	Screw Plug
2249	Coupling Part (Rubber)

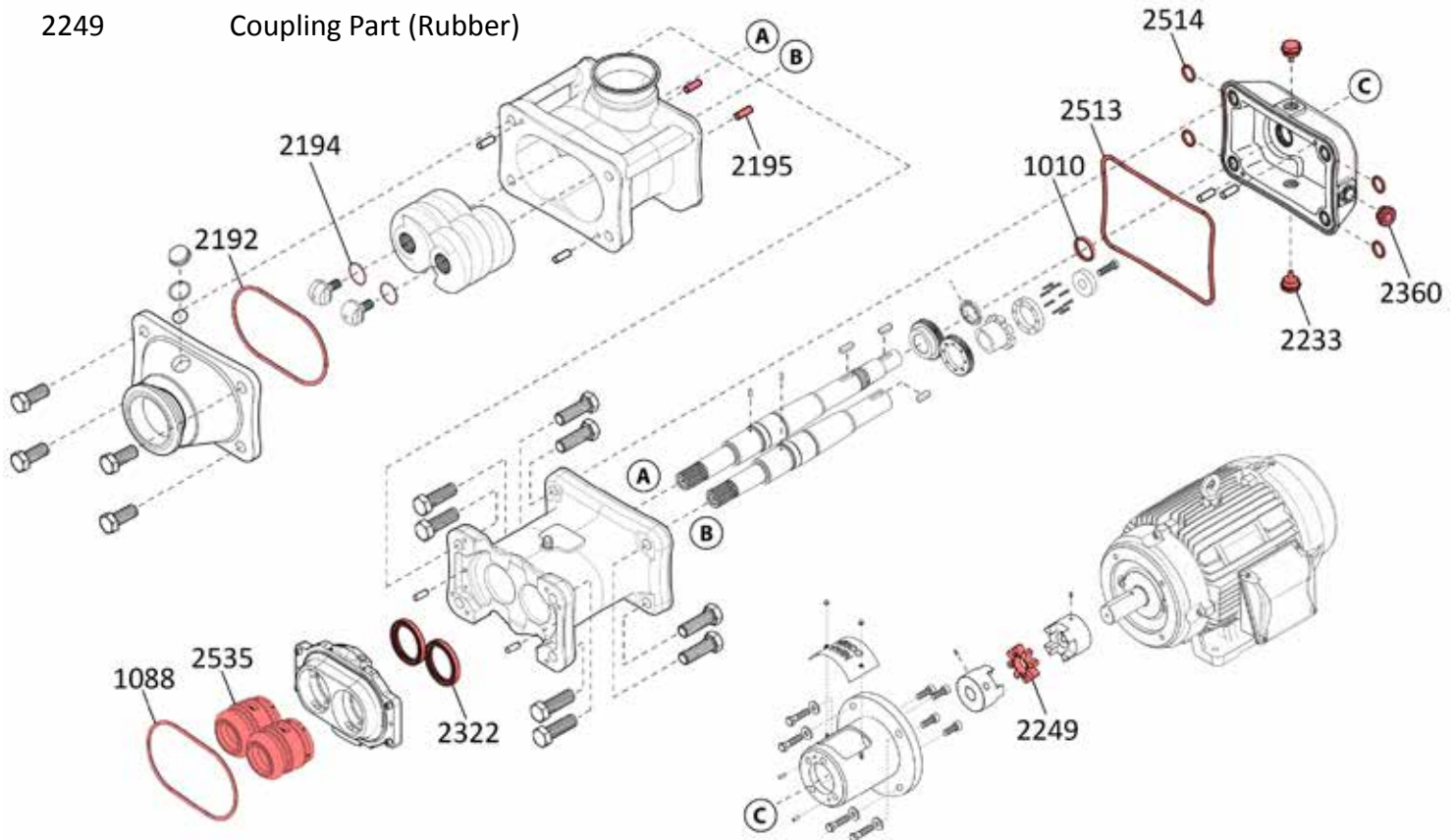

### 4.3.2 Recommended Tools

The recommended tools at hand are Tools for 104 ML-2 use only. (Please see Section 5.1 "Tools" on page 75 for more information)

### 4.3.3 Recommended Oils, Grease

The quality of the bearing oil greatly influences the service life of the pump, especially pumps operating in humid environments with many starts and stops. Please study Section 6.4 "Maximizing Bearing Lifespan" on page 115.

It is important to notice that not all oils can be mixed. Synthetic oils based on Polyglycol have water absorbing properties that greatly increase service life, but cannot be mixed with oils based on Polyalphaolifin.

**Processtec** recommends Klubersynth UH1-6 150 for **ViscoTwin** pumps. It's a foodgrade oil with water absorbing properties. Its viscosity covers a large temperature range. The max temperature is 140° C.

The **ViscoTwin 104** requires 0.7 liter gear oil.

In cold locations like receiving bays, **Processtec** recommends the selection of the lower end viscosity, normally indicated with numbers 68 or 100. For warmer processing environments, we recommend a more viscous oil indicated with numbers 150.

For more information on Oils, please see to Section 5.6 "Oils, Grease & Lubrication Recommended" on page 108.

## 4.4 Maintenance Instructions for ML-2

### 4.4.1 Removing the Pump Housing

Removing the Pump Housing can be done for the following reasons:

- A) Sanitary Inspection
- B) First action in case the pump does not pump product.

Required Tools:

- Socket Hex Nut 24mm
- Torque Wrench (Large) for torques up to 150 Nm

#### STEP 1)

Remove the FOUR (4) Hex Screws (Pos. 1016).

#### STEP 2)

Remove the whole Pump Housing (Pos. 2530) towards the front.

#### STEP 3)

Inspect the product contact surfaces for cleanliness

#### STEP 4)

Inspect the product contact surfaces for scratches and bruises.

#### STEP 5)

Inspect the elastomers for wear and tear, and correct installation.

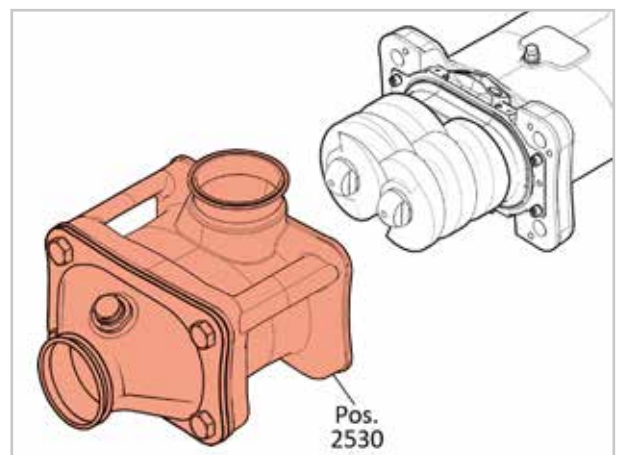
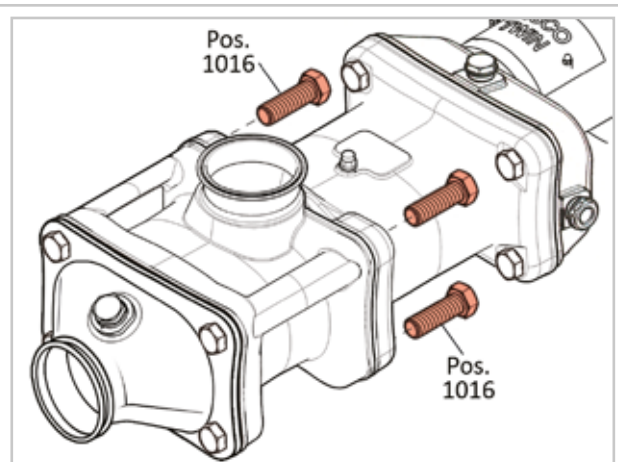

**STEP 6)**

Turn the Spindles with your hands (use gloves) and inspect that the spindles turn freely and do not touch.

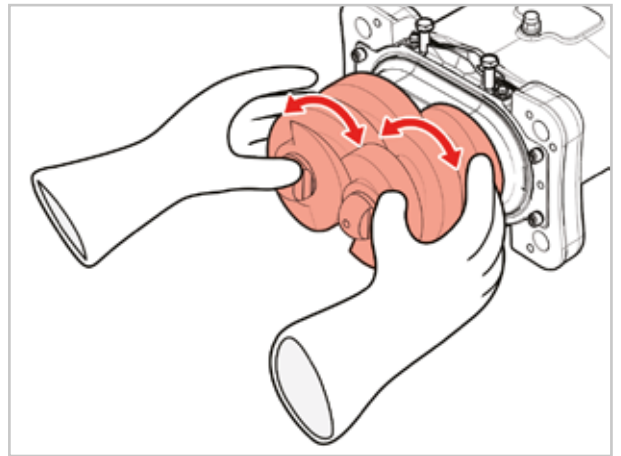

**STEP 7)**

Push the spindles axially to inspect that the shafts are tight, indicating that the bearings are in good condition.

**STEP 8)**

Hold a white sheet of paper underneath the spindles and verify that the spindles do not touch.

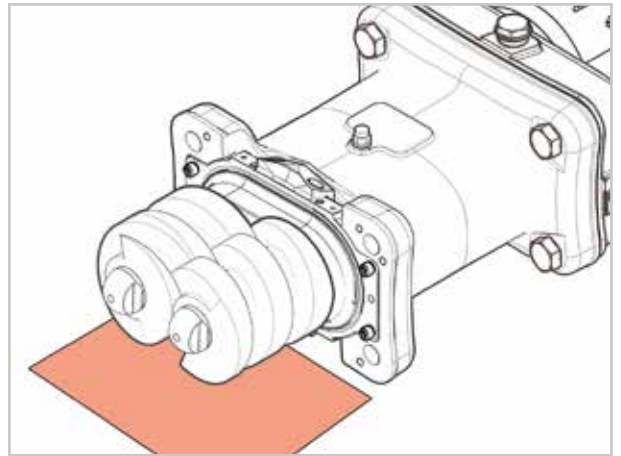

**STEP 9)**

In case of touching or tight gaps, the pump needs to be gapped. This can become necessary if foreign material entered the pump, blocked one of the shafts, and the gearwheel slipped. For more information, please see Subsection 4.5.8 "Proper Gapping of the Pump" on page 68.

**Action Steps for Re-assembly of Pump Housing:**

**STEP 1)**

Slide the Pump Housing (Pos. 2530) back into position. Check that the TWO (2) Pump Housing Alignment Pins (Pos. 2195) are still in place. If you removed the pins, please re-install it as required by your Pump Housing Pin Configuration (Pos 1, 2 or 3).

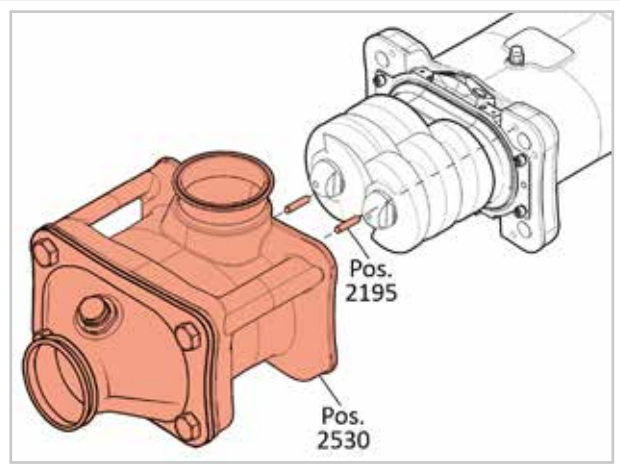

**STEP 2)**

Re-install the FOUR (4) Hex Screws (Pos. 1016) and torque each of them to 150 Nm.

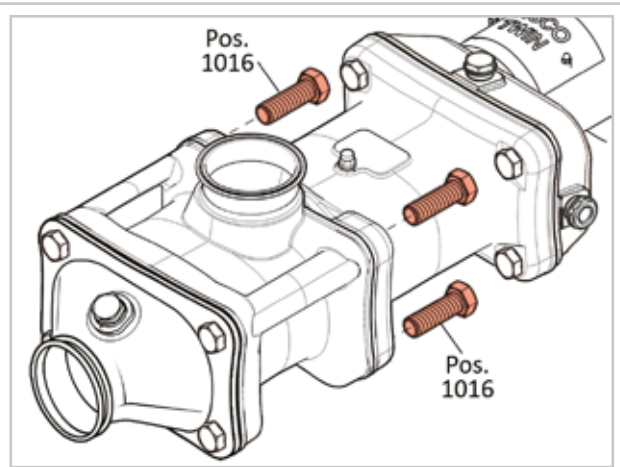



### 4.4.2 Complete Pump Disassembly

Removing the Pump Housing can be done for any one of the following reasons:

- A) Exchange the Mechanical seals
- B) Exchange all elastomers in the product contact surface area.
- C) Exchange the spindles because of wear or reconfiguring the pump
- D) General Pump Inspection

#### Required Tools:

- 5mm Socket Hex Nut (for Pos. 2259)
- 8mm Socket Hex Nut (for Pos. 3002)
- 10mm Socket Hex Nut (for Pos. 2533)
- 24mm Socket Hex Nut (for Pos. 1016 & 2527)
- 30mm Spindle Screw (for Pos. 2180)
- Torque Wrench - Small (1/4" Drive, Capable of Torque ranging from 8 to 15 Nm)
- Torque Wrench - Large (1/2" Drive, Capable of Torque up to 150 Nm)

#### Action steps for complete pump disassembly:

- STEP 1)** Removing the Pump Face
- STEP 2)** Removing the Pump Housing
- STEP 3)** Blocking the Shaft in the Lantern Area
- STEP 4)** Removing the Spindles
- STEP 5)** Removing the Seal Housing
- STEP 6)** Removing both seals from the Seal Housing
- STEP 7)** Inspecting the Pump Parts

#### **STEP 1)**

##### REMOVING THE PUMP FACE

A. Remove the Pump Face (Pos. 2528) by unthreading the FOUR (4) Hex Head Bolts (Pos. 2527). The pump face is still held in place by the Pump Face Alignment Pins (Pos. 2196). You might need a mallet to remove it because it can sit very tight.

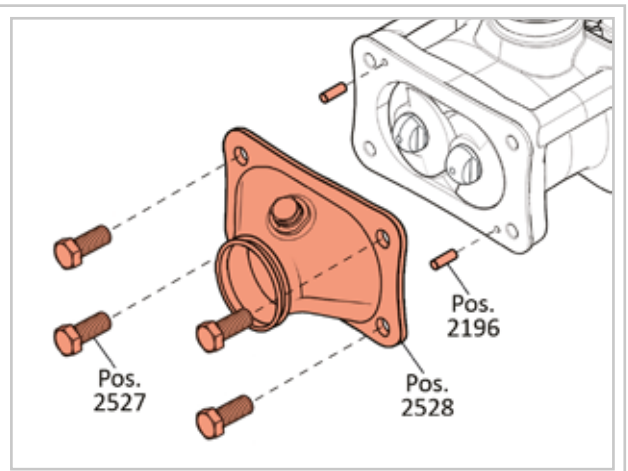

**STEP 2)**

**REMOVING THE PUMP HOUSING**

- A. Remove the FOUR (4) Hex Screws (Pos. 1016).
- B. Remove the whole Pump Housing (Pos. 2530) outwards, away from the Bearing Housing, and off of the spindles.

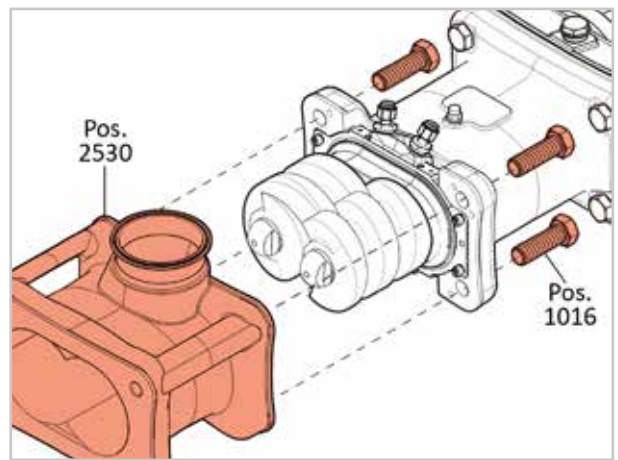

**STEP 3)**

**BLOCKING THE SHAFT IN THE LANTERN AREA**

Blocking the Shaft in the Lantern area prevents the spindles from turning during maintenance and inspection.

- A. Remove both Cap Nuts (Pos. 3002) from the Lantern Safety Guard.
- B. Remove the Lantern Safety Guard (Pos. 3001).
- C. Rotate spindles until the hole on Pump Coupler (Pos. 2247) is facing up.
- D. Insert Shaft Blocking Tool into top of Lantern opening, and guide the peg into the coupler hole, making certain that it is all the way in, and firmly in place. Be sure that the Shaft Blocking Tool also engages in the Lantern Window.

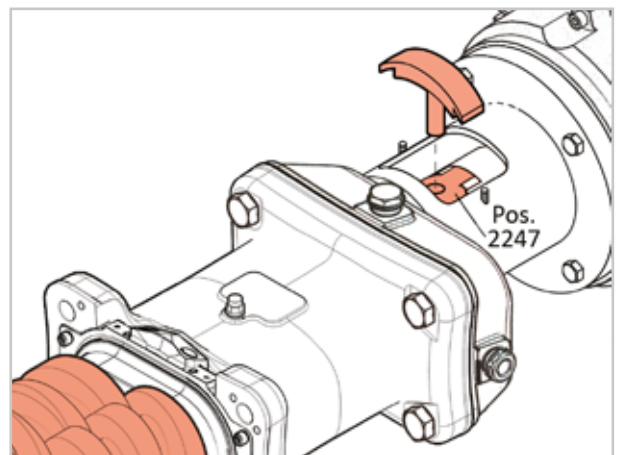
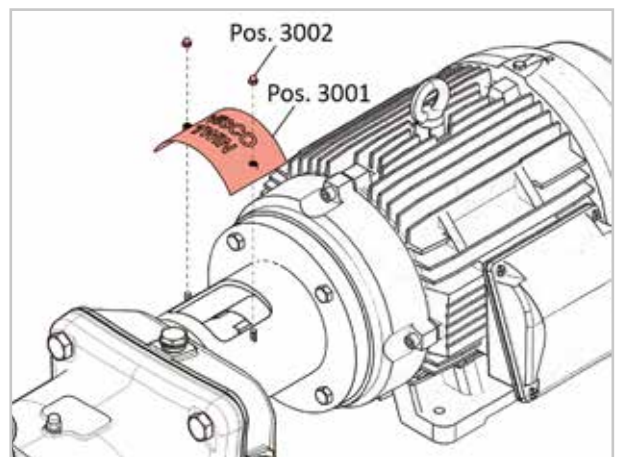

**STEP 4)**

**REMOVING THE SPINDLES**

A. Once the Shaft Blocking Tool is in place, use the Aluminum Spindle Screws Slotted Nut on a torque wrench to remove the Spindle Screws (Pos. 2180) on the drive and driven shafts.

B. In the event that the spindles get stuck, simply use a Rubber Mallet to knock them loose. Hit one side, then the other, alternating until driven loose.

C. **WARNING! DO NOT USE A METAL HAMMER. DOING SO WILL CAUSE DAMAGE!**

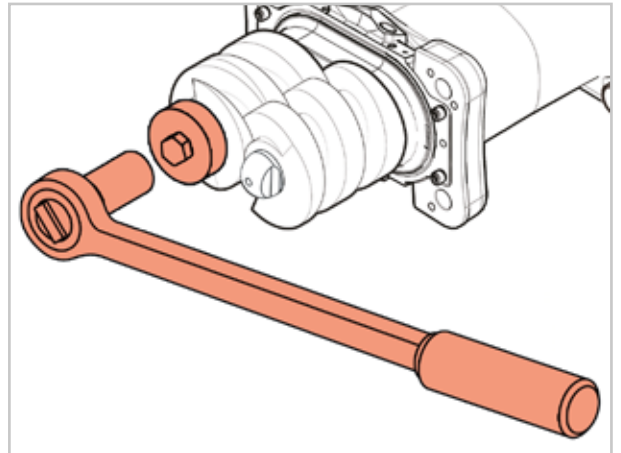

**STEP 5)**

**REMOVING THE SEAL HOUSING**

A. Remove the FOUR (4) Socket Head Cap Screws (Pos. 2259) from the Seal Housing.

B. Remove the Seal Housing (Pos. 2188) that contains the Mechanical Seals (Pos. 2535).

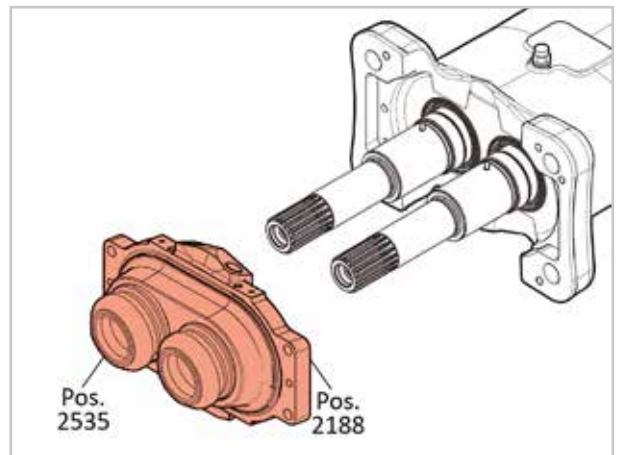
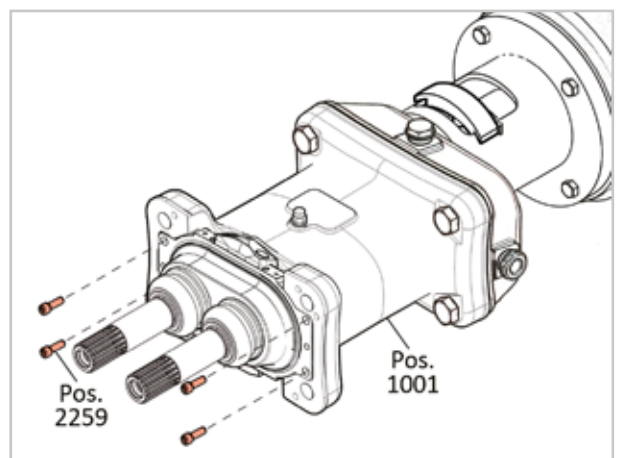

**STEP 6)**

**REMOVING BOTH SEALS FROM THE SEAL HOUSING**

A. Unthread both Hex Head Cap Screws for Mechanical Seal (Pos. 2533).

B. Grip the Seal Housing, with the Bearing Housing Side facing up, and press the old Mechanical Seals downward, towards the Product Side of the Seal Housing. Now, the old Mechanical Seals are removed.

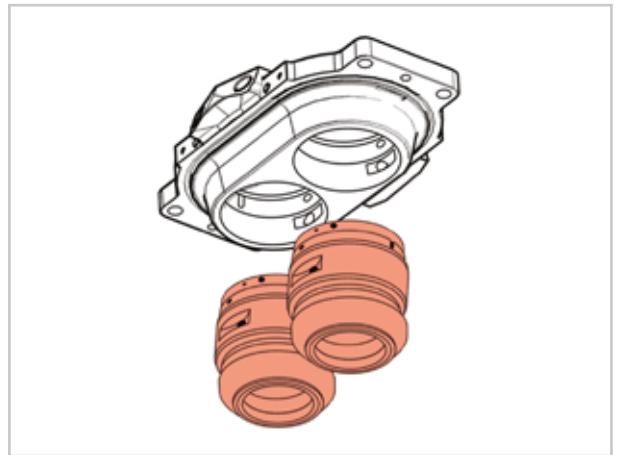
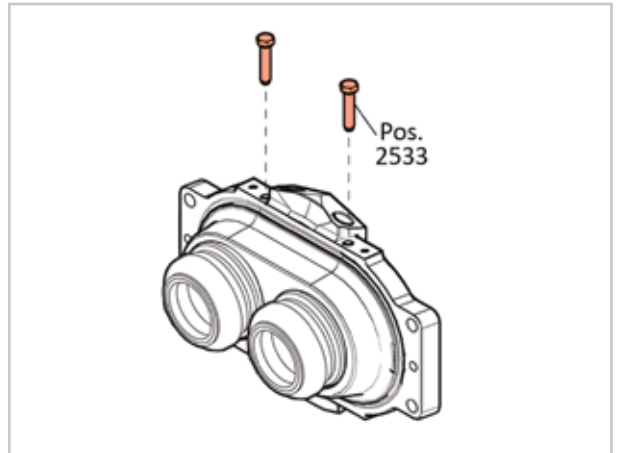

**STEP 7)**

**INSPECTING THE PUMP PARTS**

A. Pump Housing should be smooth inside and not show any rough spots.

B. Both spindles should show smooth surfaces, not be worn from touching or show splintered corners.

C. Both pump shafts need to sit tight without any play or wiggle room in axial and radial direction. If any, there could be very minimal play from the gear wheels. Grip both shafts and wiggle up & down, forward & backwards, and also side to side, to check for excessive wear.

D. If even small movements are detected, it will require a complete bearing replacement before further operation.

E. Inspect both mechanical seals for visible wear and tear. In case the seals are worn, please send it to **Processtec** for refurbishing.

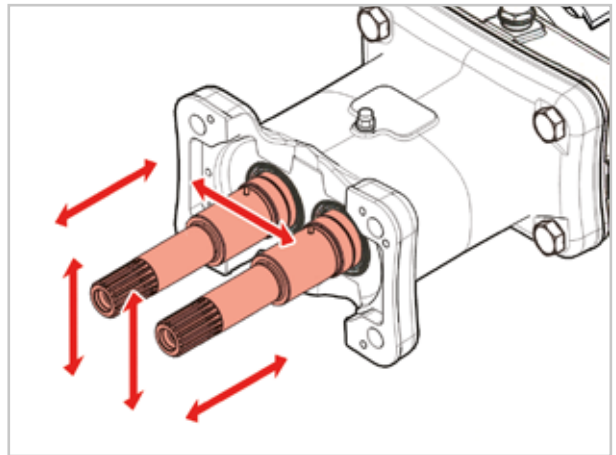
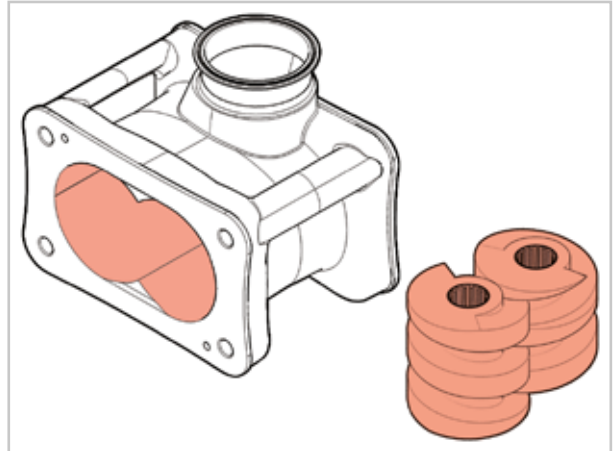

### 4.4.3 Complete Pump Assembly

To assemble the pump, follow each of the steps outlined in this section.

#### Required Tools:

- Small 7mm Wrench (for Pos. 2532)
- 5mm Socket Hex Nut (for Pos. 2259)
- 8mm Socket Hex Nut (for Pos. 3002)
- 10mm Socket Hex Nut (for Pos. 2533)
- 24mm Socket Hex Nut (for Pos. 1016 & 2527)
- 30mm Spindle Screw (for Pos. 2180)
- Torque Wrench - Small (1/4" Drive, Capable of Torque ranging from 8 to 15 Nm)
- Torque Wrench - Large (1/2" Drive, Capable of Torque up to 150 Nm)

#### Action steps for complete pump disassembly:

- STEP 1)** Removing the Protection Shields
- STEP 2)** Installing both seals into the Seal Housing
- STEP 3)** Installing Seal Housing into Bearing Housing
- STEP 4)** Reseating the Mechanical Seals
- STEP 5)** Reinstalling the Protection Shields
- STEP 6)** Installing both Spindles
- STEP 7)** Fixating the Spindles
- STEP 8)** Removal of Shaft Blocking Tool
- STEP 9)** Reinstall the Lantern Safety Guard
- STEP 10)** Verify that Spindles Spin Freely
- STEP 11)** Check Gapping of Spindles
- STEP 12)** Tighten Hex Screws
- STEP 13)** Install Pump Housing
- STEP 14)** Installing Pump Face to Pump Housing

**STEP 1)**

**REMOVING THE PROTECTION SHIELDS**

Remove both Protection Shields (Pos. 2546 & Pos. 2547) on the Seal Housing (Pos. 2188).

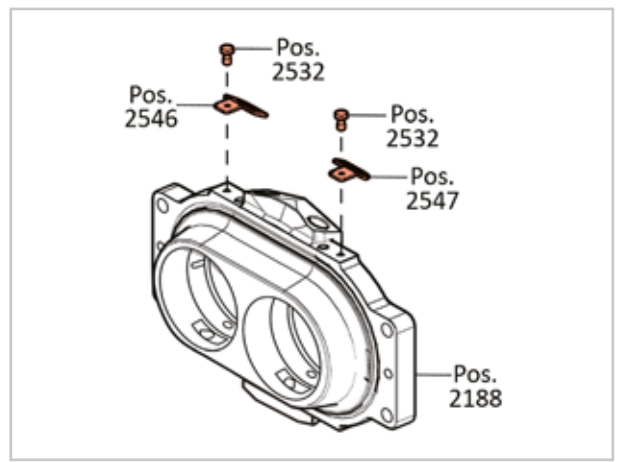

**STEP 2)**

**INSTALLING BOTH SEALS INTO THE SEAL HOUSING**

A. Lightly lubricate all exposed elastomers at both mechanical seals with the delivered silicone-based lubricant. Adding too much lubricant can be detrimental to properly seating the O-rings.

B. Install Mechanical Seals (Pos. 2535) into the Seal Housing (Pos. 2188), making sure that they align with the Pin for Mechanical Seal (Pos. 2538).

C. Be sure that the Mechanical Seals are pressed all the way into the Seal Housing, and that both are seated evenly.

D. Lightly re-install both Hex Head Cap Screws for Mechanical Seal (Pos. 2533) into the Seal Housing (Pos. 2188), and hand tighten to make sure that the seals are held in place.

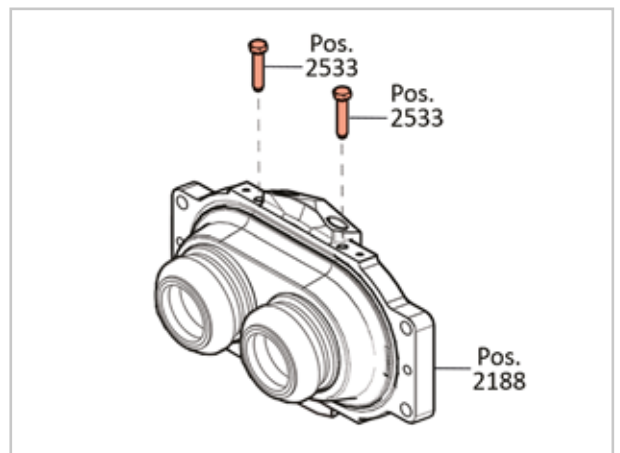
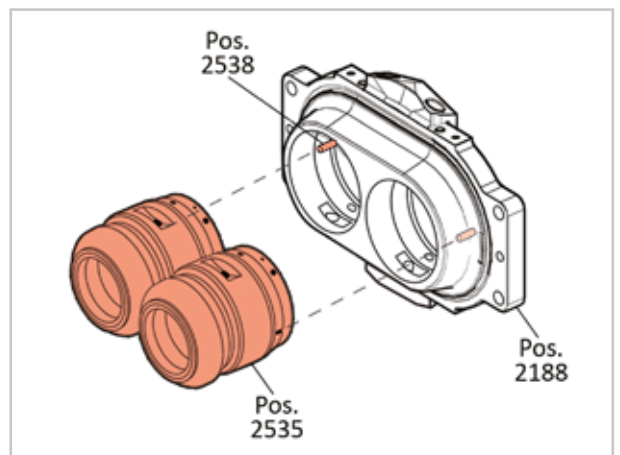



**STEP 3)**

**INSTALLING SEAL HOUSING INTO BEARING HOUSING**

Next, install the Seal Housing (Pos. 2188) containing both Mechanical Seals onto the Bearing Housing (Pos. 1001). This involves lining up two pairs of Alignment Pins.

A. First, align the Seal Housing (Pos. 2188) with the TWO (2) Alignment Pins for Seal Housing (Pos. 2536) on the Bearing Housing (Pos. 1001).

B. Second, you must also line up the notches in the sleeve of both Mechanical Seals with both Shaft Alignment Pins (Pos. 2541).

C. Tighten all FOUR (4) Socket Head Cap Screws (Pos. 2259) and torque to 12 Nm, securing the Seal Housing and Mechanical Seals to the Bearing Housing (Pos. 1001).

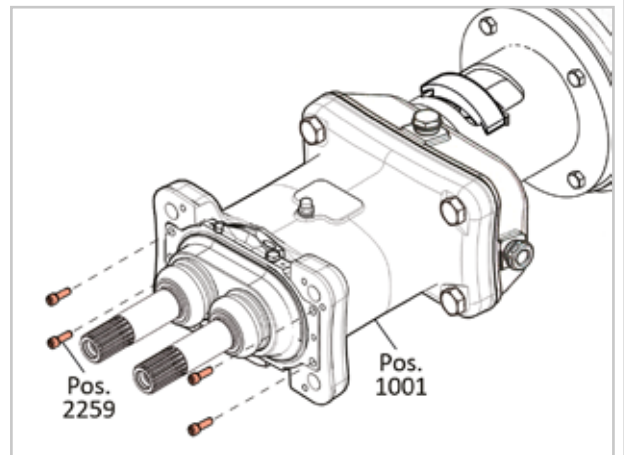
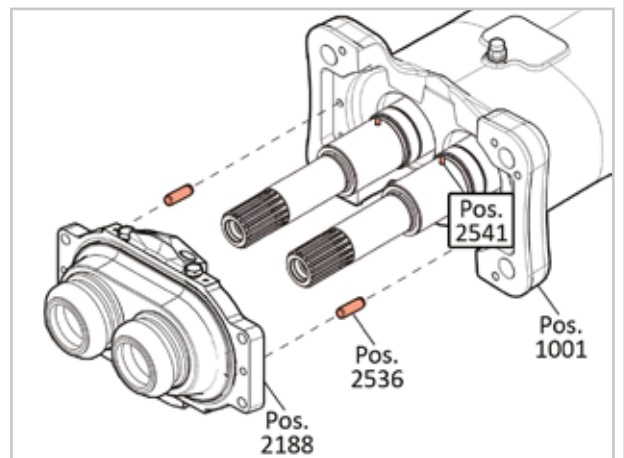

**STEP 4)**  
RESEATING THE MECHANICAL SEALS

Loosen both Hex Head Cap Screws (Pos. 2533) slightly and push the Mechanical Seals (Pos. 2535) by hand all the way to the back into the housing. It could have been minimally shifted during the installation.

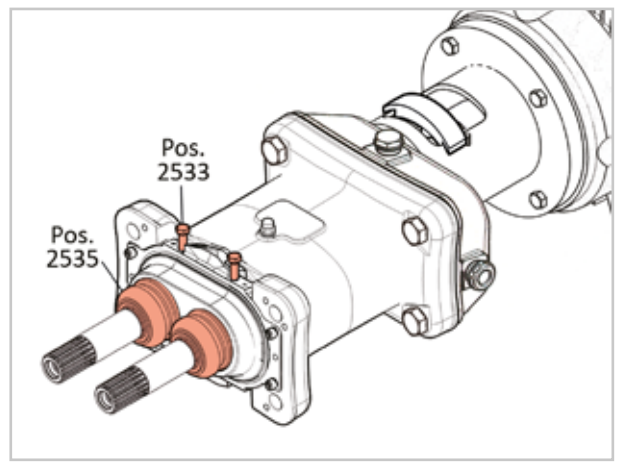

**STEP 5)**  
REINSTALLING THE PROTECTION SHIELDS

Re-install the TWO (2) Protection Shields (Pos. 2546 & Pos. 2547).

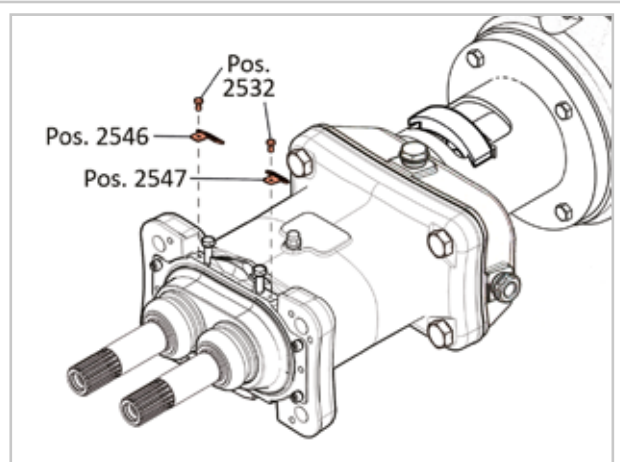

**STEP 6)**

INSTALLING BOTH SPINDLES (Pos. 2200 & 2201).

A. Loosen both Hex Head Cap Screws for Mechanical Seals (Pos. 2533) on the Seal Housing (Pos. 2188) so that the Mechanical Seals can be pushed all the way into the Bearing Housing.

B. Determine whether you have Spindle Configuration "A" or "V", based on your Pump Housing Configuration (Please refer to Section 5.5 "Pump Housing Configuration" on page 100 for more detailed information on identifying "A" or "V" Spindle Configurations).

C. Place both spindles (Pos. 2200 & 2201) on a clean dry surface, with the spline sides facing downwards, and align them into either "A" or "V" configurations.

D. Rotate both spindles until they are aligned from the top view as shown to the right, where the colored/highlighted flat top surfaces of the spindles sit totally flush with each other.

E. Pick up both Spindles, taking care to keep them aligned with each other in the current position, and place them onto the shafts, rotating them very slightly inwards and outwards, until they slide onto the Drive Shaft and Driven Shaft splines. Before proceeding to the next step, be sure to check that the Spindles are still aligned properly. If both Spindle surfaces are still flush with each other, then you have achieved proper alignment.

F. Press the Spindles towards the Product Side of the Bearing Housing (Pos. 1001) until they are flush up against the Seal O-Ring of the Mechanical Seals (Pos. 2535).

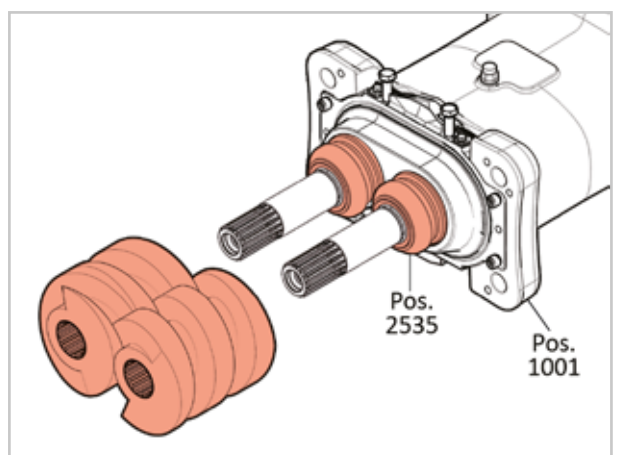
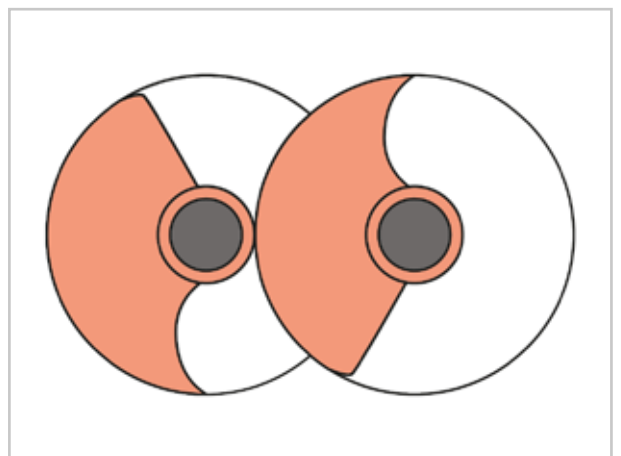
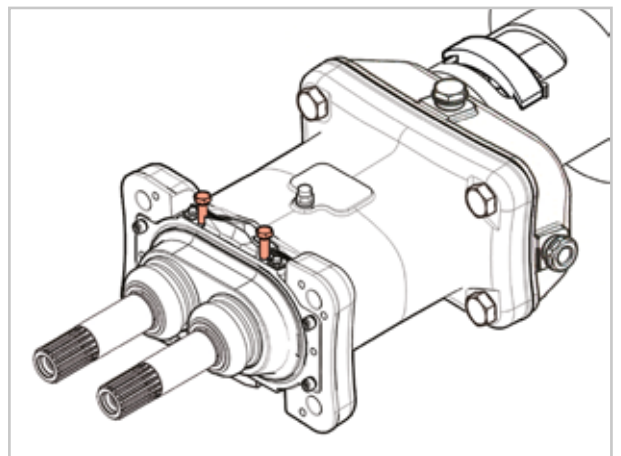

**STEP 7)**  
FIXATING THE SPINDLES

To fixate the spindles, use the Spindle Screws (Pos. 2180) with O-rings (Pos. 2194). Add a small amount of Blue Loctite™ to the Spindle Screw threads to secure it. Torque both Spindle Screws to 150 Nm.

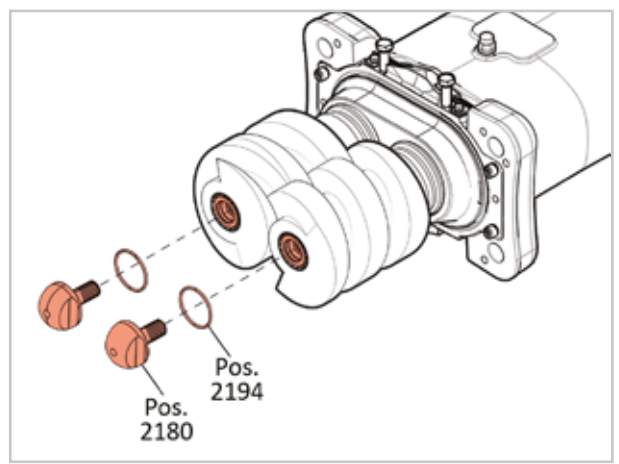

**STEP 8)**  
REMOVAL OF SHAFT BLOCKING TOOL

Remove the shaft blocking tool in the lantern area.

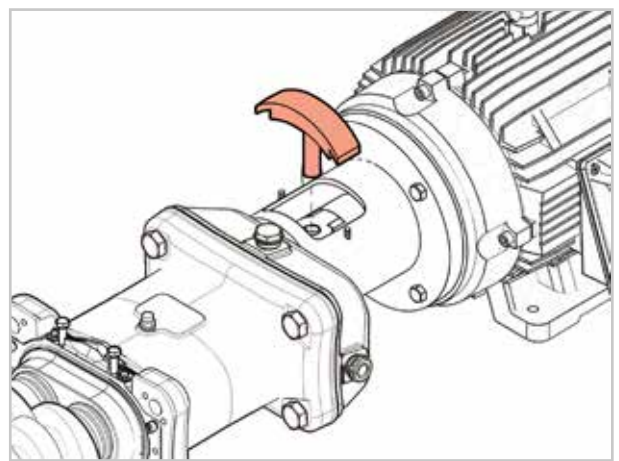

**STEP 9)**  
REINSTALL THE LANTERN SAFETY GUARD

Re-install the Lantern Safety Guard (Pos. 3001) with the Cap Nuts for Lantern Safety Guard (Pos. 3002).

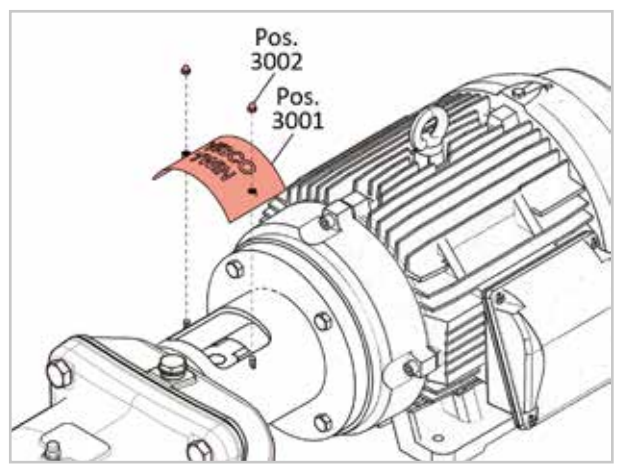

**STEP 10)**

**VERIFY THAT SPINDLES SPIN FREELY**

Verify while turning both spindles by hand that they are spinning freely. Then hold a white paper underneath the spindles and visually check that there is an even gap between the spindle flights. The spindles are not allowed to touch.

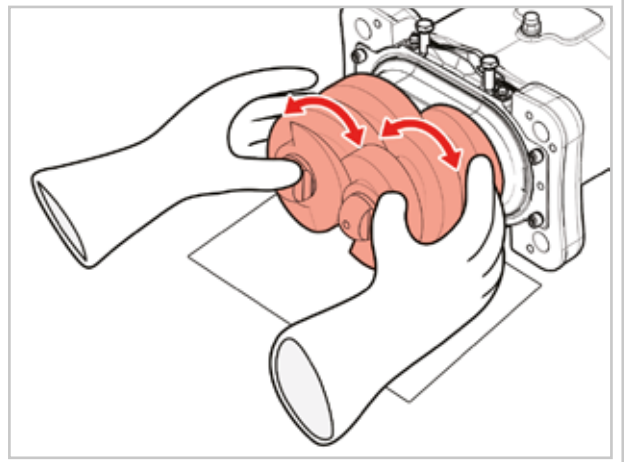

**STEP 11)**

**CHECK GAPPING OF SPINDLES**

In case the spindles touch each other, the shafts need to be gapped (See Subsection 4.5.8 "Proper Gapping of Pump" on page 68). In case that the tolerances between the flights are not equal but do not touch, gapping is not absolutely necessary.

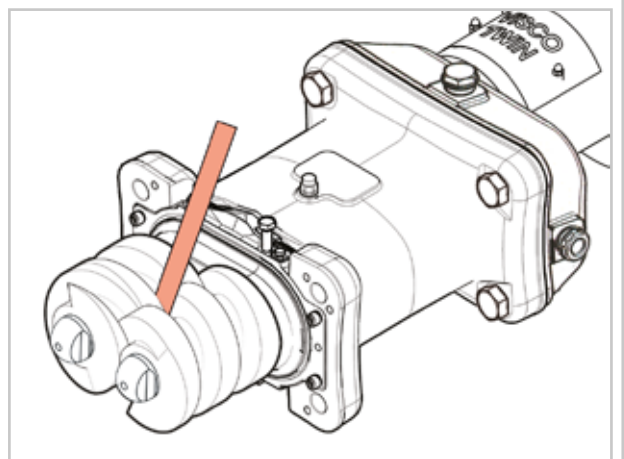

**STEP 12)**

**TIGHTEN HEX SCREWS**

Snug tighten both Hex Head Cap Screws for Mechanical Seals (Pos. 2533) on the Seal Housing (Pos. 2188).

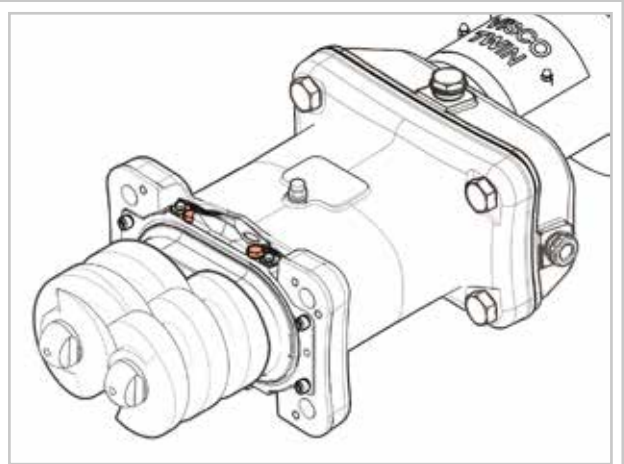

**STEP 13)**

**INSTALL PUMP HOUSING**

Verify that the O-ring (Pos. 1088) is correctly seated and that both Alignment Pins (Pos. 2195) are installed in the proper locations based on your pump's Pin Configuration (see Section 5.5 "Pump Housing Configuration" on page 100). Carefully slide the Pump Housing (Pos. 2530) onto the spindles, and then tighten and torque all FOUR (4) hex screws (Pos. 1016) to 150 Nm.

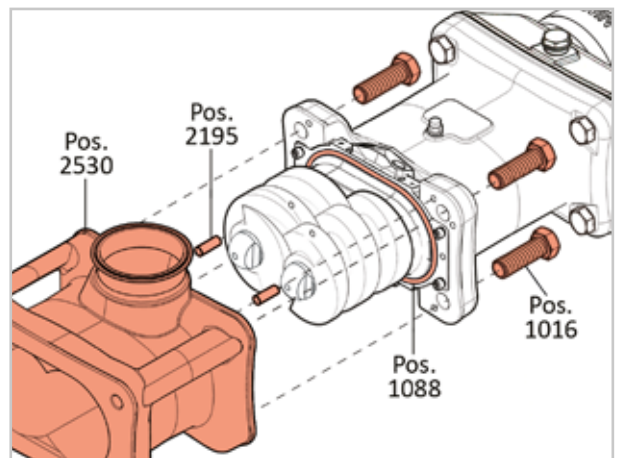

**STEP 14)**

**INSTALLING PUMP FACE TO PUMP HOUSING**

Install the Pump Face to the Pump Housing. Verify that both Alignment Pins (Pos. 2196) are in position and O-ring (Pos. 2192) is correctly in place. Tighten the FOUR (4) hex screws (Pos. 2527) to 150 Nm.

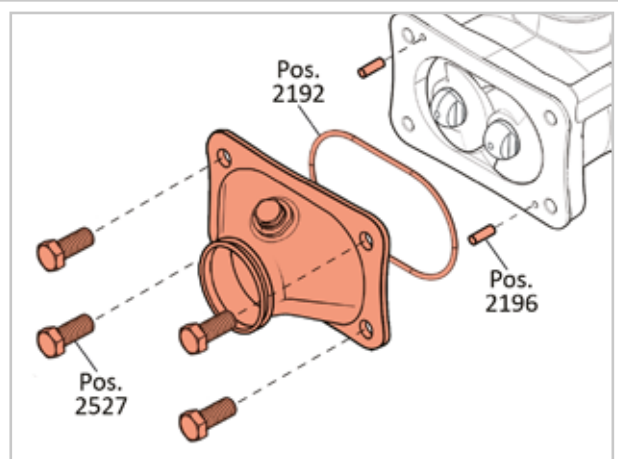

## **4.5 Preventative Maintenance Program**

### **4.5.1 First Oil Change**

A) The First Oil Change is required after 250 hours of operation, or 3 months (whichever comes first). This is known as the Break-In period.

### **4.5.2 Oil Change Intervals**

A) After the first Oil Change is completed, sample & test the oil every 3 months for condensed water and debris.

B) Based on the results of the oil test, change if necessary. For more information about oils and oil testing, please see Section 5.6 "Oils, Grease & Lubrication Recommended" on page 108 and Section 5.7 "Oil Testing Kit" on page 110.

C) As a rule of thumb, the oil should last for 2000 to 3000 operating hours, or approximately 6 months.

### **4.5.3 Checking Levels on Motor Gearbox Oil**

If the pump is motorized with a gearmotor, the gearbox needs gear oil as well. Please follow the instructions in the Motor Manual.

### **4.5.4 Greasing Motor Bearings**

A) Motor Bearings must be properly greased according to the Motor Manufacturer's recommendations, which is typically every 3 months. Failure to do so could result in the motor not operating at peak performance, and can possibly lead to permanent motor damage or improper motor function.

**4.5.5 Check Condition of O-rings**

There are THREE (3) O-rings that need to be inspected to be sure they are free from damage in order for the ViscoTwin pumps to work correctly:

- Pos. 2192 (O-rings for Pump Face)
- Pos. 2194 (O-rings for Spindle Screws)
- Pos. 1088 (O-rings for Seal Housing)

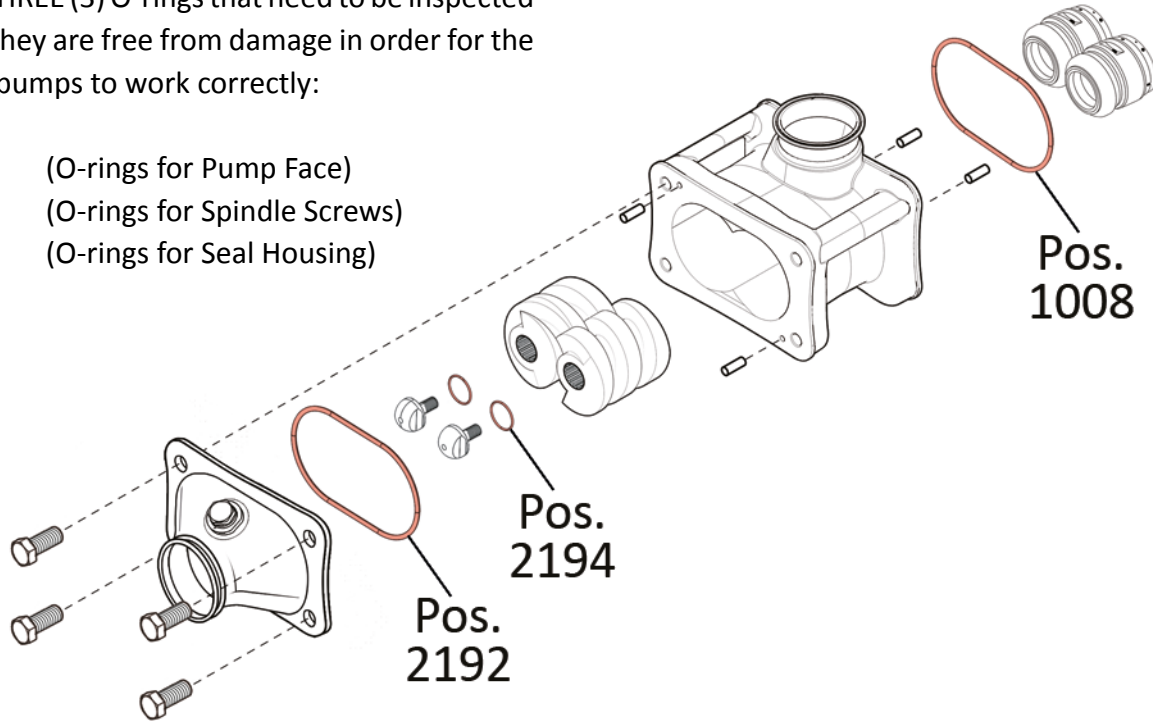

**4.5.6 Check the Exterior Lip Seals and O-rings on the Mechanical Seals**

Inspect the Lip Seal (1) and O-Rings (2, 3 & 4) at the locations shown below for signs of damage.





### 4.5.7 Check Oil Shaft Sealing Rings

Check the condition of the Oil Shaft Sealing Rings (Pos. 2322 & 1010) on the Bearing Housing (Pos. 1001) and also on the Gear Housing (Pos. 2172).

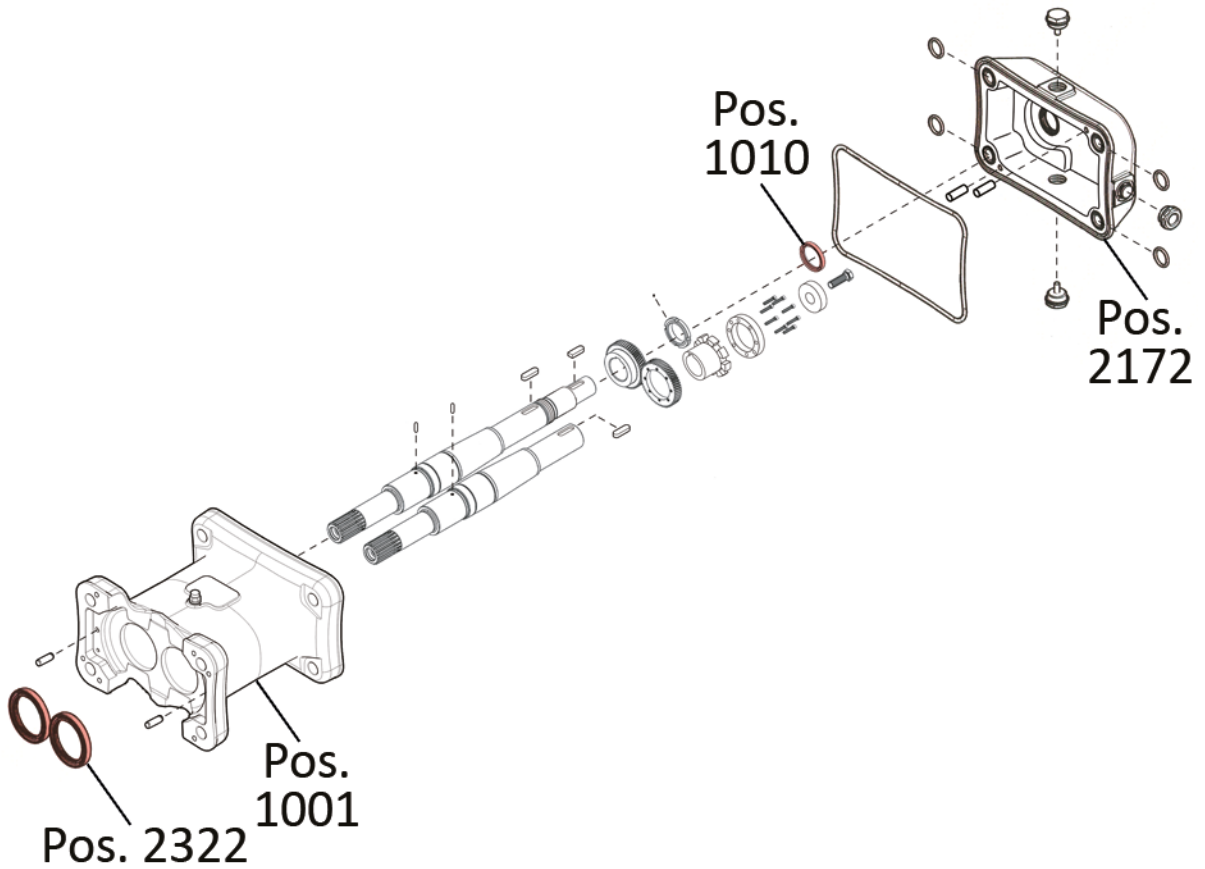

### 4.5.8 Proper Gapping of Pump

In case foreign material entered the pump housing and blocked the spindles, the gear synchronization lock ring (Pos. 2515) might have slipped. The “S” clearances between the spindles shifted to the extent that the spindles touch and block each other. In this case the pump needs to be gapped.

Gapping means that the “S” clearances between the spindle flights need to be evenly distributed while turning the driven shaft into the “middle position”. Successful gapping results in the “S” clearances measuring all the same (S10, S20, S30, S40).

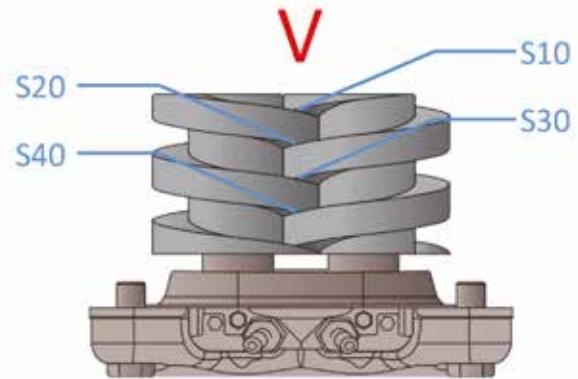

#### STEP 1a)

If your pump is equipped with a Gear Housing Inspection Port (Pos. 3100, only available as an option on the Stainless Steel versions of the **ViscoTwin** Pumps), you will need to remove it so that the Socket Head Screws (Pos. 2186) can be loosened while turning the shaft by hand on the Spindles.

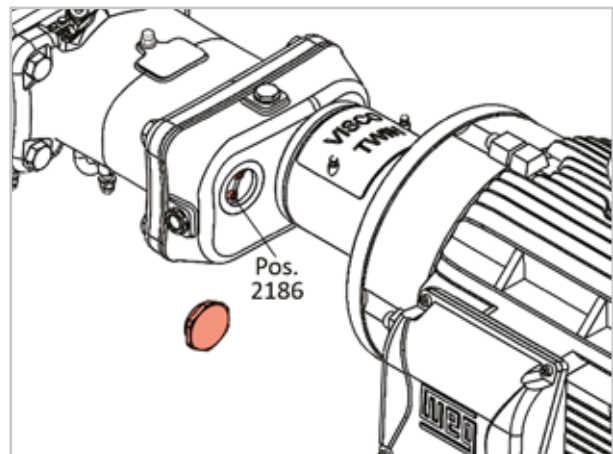

#### STEP 1b)

In case your pump is not equipped with the Gear Housing Inspection Port, the Gear Housing (Pos. 2172) needs to be removed in order to gain access to the Socket Head Cap Screws (Pos. 2186) for the Gear Synchronization Lock Ring (Pos. 2515). In this case, follow the steps below, and then continue with Step 2.

- Remove the Pump Coupling Hub (Pos. 2247).
- Remove the Key (Pos. 1183) on the Drive Shaft by Ear Clamp Pliers.
- Drain the Oil.
- Loosen the FOUR (4) bolts (Pos. 2258) on the Gear Housing.
- Carefully slide down the Gear Housing.

**STEP 2)**

Remove the Pump Housing while removing FOUR (4) Hex Head Cap Screws (Pos. 1016). When the screws are removed, the Pump Housing (Pos. 2530) can be removed. The Pump Face (Pos. 2528) does not have to be removed from the Pump Housing.

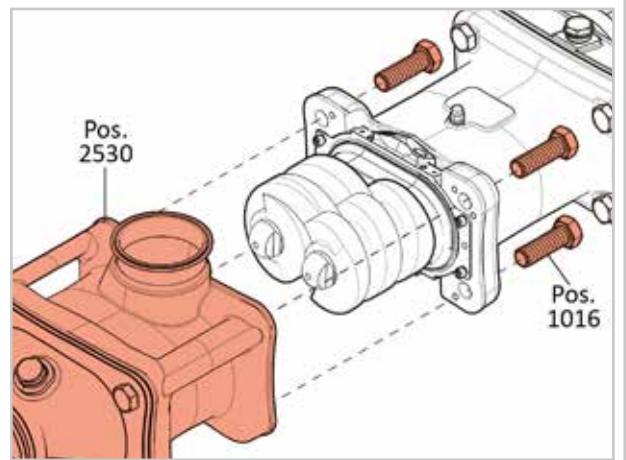

**STEP 3)**

Fixate the Drive Shaft (Pos. 1000) by holding the Drive Shaft Spindle (Pos. 2200) by hand, and turning the Driven Shaft Spindle (Pos. 2201) to one end with the other hand, until both spindles touch each other at position S20 and S40.

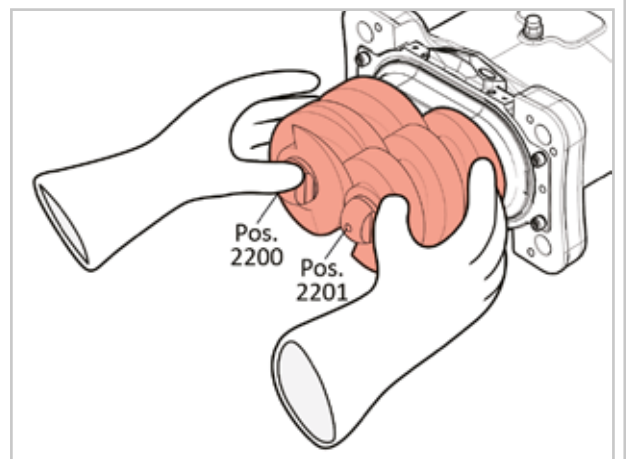

**STEP 4)**

Measure the gap position S30 with a feeler gauge. Divide that clearance in 2. (For example, if the clearance at S30 was 0.30mm, you will end up with .15mm). This is known as the "half-gap" dimension.

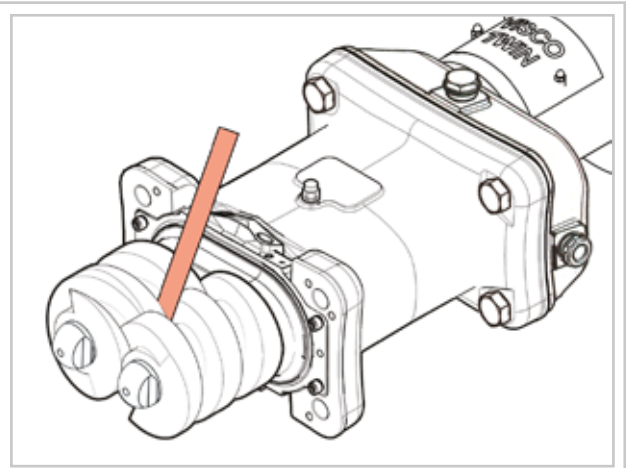

**STEP 5)**

Select a feeler gauge that is sized to this "half-gap" dimension, and insert it at S30, for use as a shim.

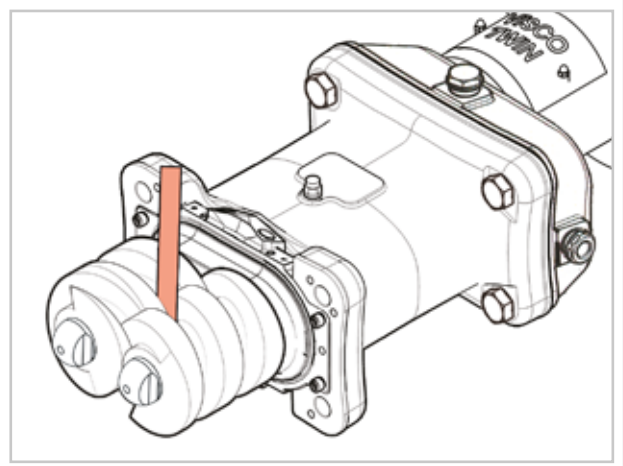

**STEP 6)**

Turn the Driven Shaft Spindle (Pos. 2201) until it closes onto the feeler gauge/shim at S30. If done correctly, this will now give you the exact same gap at S20.

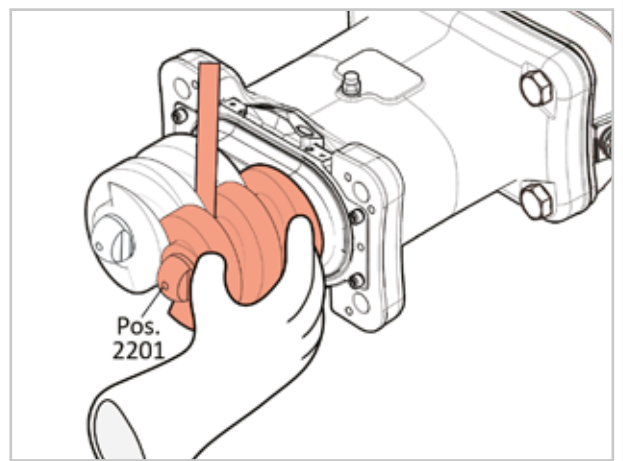

**STEP 7)**

Hand tighten just ONE (1) Socket Head Cap Screw (Pos. 2186). The shaft should be blocked and both spindles turn synchronized.

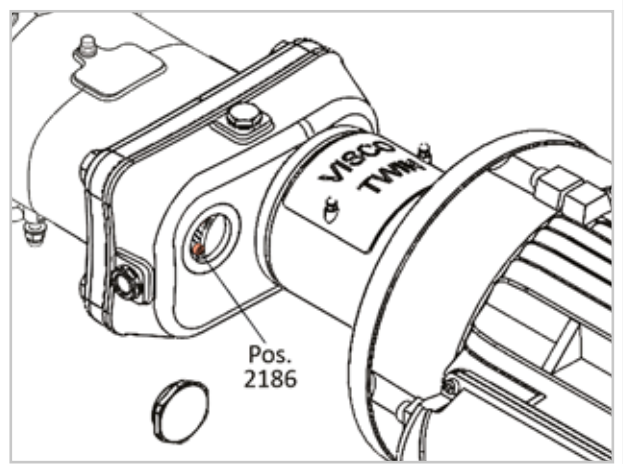

**STEP 8)**

Verify that S20 and S30 are now the same (or at least within .05mm). S10 will natively match with S30 and S20 will natively match with S40. Depending on the shape of the spindles used, a close value is good enough. The spindles are not allowed to touch anywhere, however. If that were to be the case, the spindles are severely damaged and probably need to be replaced.

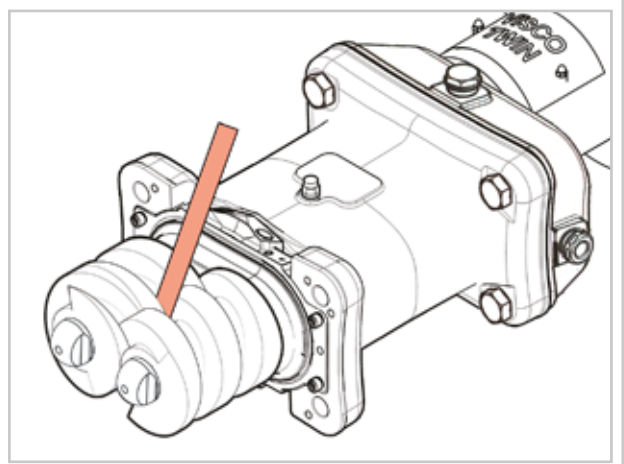

**STEP 9)**

While hand turning the Spindles, verify that the shafts turn freely. Also verify, by holding a white sheet of paper underneath the spindles and then shining a flashlight upwards, that the gaps are clear from galls as well.

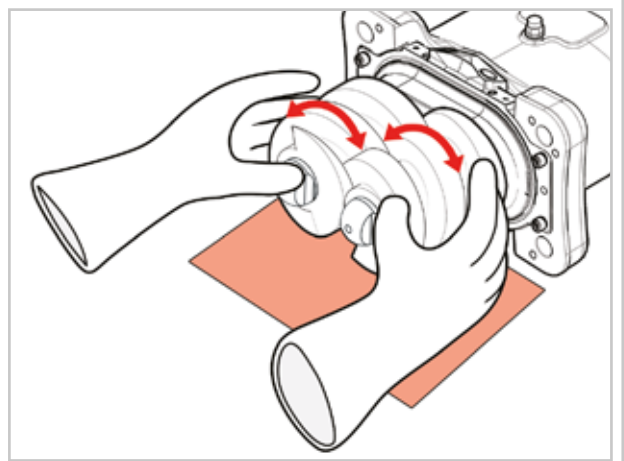

**STEP 10)**

Fixate the Gear Synchronization Lock Ring (Pos. 2515) while tightening the EIGHT (8) Socket Head Cap Screws (Pos. 2186) to 8 Nm (5.9 lb-ft.).

Now you can re-assemble the pump.

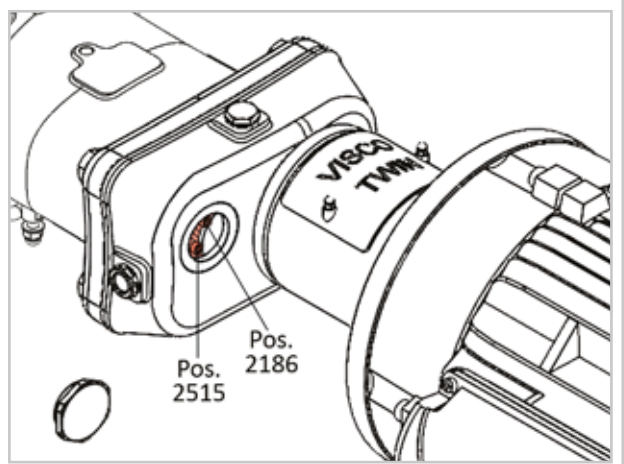

**4.5.9 Changing Product Flow Direction**

To change Product Flow Direction from any configuration, you will need to do ONLY ONE of the two following options:

**OPTION 1**

Change Spindle Arrangement from "V to A" or "A to V"

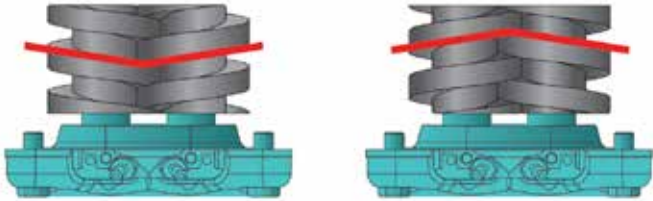

**SPINDLE ARRANGEMENT: V**

**SPINDLE ARRANGEMENT: A**

**OR**

**OPTION 2**

Step 1) Change Rotation from "O to I" or "I to O"

Step 2) Switch the Pin Arrangement from "3 to 1" or "1 to 3"

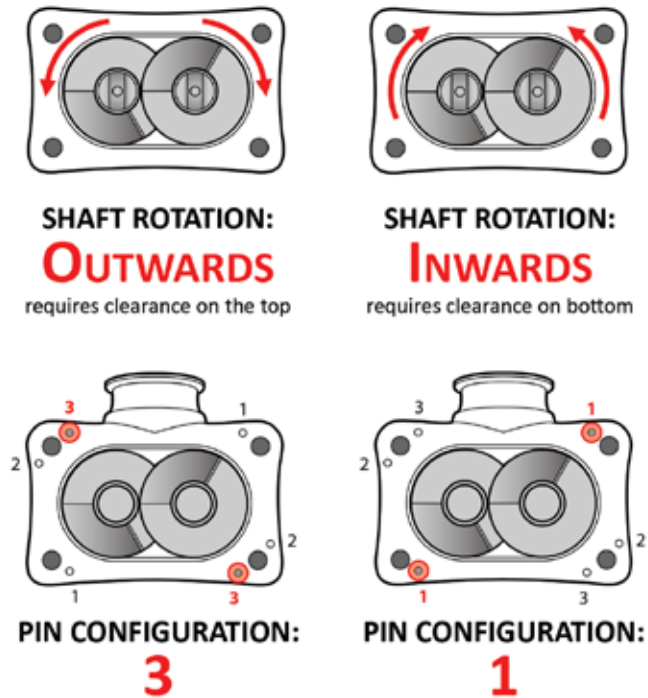

**SHAFT ROTATION: OUTWARDS**  
requires clearance on the top

**SHAFT ROTATION: INWARDS**  
requires clearance on bottom

**PIN CONFIGURATION: 3**

**PIN CONFIGURATION: 1**

**4.6 Failures**

**4.6.1 Foreign Material enters Pump Housing**

**STEP 1)**

Remove Pump Housing.

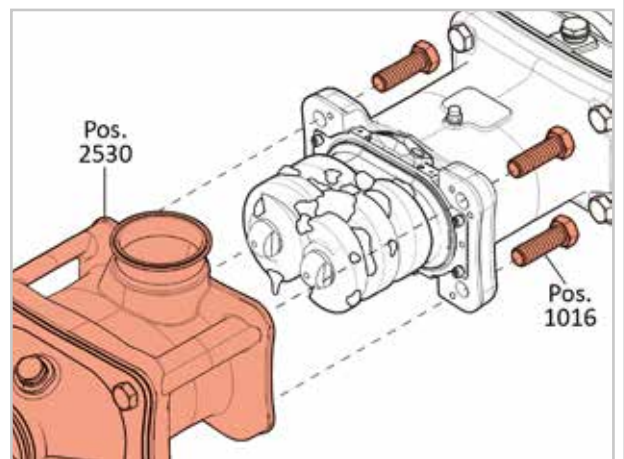

**STEP 2)**

Clean Area.

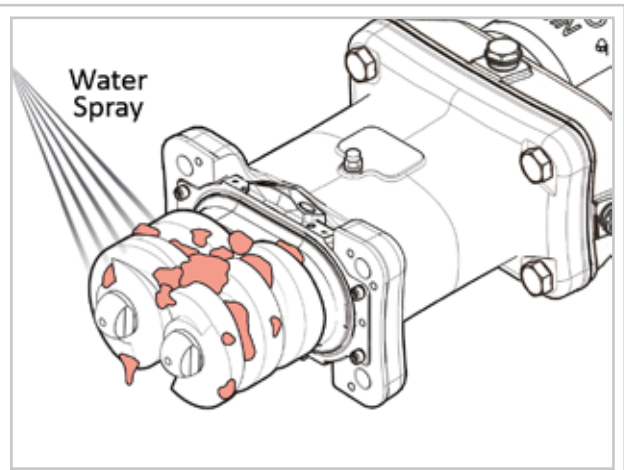

**STEP 3)**

Inspect shaft for axial & radial movement by hand.

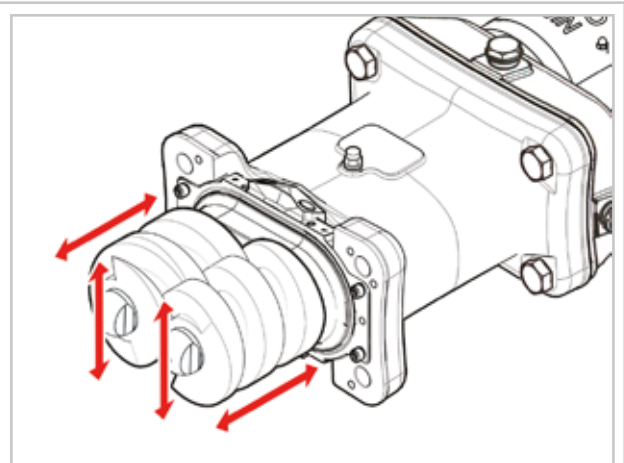

**STEP 4)**

Inspect if spindles turn by hand. Visually inspect the condition of the spindles.

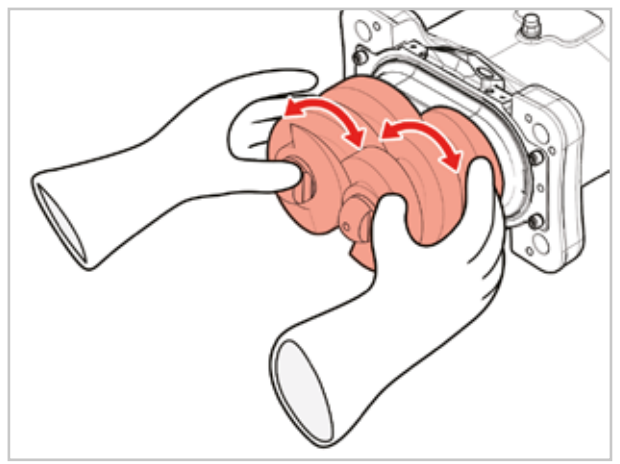

**STEP 5)**

Inspect the spindles and housing condition for debris, scars, and crevices. If necessary, gap or time the spindles.

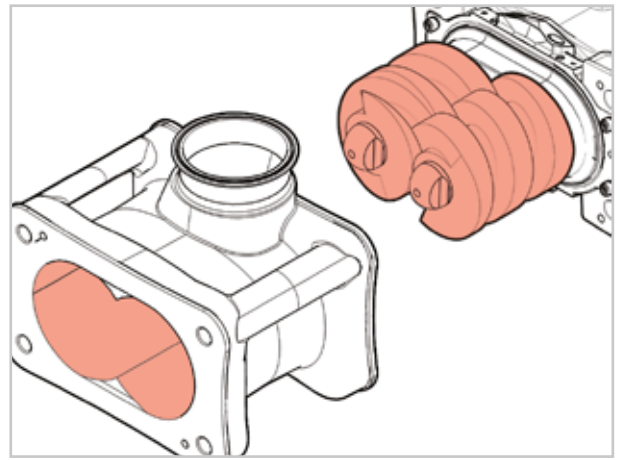

**STEP 6)**

Gapping and/or timing can be necessary if spindles need to be replaced.

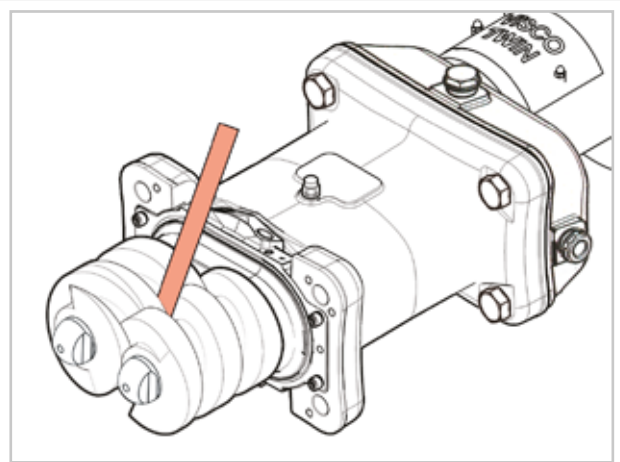



## 5. TOOL-BOX

### 5.1 Tools

Below are all of the Tools that are available from **Processtec** for use on the **ViscoTwin** pumps:

#### 5.1.1 ViscoTwin Tools

Complete Tool Box ML2_VT104_G7, G8+, NG				--
Part #	Material	Description	Pump Generation	
22659	Various	Complete Tool Box Maintenance Level 2	G7, G8+, NG	
<p><b>NOTES:</b> To replace a missing or damaged tool, simply place an order with <b>PROCESSTEC, Inc.</b> using the part numbers that are listed on the following pages.</p>				
				

T0038_Spindle Wrench_VT104, VT130_G7, G8+, NG				for Pos. 2180
Part #	Material	Tool #	Pump Generation	
12567	Aluminum	T0038	G7, G8+, NG	
<p><b>NOTES:</b> To loosen and tighten Slotted Spindle Bolts</p>				

T0038_Brass Hex Nut_VT104, VT130_G7, G8+, G9				for Pos. 2180
Part #	Material	Tool #	Pump Generation	
23254	Brass, 36mm	T0038	G7, G8+, NG	
<p><b>NOTES:</b> To loosen and tighten Hex Head Spindle Bolts. Includes 1/2" to 3/4" Adapter.</p>				

T0047_Mounting Cone for Shaft Seal Ring Gear Housing_VT104_G7, G8+, NG				for Pos. 1010/1183
Part #	Material	Tool #	Pump Generation	
12587	304	T0047	G7, G8+, NG	
<p><b>NOTES:</b></p>				

T0082_Press Fitting Mandrel Shaft Sealing Ring_VT104_G7, G8+, NG				for Pos. 1010
Part #	Material	Tool #	Pump Generation	
18776	304	T0082	G7, G8+, NG	
<b>NOTES:</b>				

T0083_Mounting Cone Shaft Seal Ring Bearing Housing_VT104_G7				for Pos. 1111
Part #	Material	Tool #	Pump Generation	
12569	304	T0083	G7	
<b>NOTES:</b>				

T0083_Mounting Cone Shaft Seal Ring Bearing Housing_VT104_G8+, NG				for Pos. 2322
Part #	Material	Tool #	Pump Generation	
23069	304	T0083	G8+, NG	
<b>NOTES:</b>				

Pump Drive Shaft Blocking Tool				for Pos. 3000/2247
Part #	Material	Size	Pump Generation	
21768	316	SIT Couplers	G8+, NG	
23472	316	R+W Couplers	G8+, NG	
<p><b>NOTES:</b></p>				

5.1.2 General Tools

Torque Wrench Large				--
Part #	Material	Size	Pump Generation	
21852	--	1/2" drive, 30-340 Nm	G7, G8+, NG	
<p><b>NOTES:</b> <i>For high torque application</i></p>				

Torque Wrench Medium				--
Part #	Material	Size	Pump Generation	
21851	--	3/8" drive, 10-135 Nm	G7	
<p><b>NOTES:</b> <i>For medium torque application</i></p>				

Torque Wrench Small				--
Part #	Material	Size	Pump Generation	
21873	--	1/4" drive, 2.5-25 Nm	G7, G8+, NG	
<p><b>NOTES:</b> <i>For small torque application</i></p>				

Hex Nuts (Various Sizes)				for Pos. per Torque Table
Part #	Material	Size	Pump Generation	
21853	--	10mm (3/8" drive)	G7	
21854	--	13mm (1/2" drive)	G7	
21915	--	16mm (1/2" drive)	G7, G8+, NG	
22108	--	17mm (1/2" drive)	G8+, NG	
21910	--	18mm (1/2" drive)	G7	
21855	--	19mm (1/2" drive)	G7	
21911	--	22mm (1/2" drive)	G7	
21856	--	24mm (1/2" drive)	G7	
21857	--	27mm (1/2" drive)	G7, G8+, NG	
21858	--	30mm (1/2" drive)	G7, G8+, NG	
21912	--	32mm (1/2" drive)	G7, G8+, NG	
<p><b>NOTES:</b> Operate on positions per chart.</p>				

Hex Socket Bits Set (13 Piece)				for Pos. see notes
Part #	Material	Size	Pump Generation	
21828	CVS	2mm to 14mm	G7, G8+, NG	
<p><b>NOTES:</b> Operate on positions per chart For Pos. 1008, 2246, 2247, 2248, 2258</p>				

Pliers				for Pos. 1183
Part #	Material	Size	Pump Generation	
21844	--	--	G7, G8+, NG	
<b>NOTES:</b>				

Hex Socket Screw Drivers				for Pos. see Notes
Part #	Material	Size	Pump Generation	
21913	--	7mm	G7, G8+, NG	
22405	--	8mm	G8+, NG	
21914	--	10mm	G7, G8+, NG	
<b>NOTES:</b> 7mm used on Pos. 2287/3532 8mm used on Pos. 3002 10mm used on Pos. 2259/3533				

Feeler Gauge Metric				--
Part #	Material	Size	Pump Generation	
21847	303	--	G7, G8+, NG	
<b>NOTES:</b> Long blades to verify gaps in Spindles, Housing.				

Set of Small Hooks for Removal of O-Rings				--
Part #	Material	Size	Pump Generation	
21848	SS	--	G7, G8+, NG	
<p><b>NOTES:</b> Operate on positions per chart</p>				

Hex Socket Extension				--
Part #	Material	Size	Pump Generation	
21874	--	9"	G7	
<p><b>NOTES:</b> For 1/2" Drive</p>				

Breaker Wrench				for Pos. 4410
Part #	Material	Size	Pump Generation	
22488	--	18" Long (1/2" Drive)	G7, G8+, NG	
<p><b>NOTES:</b></p>				



Grease Tube				for Various Elastomers
Part #	Material	Size	Pump Generation	
22260	--	--	G7, G8+, NG	
<b>NOTES:</b>				

Open Spanner (Wrench) 10mm				for Pos. 3002
Part #	Material	Size	Pump Generation	
22489	--	10mm	G7, G8+, NG	
<b>NOTES:</b>				

Wrench for Operating Hex Nuts				for Pos. 2532/2533
Part #	Material	Size	Pump Generation	
21849	--	3/8" Drive	G7	
21850	--	1/2" Drive	G7	
<b>NOTES:</b>				

Flat Tire Lever				for Pos. 4000
Part #	Material	Size	Pump Generation	
21846	--	24"	G7	
<p><b>NOTES:</b> Blocking of the Coupling on G7 Pumps to loosen or tighten Spindle</p>				

**5.2 Spare Parts**

Below is a list of the Spare Parts that are available from **Processtec** for use on the **ViscoTwin** pumps:

**5.2.1 Spare Parts for Pump Housing**

<b>Spindle Bolt_VT104, VT130_G7, G8+, NG</b>				<b>Pos. 2180</b>
<b>Part #</b>	<b>CUSTOMER REFERENCE #</b>	<b>Material</b>	<b>Specification</b>	
18826		316L	--	
23113		316L	Hex Style	
<b>NOTES:</b>				

<b>O-Ring for Spindle Screw_VT104, VT130_G7, G8+, NG</b>				<b>Pos. 2194</b>
<b>Part #</b>	<b>CUSTOMER REFERENCE #</b>	<b>Material</b>	<b>Specification</b>	
12504		FKM	DIN3771-42x3,0	
12510		EPDM	DIN3771-42x3,0	
<b>NOTES:</b>				

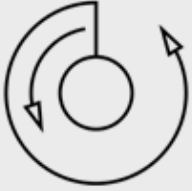
Spindle Left Handed_G7, G8+, NG				Pos. 2200	
Part #	Specific Model Name	Material	Specification		
21811	Spindle (Left Handed) VT104.27SEH	316	27mm Standard, EH		
21812	Spindle (Left Handed) VT104.27S3A	316	27mm Standard, 3A		
21813	Spindle (Left Handed) VT104.27HEH	316	27mm Hardened, EH		
21814	Spindle (Left Handed) VT104.27H3A	316	27mm Hardened, 3A		
12633	Spindle (Left Handed) VT104.36SEH	316	36mm Standard, EH		
14258	Spindle (Left Handed) VT104.36S3A	316	36mm Standard, 3A		
14256	Spindle (Left Handed) VT104.36HEH	316	36mm Hardened, EH		
17547	Spindle (Left Handed) VT104.36H3A	316	36mm Hardened, 3A		
12632	Spindle (Left Handed) VT104.53SEH	316	53mm Standard, EH		
12626	Spindle (Left Handed) VT104.53S3A	316	53mm Standard, 3A		
14254	Spindle (Left Handed) VT104.53HEH	316	53mm Hardened, EH		
19980	Spindle (Left Handed) VT104.53H3A	316	53mm Hardened, 3A		
<p><b>NOTES:</b> Rotation Direction</p> 					

Spindle Right Handed _G7, G8+, NG				Pos. 2201
Part #	Specific Model Name	Material	Specification	
21817	Spindle (Right Handed) VT104.27SEH	316	27mm Standard, EH	
21818	Spindle (Right Handed) VT104.27S3A	316	27mm Standard, 3A	
21819	Spindle (Right Handed) VT104.27HEH	316	27mm Hardened, EH	
21820	Spindle (Right Handed) VT104.27H3A	316	27mm Hardened, 3A	
12635	Spindle (Right Handed) VT104.36SEH	316	36mm Standard, EH	
18489	Spindle (Right Handed) VT104.36S3A	316	36mm Standard, 3A	
14260	Spindle (Right Handed) VT104.36HEH	316	36mm Hardened, EH	
17545	Spindle (Right Handed) VT104.36H3A	316	36mm Hardened, 3A	
12634	Spindle (Right Handed) VT104.53SEH	316	53mm Standard, EH	
12627	Spindle (Right Handed) VT104.53S3A	316	53mm Standard, 3A	
21806	Spindle (Right Handed) VT104.53HEH	316	53mm Hardened, EH	
19981	Spindle (Right Handed) VT104.53H3A	316	53mm Hardened, 3A	
<p><b>NOTES:</b> Rotation Direction</p> 				

O-Ring for Pump Face_VT104_G7, G8+, NG				Pos. 2192
Part #	CUSTOMER REFERENCE #	Material	Specification	
12505	--	FKM	DIN3771-153.5 x 4	
12511	--	EPDM	DIN3771-153.5 x 4	
<b>NOTES:</b>				

Dowel Pin for Pump Face & Housing_VT70, VT104, VT130_G7, G8+, NG				Pos. 2196
Part #	CUSTOMER REFERENCE #	Material	Specification	
12616	--	316L	DIN7-8h8x16-	
<b>NOTES:</b>				

5.2.2 Spare Parts for Seal Housing

O-Ring Seal Housing_VT104_G7, G8+, NG				Pos. 1088
Part #	CUSTOMER REFERENCE #	Material	Specification	
12503		FKM	DIN3771-142x6,2	
12512		EPDM	DIN3771-142x6,2	
<b>NOTES:</b>				

Elastomer Kit SAMS_VT104_G8+, NG				Pos. 2535 EK
Part #	CUSTOMER REFERENCE #	Material	Specification	
22051		FKM	ANGA, SD: 42mm	
22052		EPDM	ANGA, SD: 42mm	
22061		FKM	HUHNSEAL, SD: 42mm	
22062		EPDM	HUHNSEAL, SD: 42mm	
<b>NOTES:</b>				

Elastomer Kit DAMS_VT104_G8+, NG				Pos. 2535 EK
Part #	CUSTOMER REFERENCE #	Material	Specification	
22059		FKM	ANGA, SD: 42mm	
22060		EPDM	ANGA, SD: 42mm	
21723		FKM	HUHNSEAL, SD: 42mm	
22063		EPDM	HUHNSEAL, SD: 42mm	
<b>NOTES:</b>				

Mechanical Seal SAMS_VT104_G8				Pos. 2535
Part #	CUSTOMER REFERENCE #	Material	Specification	
21964	S3	SIC/SIC, FKM	ANGA, SD: 45mm	
21967	S3	SIC/SIC, EPDM	ANGA, SD: 45mm	
22037	S4	TuC/TuCKE FKM	ANGA, SD: 45mm	
22036	S4	TuC/TuCKE EPDM	ANGA, SD: 45mm	
22042	S1	SIC/SIC, FKM	HUHNSEAL, SD: 42mm	
22040	S1	SIC/SIC, EPDM	HUHNSEAL, SD: 42mm	
22043	S2	TuC/TuCKE FKM	HUHNSEAL, SD: 42mm	
22041	S2	TuC/TuCKE EPDM	HUHNSEAL, SD: 42mm	
21531	SX2	TuC/TuC	HUHNSEAL, SD: 42mm	
<b>NOTES:</b>				





Mechanical Seal DAMS_VT104_G8+, NG				Pos. 2535
Part #	CUSTOMER REFERENCE #	Material	Specification	
21531	D3	SIC/SIC FKM	ANGA, SD: 45mm	
22038	D3	SIC/SIC EPDM	ANGA, SD: 45mm	
21649	D4	TuC/TuCKE FKM	ANGA, SD: 45mm	
22039	D4	TuC/TuCKE EPDM	ANGA, SD: 45mm	
22139	DX3	SIC/SIC_TuC/Tu-CKE/FKM	ANGA, SD: 45mm	
22138	DX3	SIC/SIC_TuC/Tu-CKE/EPDM	ANGA, SD: 45mm	
<b>NOTES:</b>				

Mechanical Seal DAMS_VT104_G8+, NG				Pos. 2535
Part #	CUSTOMER REFERENCE #	Material	Specification	
22045	D1	SIC/SIC FKM	HUHNSEAL, SD: 42mm	
22044	D1	SIC/SIC EPDM	HUHNSEAL, SD: 42mm	
21692	D2	TuC/TuCKE FKM	HUHNSEAL, SD: 42mm	
21566	D2	TuC/TuCKE EPDM	HUHNSEAL, SD: 42mm	
<b>NOTES:</b>				

5.2.3 Spare Parts for Bearing Housing

Key for Coupling_VT104_G7, G8+, NG				Pos. 1183
Part #	CUSTOMER REFERENCE #	Material	Specification	
12618		304	DIN6885-AS 8x7x32	
<b>NOTES:</b>				

Shaft Sealing Ring Bearing Housing_VT104_G8+, NG				Pos.2322
Part #	CUSTOMER REFERENCE #	Material	Specification	
21763		FKM	DIN3760-AS 50x72x8	
<b>NOTES:</b>				

Dowel Pin for Seal Housing Alignment_VT104, VT130_G8+, NG				Pos. 2536
Part #	CUSTOMER REFERENCE #	Material	Specification	
21903		304	DIN7-8h8x24	
<b>NOTES:</b>				

5.2.4 Spare Parts for Gear Housing

Shaft Sealing Ring Gear Housing_VT104_G8+, NG				Pos. 1010
Part #	CUSTOMER REFERENCE #	Material	Specification	
21905		FKM	DIN3760-AS-32x52x7, SD: 45mm	
<b>NOTES:</b>				

Magnetic Screw Plug_VT70, VT104, VT130_G8+, NG				Pos. 2233
Part #	CUSTOMER REFERENCE #	Material	Specification	
21767		Alum.	DIN910, Size G3/4"	
23114		FKM	Pos. 2360, Gasket for Sight Gauge and Magnetic Screw Plug, 5 Pack	
<b>NOTES:</b>				

Oil Level Sight Gauge_VT70, VT104, VT130_G8+, NG				Pos. 2360
Part #	CUSTOMER REFERENCE #	Material	Specification	
21766		Aluminum Glass	Size G3/4"	
23114		FKM	Pos. 2360, Gasket for Sight Gauge and Magnetic Screw Plug, 5 Pack	
<b>NOTES:</b>				

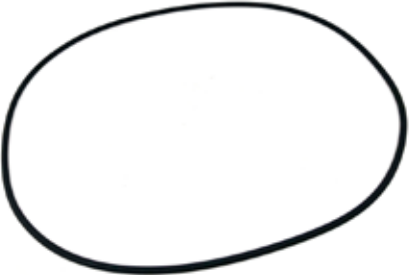
O-Ring Large for Gear Housing_VT104_G8+, NG				Pos. 2513
Part #	CUSTOMER REFERENCE #	Material	Specification	
21764		FKM	DIN3771-237x4,0	
<b>NOTES:</b>				

O-Ring Small for Gear Housing_VT104_G8+, NG				Pos. 2514
Part #	CUSTOMER REFERENCE #	Material	Specification	
21765		FKM	DIN3771-18,5x2,0	
<b>NOTES:</b> Sold in sets of 4.				

Gear Oil Bearing Housing VT				
Part #	CUSTOMER REFERENCE #	Material	Specification	
21871		--	1 Liter	
<b>NOTES:</b>				

5.2.5 Spare Parts for Drive Train

Coupling Hub Pump_VT104_G8+, NG				Pos. 2247
Part #	CUSTOMER REFERENCE #	Material	Specification	
21702		Alum.	BS: 28mm, SIT	
<b>NOTES:</b>				

Coupling Hub Motor_VT104_G8+, NG				Pos. 2248
Part #	CUSTOMER REFERENCE #	Material	Specification	
21704		Alum.	BS: 1-3/8"	
21705		Alum.	BS: 1-5/8"	
21706		Alum.	BS: 1-7/8"	
21707		Alum.	BS: 2-1/8"	
22196		Alum.	BS: 2-3/8"	
<b>NOTES:</b> Size might change due to motor size. Please consult configuration key or contact Processtec Inc.				

Coupling Spider_VT104, VT130_G8+, NG				Pos. 2249
Part #	CUSTOMER REFERENCE #	Material	Specification	
7115		PU	98 42/55-Red, SIT	
<b>NOTES:</b>				

Coupling Hub Pump_VT104_G8+, NG				Pos. 2247
Part #	Material	Size	Specification	
23178	STO	--	SD: 28mm, R+W	
<b>NOTES:</b>				

Coupling Hub Motor_VT104_G8+, NG				Pos. 2248
Part #	Material	Size	Specification	
23241	Aluminum	--	SD: 1-3/8" R+W	
23237	Aluminum		SD: 1-5/8" R+W	
23236	Aluminum		SD: 1-7/8" R+W	
23176	Aluminum		SD: 2-1/8" R+W	
<b>NOTES:</b> Size might change due to motor size. Please consult configuration key or contact <b>PROCESSTEC</b> .				

Coupling Spider_VT104, VT130_G8+, NG				Pos. 2249
Part #	Material	Size	Specification	
23243	TPU	--	Servomax EK-150, R+W	
<b>NOTES:</b>				

W22 Severe Duty Motor				Pos. 3003
Part #	Material	Size	Pump Generation	
--	Cl	--	variable	
<p><b>NOTES:</b> WEG Severe Duty 25 HP. Size might change due to application requirements.</p>				

5.3 Explosion Drawings

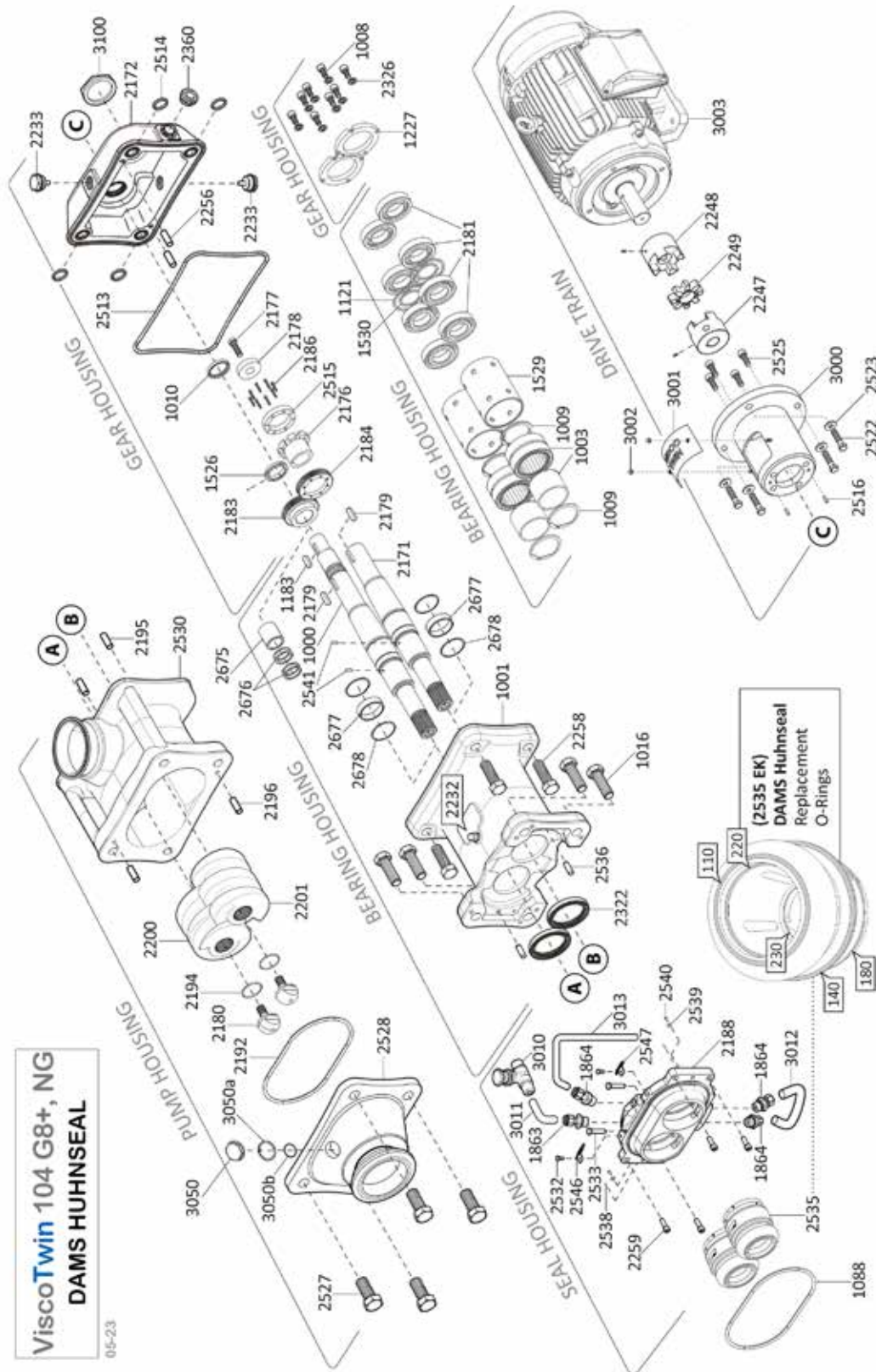



5.4 Torque Tables

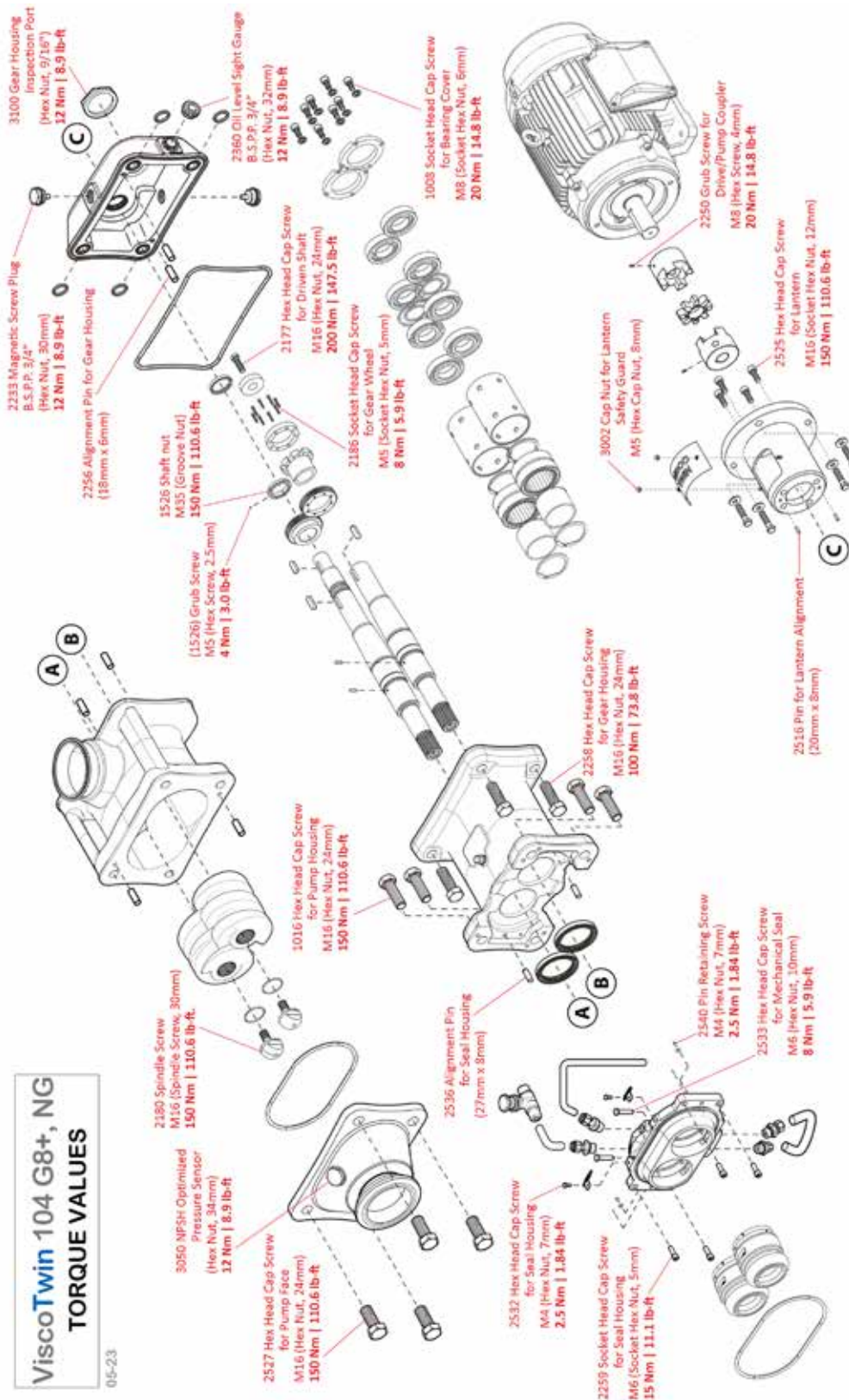

**ViscoTwin 104 G8+, NG**  
**TORQUE VALUES**  
05-23

**Tabloid Size**  
(11" x 17")

**5.5 Pump Housing Configuration**

Each ViscoTwin 104 G8+, NG Pump Housing can be set up for a variety of configuration options to suit particular application.

Each Configuration has been uniquely identified with a series of letters and numbers that call out the specific flow direction, shaft rotation, pin positions and spindle arrangements to get the desired output.

For example, a FHO3V configuration means that the Flow Direction is Face In/Housing Out (FH), Shaft Rotation is Outward (O). Pin Position is Configuration 3 (3) with Spindle Arrangement V (V).

There are SIX possible configurations, and each one is listed in the chart below, as well on the following pages. The default configuration is FHO3V.

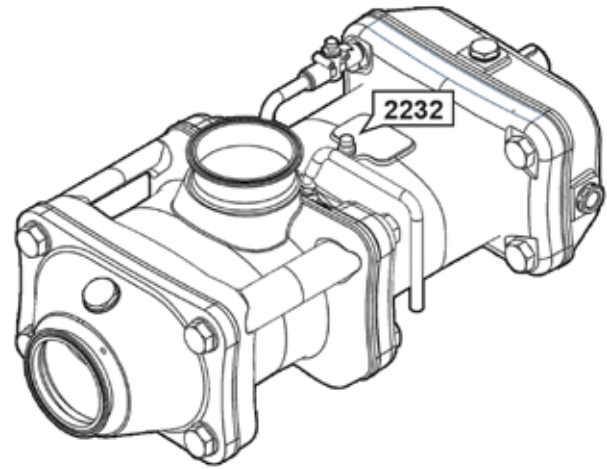

The TOP of the pump is always determined by the location of the VENT Plug (Pos. 2232) on the Bearing Housing, regardless of the Pump Housing orientation and the final position of the Pump.

CONFIGURATION NAME	FLOW DIRECTION	SPINDLE ROTATION	PIN POSITION	SPINDLE ARRANGEMENT	COMMENTS
<b>FHO3V</b>	Face In / Housing Out	Outwards	3	V	Product dragged along the bottom
<b>FHI1A</b>	Face In / Housing Out	Inwards	1	A	Product dragged along the top
<b>HFI1V</b>	Housing In / Face Out	Inwards	1	V	Product dragged along the top
<b>HFO3A</b>	Housing In / Face Out	Outwards	3	A	Product dragged along the bottom
<b>BDB2V</b>	Bi-Directional	Bi-Directional	2	V	Limited Viscosity Tapered Spindles Preferred
<b>BDB2A</b>	Bi-Directional	Bi-Directional	2	A	Limited Viscosity Tapered Spindles Preferred

Flow Direction (figure 1)

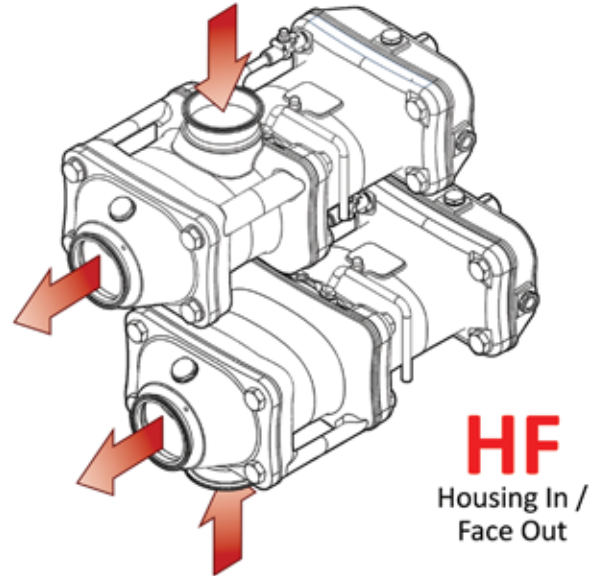
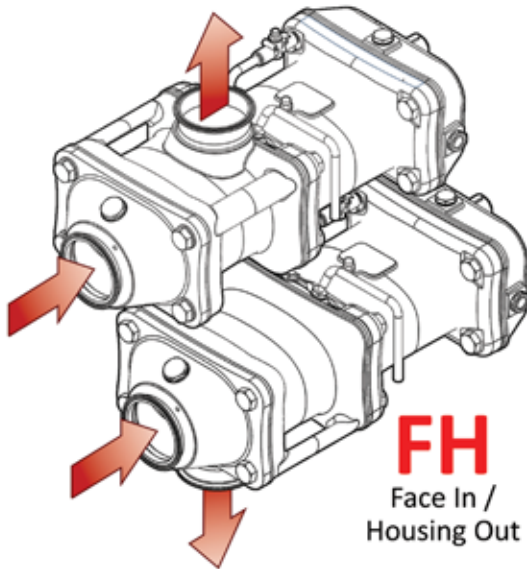

Shaft Rotation (figure 2)

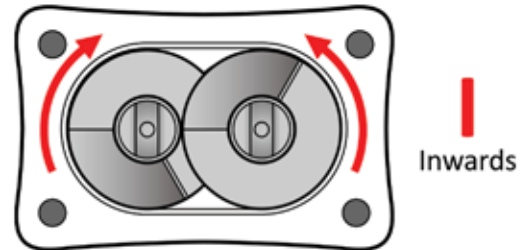
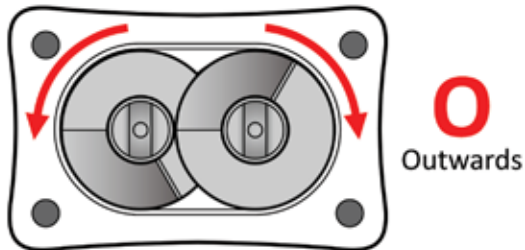

Pin Configuration (figure 3)

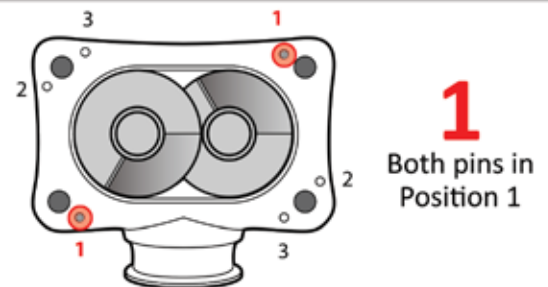
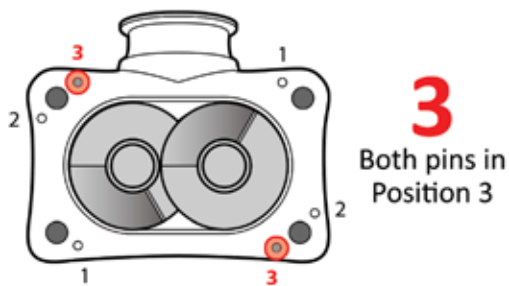

Spindle Arrangement (figure 4)

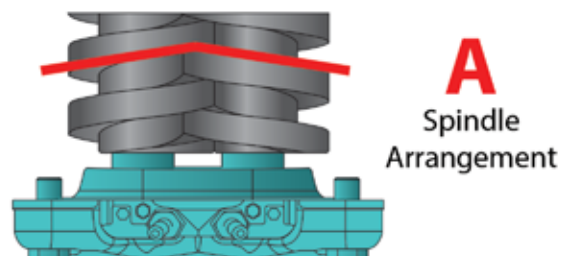
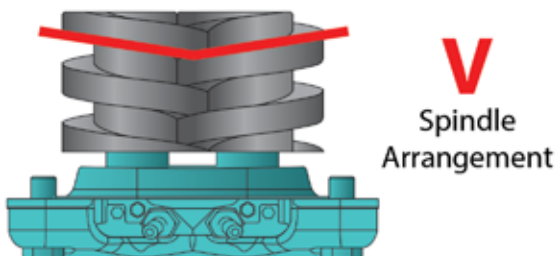

## FHO3V (T)

FH - Face In / Housing Out  
O - Outwards  
3 - Pin Position 3  
V - Spindle Arrangement V  
T - Top

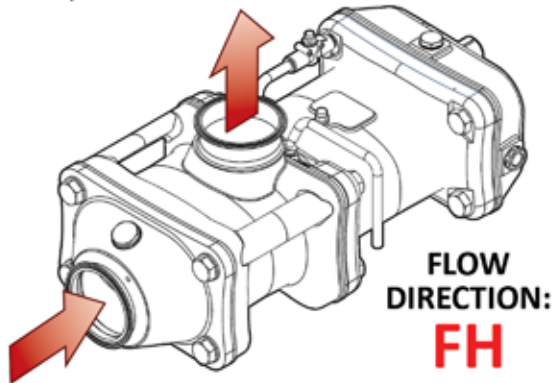

FLOW  
DIRECTION:  
**FH**

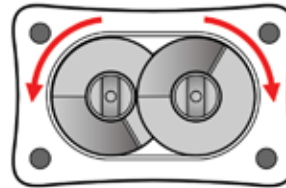

SHAFT ROTATION:  
**OUTWARDS**  
requires clearance on the top

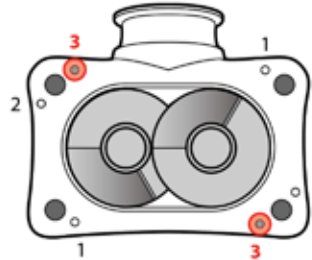

PIN CONFIGURATION:  
**3**  
delivers clearance on the top

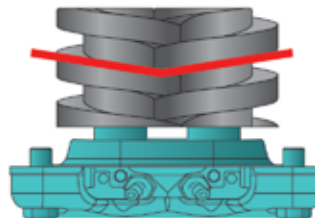

SPINDLE  
ARRANGEMENT:  
**V**

## FHO3V (B)

FH - Face In / Housing Out  
O - Outwards  
3 - Pin Position 3  
V - Spindle Arrangement V  
B - Bottom

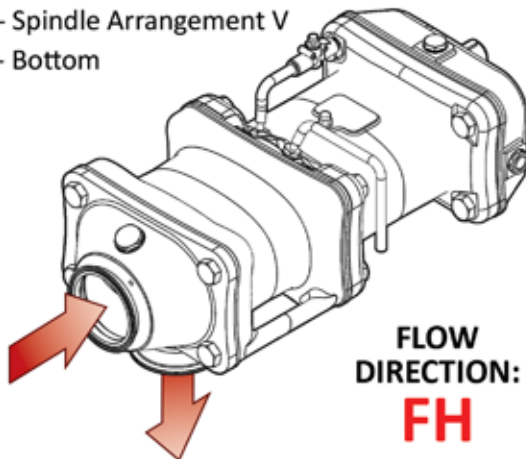

FLOW  
DIRECTION:  
**FH**

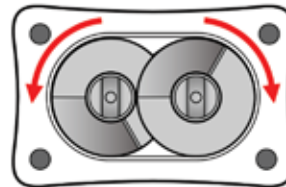

SHAFT ROTATION:  
**OUTWARDS**  
requires clearance on the top

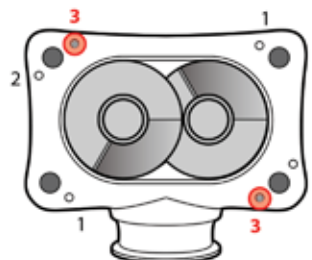

PIN CONFIGURATION:  
**3**  
delivers clearance on the top

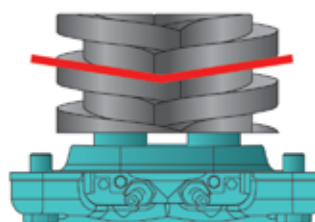

SPINDLE  
ARRANGEMENT:  
**V**

## FHI1A (T)

FH - Face In / Housing Out  
I - Inwards  
1 - Pin Position 1  
A - Spindle Arrangement A  
T - Top

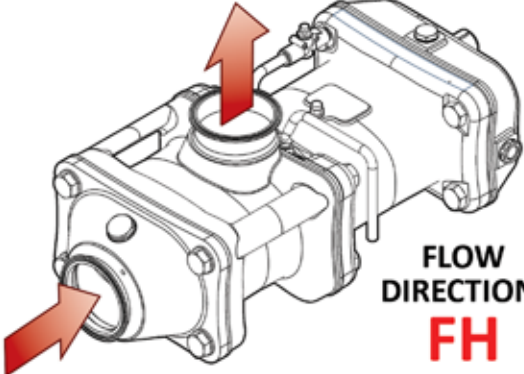

**FLOW DIRECTION:**  
**FH**

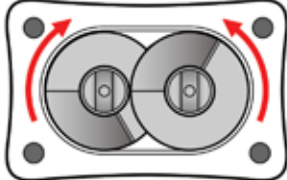

**SHAFT ROTATION:**  
**INWARDS**  
requires clearance on bottom

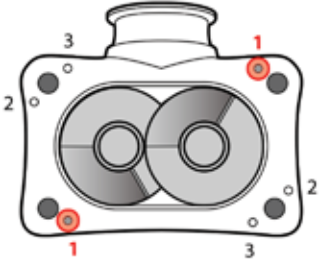

**PIN CONFIGURATION:**  
**1**  
delivers clearance on bottom



**SPINDLE ARRANGEMENT:**  
**A**

## FHI1A (B)

FH - Face In / Housing Out  
I - Inwards  
1 - Pin Position 1  
A - Spindle Arrangement A  
B - Bottom

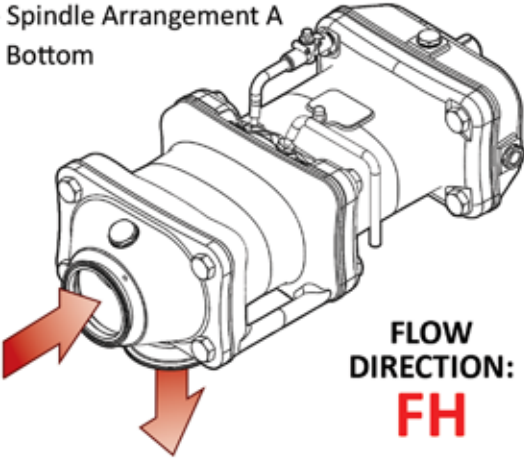

**FLOW DIRECTION:**  
**FH**

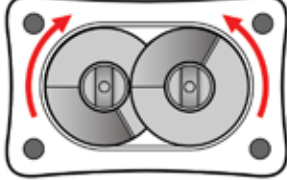

**SHAFT ROTATION:**  
**INWARDS**  
requires clearance on bottom

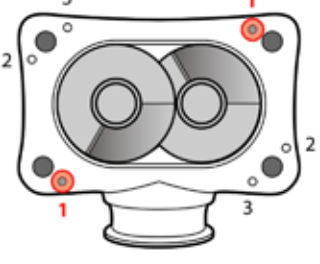

**PIN CONFIGURATION:**  
**1**  
delivers clearance on bottom



**SPINDLE ARRANGEMENT:**  
**A**

## HFI1V (T)

HF - Housing In / Face Out  
I - Inwards  
1 - Pin Position 1  
V - Spindle Arrangement V  
T - Top

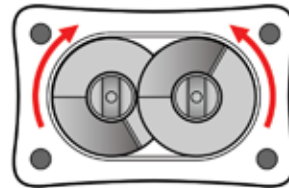
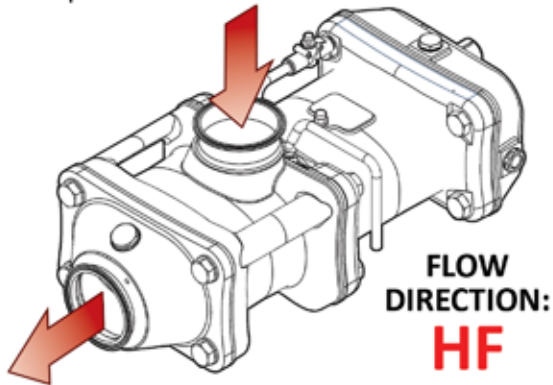

SHAFT ROTATION:  
**INWARDS**  
requires clearance on bottom

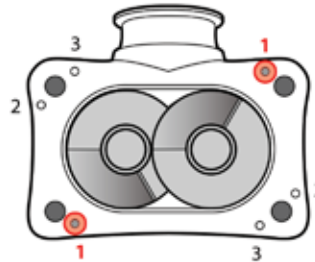

PIN CONFIGURATION:  
**1**  
delivers clearance on bottom

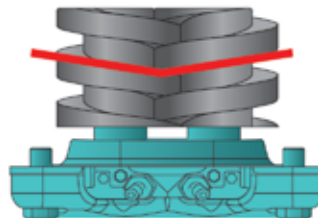

SPINDLE  
ARRANGEMENT:  
**V**

## HFI1V (B)

HF - Housing In / Face Out  
I - Inwards  
1 - Pin Position 1  
V - Spindle Arrangement V  
B - Bottom

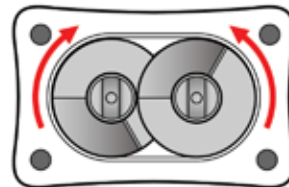
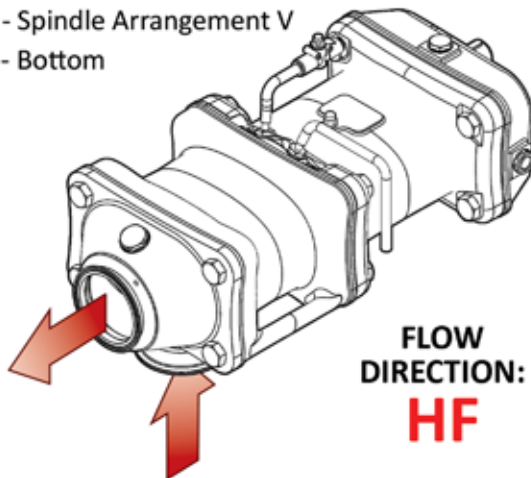

SHAFT ROTATION:  
**INWARDS**  
requires clearance on bottom

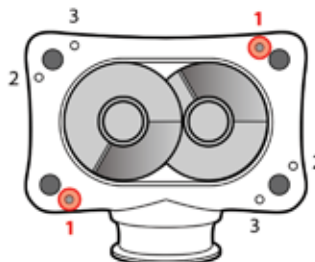

PIN CONFIGURATION:  
**1**  
delivers clearance on bottom

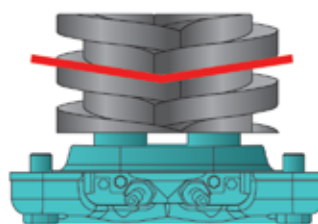

SPINDLE  
ARRANGEMENT:  
**V**

## HFO3A (T)

HF - Housing In / Face Out  
O - Outwards  
3 - Pin Position 3  
A - Spindle Arrangement A  
T - Top

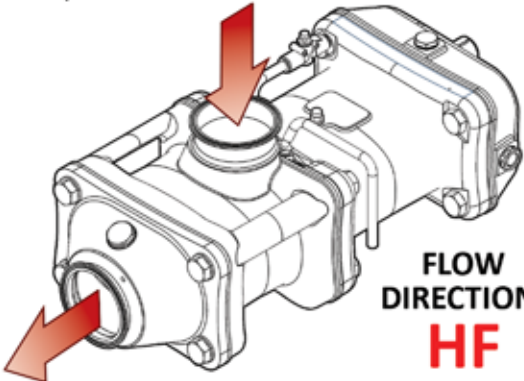

**FLOW DIRECTION:**  
**HF**

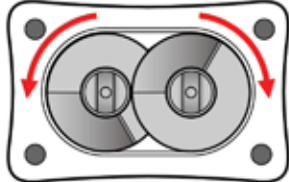

**SHAFT ROTATION:**  
**OUTWARDS**  
requires clearance on the top

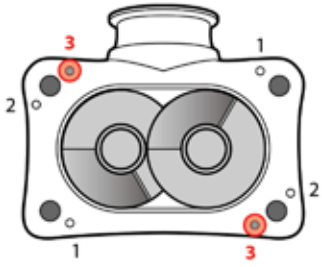

**PIN CONFIGURATION:**  
**3**  
delivers clearance on the top



**SPINDLE ARRANGEMENT:**  
**A**

## HFO3A (B)

HF - Housing In / Face Out  
O - Outwards  
3 - Pin Position 3  
A - Spindle Arrangement A  
B - Bottom

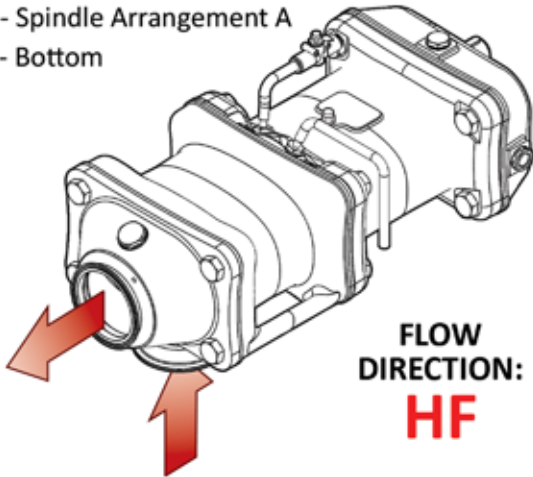

**FLOW DIRECTION:**  
**HF**

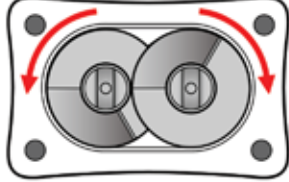

**SHAFT ROTATION:**  
**OUTWARDS**  
requires clearance on the top



**PIN CONFIGURATION:**  
**3**  
delivers clearance on the top



**SPINDLE ARRANGEMENT:**  
**A**

## BDB2V (T)

BD - Bi-Directional  
B - Bi-Directional  
2 - Pin Position 2  
V - Spindle Arrangement V  
T - Top

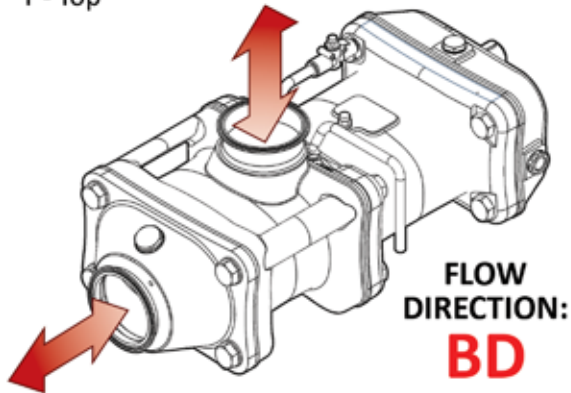

FLOW  
DIRECTION:  
**BD**

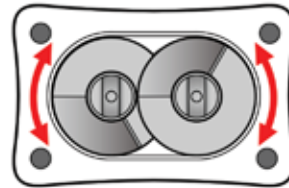

SHAFT ROTATION:  
**BI-DIRECTIONAL**  
evenly distributed clearance

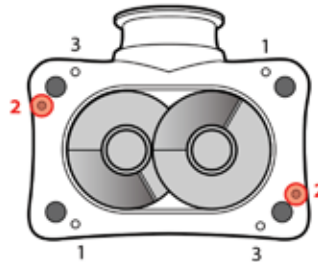

PIN CONFIGURATION:  
**2**  
evenly distributed clearance

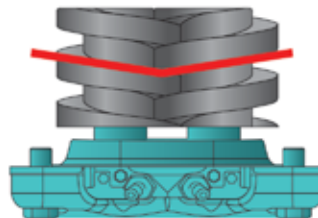

SPINDLE  
ARRANGEMENT:  
**V**

## BDB2V (B)

BD - Bi-Directional  
B - Bi-Directional  
2 - Pin Position 2  
V - Spindle Arrangement V  
B - Bottom

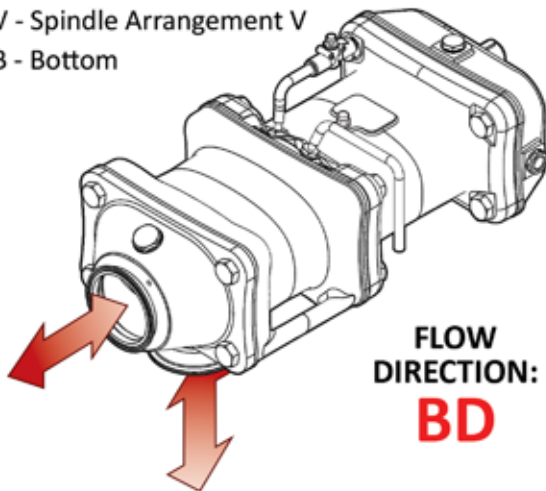

FLOW  
DIRECTION:  
**BD**

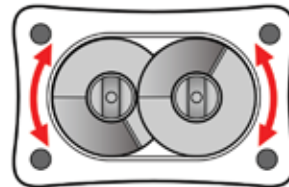

SHAFT ROTATION:  
**BI-DIRECTIONAL**  
evenly distributed clearance

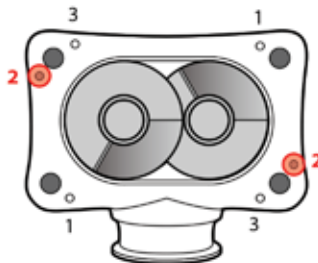

PIN CONFIGURATION:  
**2**  
evenly distributed clearance

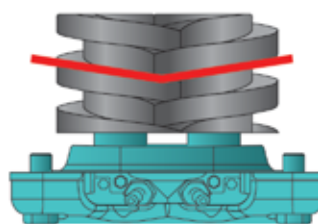

SPINDLE  
ARRANGEMENT:  
**V**



### BDB2A (T)

BD - Bi-Directional  
B - Bi-Directional  
2 - Pin Position 2  
A - Spindle Arrangement A  
T - Top

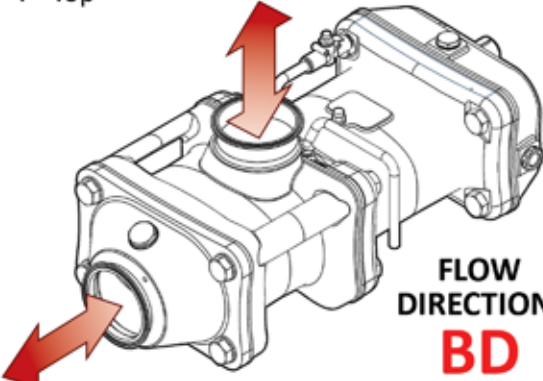

**FLOW DIRECTION: BD**

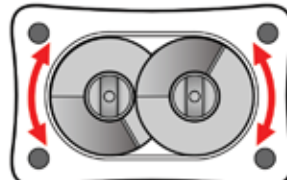

**SHAFT ROTATION: Bi-DIRECTIONAL**  
evenly distributed clearance

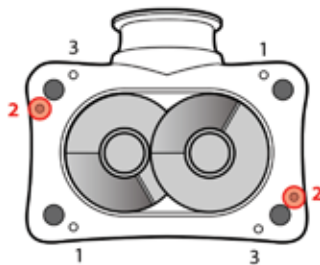

**PIN CONFIGURATION: 2**  
evenly distributed clearance

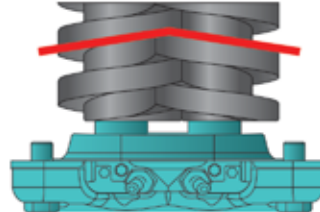

**SPINDLE ARRANGEMENT: A**

### BDB2A (B)

BD - Bi-Directional  
B - Bi-Directional  
2 - Pin Position 2  
A - Spindle Arrangement A  
B - Bottom

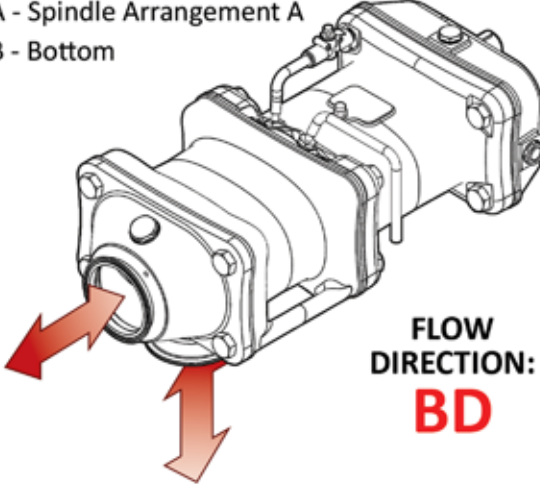

**FLOW DIRECTION: BD**

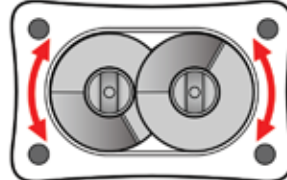

**SHAFT ROTATION: Bi-DIRECTIONAL**  
evenly distributed clearance

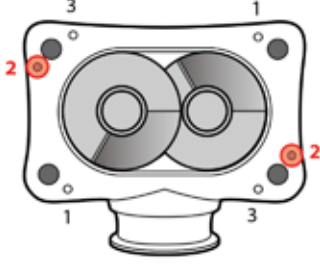

**PIN CONFIGURATION: 2**  
evenly distributed clearance



**SPINDLE ARRANGEMENT: A**

## 5.6 Oils, Grease & Lubrication Recommended

### Lubricating Bearings and Gear Wheels

There are a few options for gear wheel lubrication in the Pump / Bearing Housing of the **ViscoTwin 104 G8+, NG:**

**Polyglycol based** (can absorb up to 3% water)

- Klubersynth

**Polyalphaolefin based** (cannot absorb water)

- Jax-68
- Castrol Optileb
- Lubriplate SFGO Ultra 220

As a general rule, thinner oil is more frequently used in colder areas, and thicker oil is use in warmer areas. A higher number next to the oil indicates a thicker oil, while a lower number indicates a thinner oil.

**150 = thicker**  
**68 = thinner**

Jax-68 is used very commonly in the United States of America, where **Processtec** is located.

VT-Diagramm

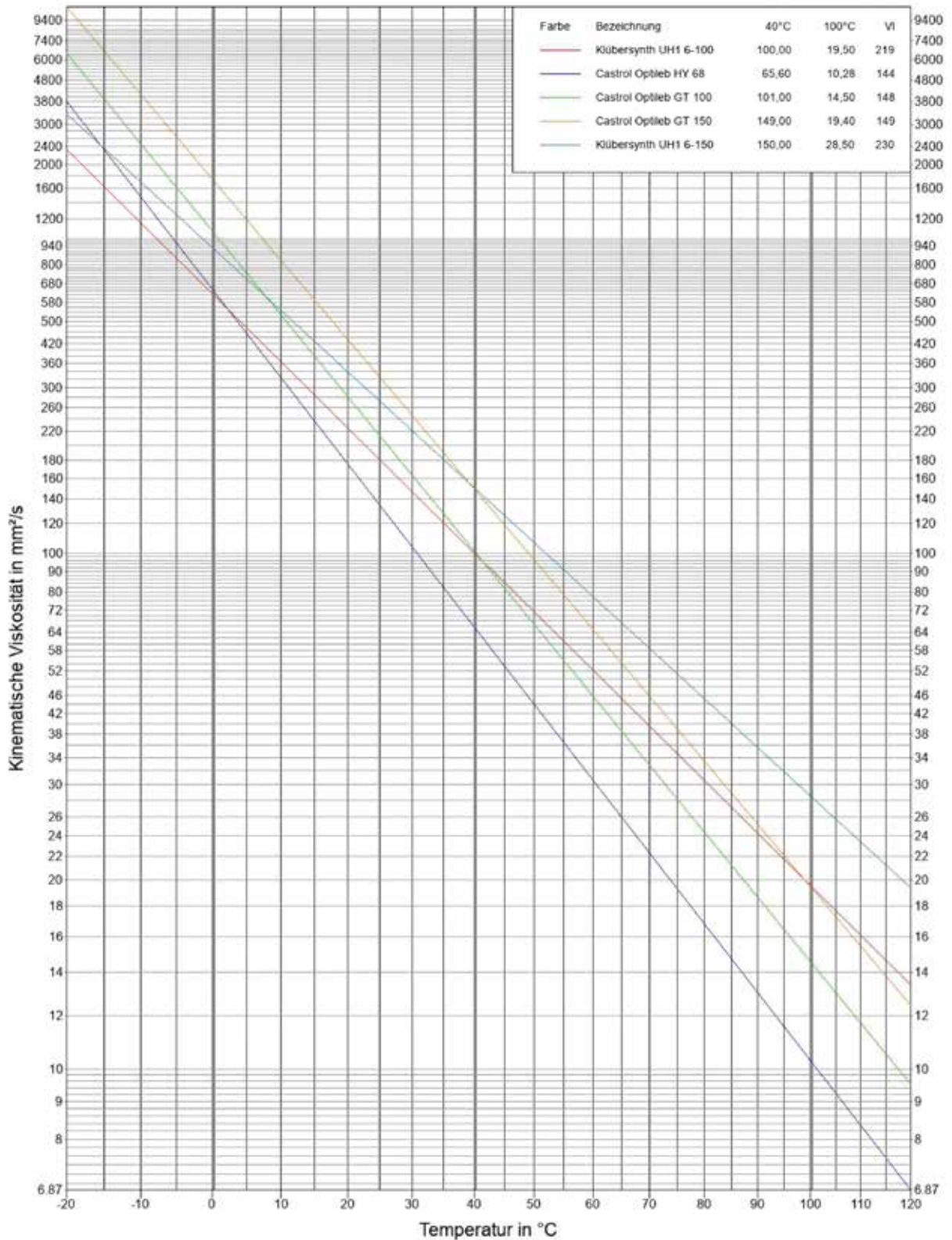

### **5.7 Oil Testing Kit (with Form)**

Please talk with your oil supplier about an Oil Testing Kit so that you can check and maintain the integrity of the pump oil.

*This page intentionally left blank.*

## 6. GEEK'S CORNER

### 6.1 Oil Cooler with Oil Filter

In case very hot product is pumped, the heat can sometimes penetrate through the shaft to the needle bearings, and shaft seals (Pos. 2322). It is strongly recommended to install an oil cooler to maintain the oil temperature at the needle bearings at max 212° F (100° C).

Processtec's customized oil cooling system for ViscoTwin pumps is shown below.

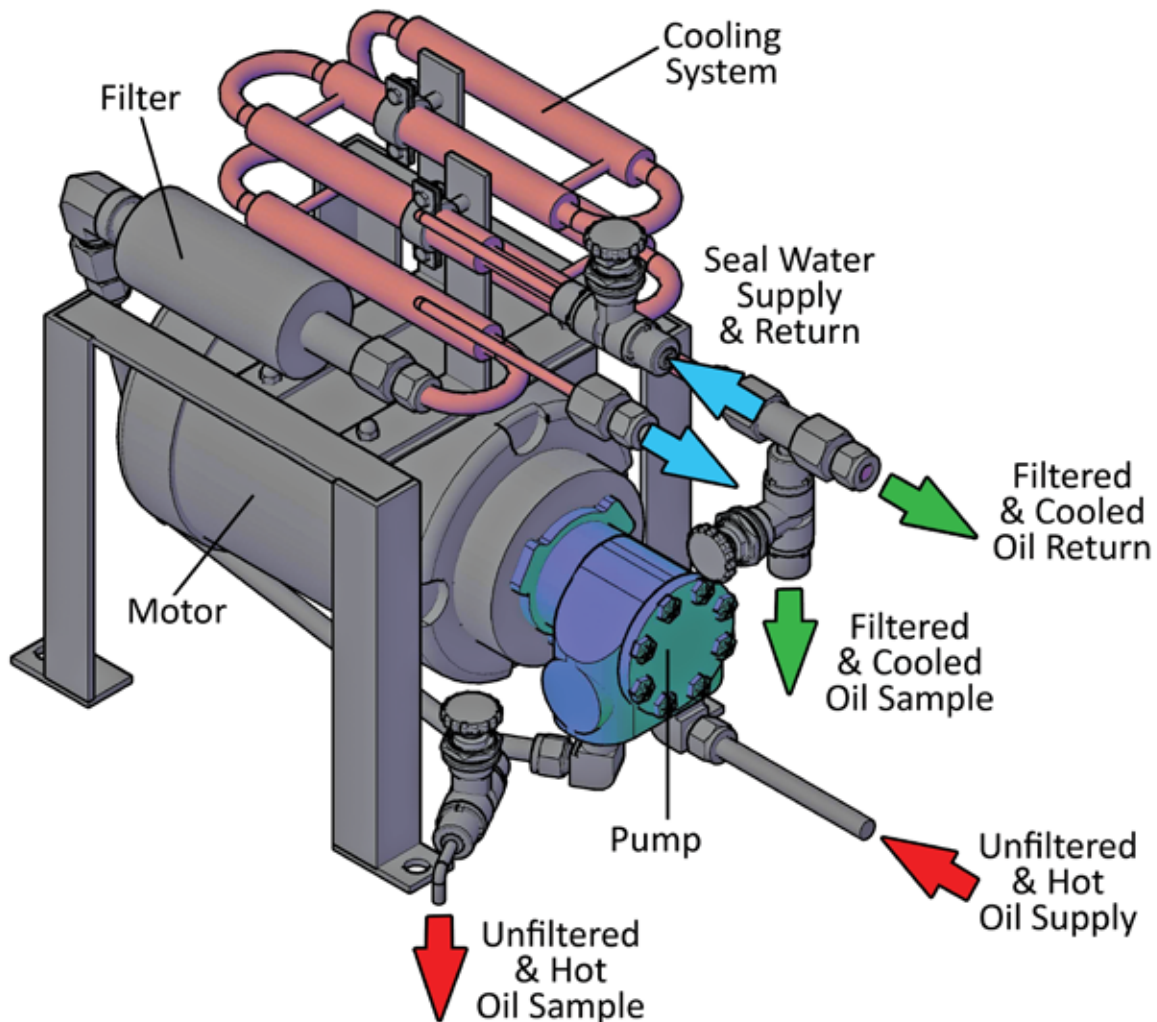

## 6.2 Vibration Sensor with Oil Temperature Sensors

**Processtec**, along with GEPA Engineering, is testing a customized solution to accurately sense the harmonics of **ViscoTwin** pumps. This will allow the pump's bearing to be monitored continuously.

Especially for high pressure applications where high axial forces dramatically limit the bearing lifespan, vibration monitoring will prevent unexpected downtime with planable preventative maintenance, making **ViscoTwin** high pressure pump setups a highly sustainable solution.

**6.3 Quench Design for Recirculating Fluids in Mechanical Seals**

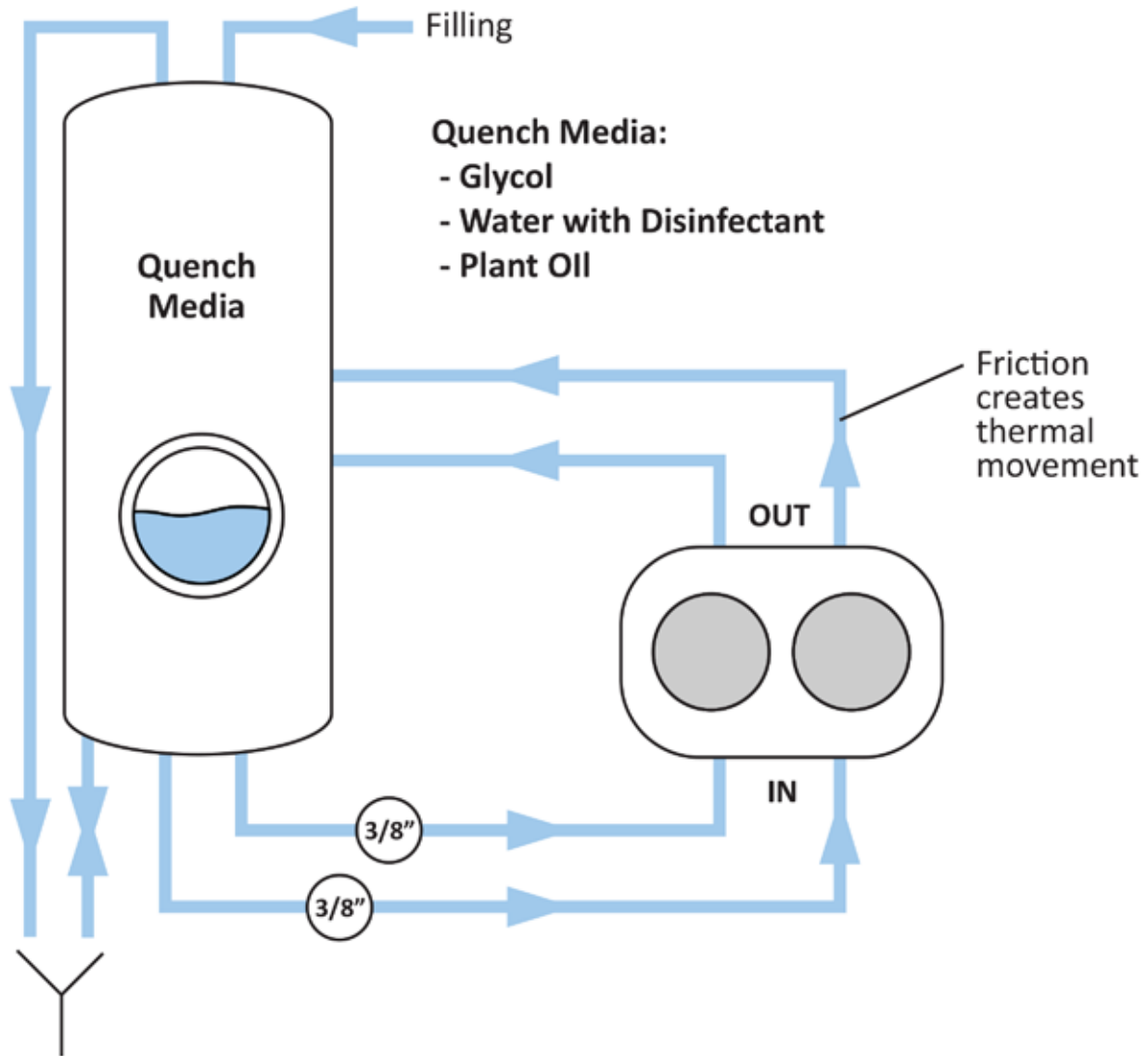



## 6.4 Maximizing Bearing Lifespan

### The Importance of Bearing Lifespan

Bearings are a key element to sustained pump operation. Throughout the lifespan of any pump, the bearings experience the majority of operation based wear and tear and are often the first point of failure. Without regular bearing maintenance, mechanical failure becomes inevitable. This leads to complications and consequences to further pump operation as well as significant losses in production from maintenance downtime. Bearing lifespan is an important tool in maximizing lifespan across the system as well as avoiding costly repairs.

### Bearing Types Across ViscoTwin Pump Line

Pump	Ball Bearing ( SKF )	Needle Bearing ( FAG / KOYO )	Applicable Area of the Top of the Spindle	Applicable Area of the Front of the Spindle
VT-70	7305 BECBM	NKJ 40/30	0.0037 m <sup>2</sup>	0.0050 m <sup>2</sup>
VT-104	7207 BECBM	NA 6910	0.0060 m <sup>2</sup>	0.0079 m <sup>2</sup>
VT-130	7209 BECBM	NA 6912	0.0113 m <sup>2</sup>	0.0133 m <sup>2</sup>

Table 1: ViscoTwin Pump Bearing Configuration

The **Processtec** line of **ViscoTwin G8+, NG** pumps are equipped with two different types of bearings in varying configurations, each with their own specifications. All bearings used in **ViscoTwin** pumps are produced by SKF high-performance bearings with the exception of the needle bearing used in the Model VT-70, produced by KOYO.

### Measured Impact of Each Variable

#### Introduction

The following analysis was performed on a standard 7207 BECBY bearing in a test by SKF high-performance bearings. The constants for the models are as follows:

<b>Pump:</b> VT-104	<b>r/min:</b> 1500
<b>Direction:</b> Front in / Top Out	<b>Number of bearings in Tandem:</b> 2 sets of 2 bearings in tandem
<b>Exit Pressure:</b> 25 bar	<b>Axial Load per Bearing:</b> 7 kN
<b>Supply Pressure:</b> 2 bar	<b>Operating Temperature:</b> 80° C
<b>Radial Load:</b> 3 kN	<b>Nc specifications:</b> Slight-typical contamination
<b>Total Axial Load:</b> 14 kN	<b>Lubrication Viscosity:</b> 100 mm <sup>2</sup> /s @ 40° C and 40 mm <sup>2</sup> /s @ 100° C

## Effective Variables in Bearing Lifespan

### Mounting Arrangement

Processtec installs bearings in tandem to allow bearings to share the load evenly and reduce stress. This drastically extends the lifespan of bearings due to the force reduction by a factor of 'n', where 'n' is the number of bearings mounted in tandem with the force exerted on the bearing in both radial and axial dimensions.

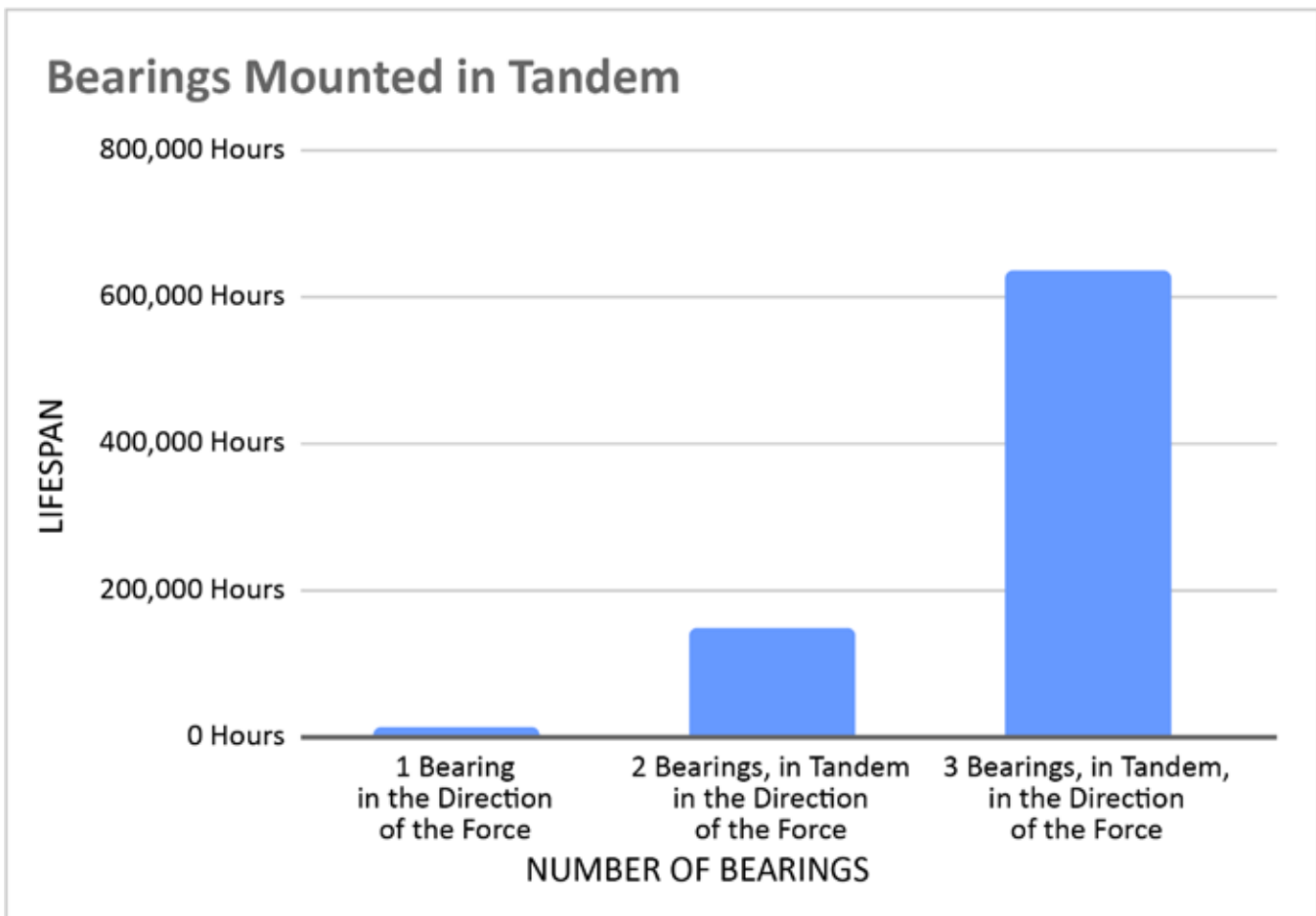

### Oil Cleanliness

During pump operation, friction tears particles from the exterior of the balls and rollers. These particles then accumulate in the oil, exponentially increasing the wear on the bearings as well as increasing the bearing operating temperature due to friction. For these reasons, it is vital to check the bearing oil regularly for the particulates and replace the oil as necessary. All **ViscoTwin** pumps come standard with two magnetic plugs to help collect and trap particulates, keeping the oil cleaner for longer.

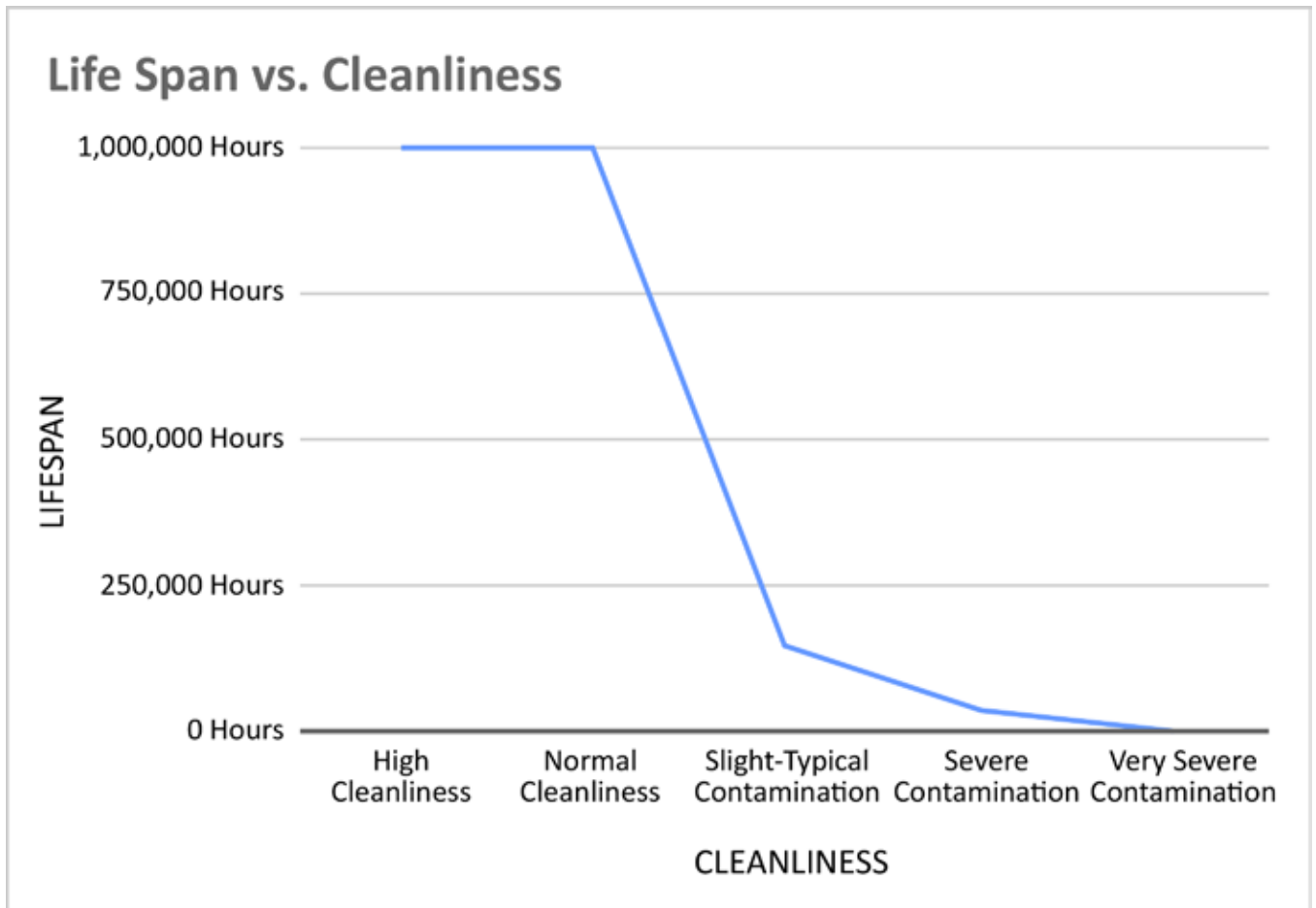

## Bearing Quality

If a bearing fails to meet industry standards, it will be unable to distribute force on the rollers/balls evenly. Failing to meet these standards will not only create metal particles in the oil and increase operating temperature, it could also imbalance the pump shaft. It is essential that the pumps only use high-quality bearings with tight tolerances.

To ensure your bearing is functioning correctly, check the following things:

- All roller balls are present in the ball bearing.
- When rotated, all rollerballs make contact with both surfaces and roll and don't slip.
- Make sure there is very little play when holding the exterior ring and applying force to the side with the larger interior ring.
- Look for perfectly round roller balls. Any discoloration and dents can be a sign of a bad bearing.

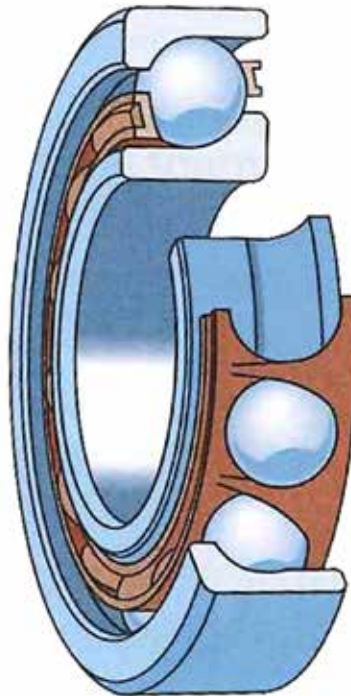

### Oil Operating Temperature

As the bearings change temperature, they both expand and experience thermal shock, both of which serve to increase bearing wear and tear. With the rise in operating temperature, the oil also begins to thin, providing less lubrication for the bearings.

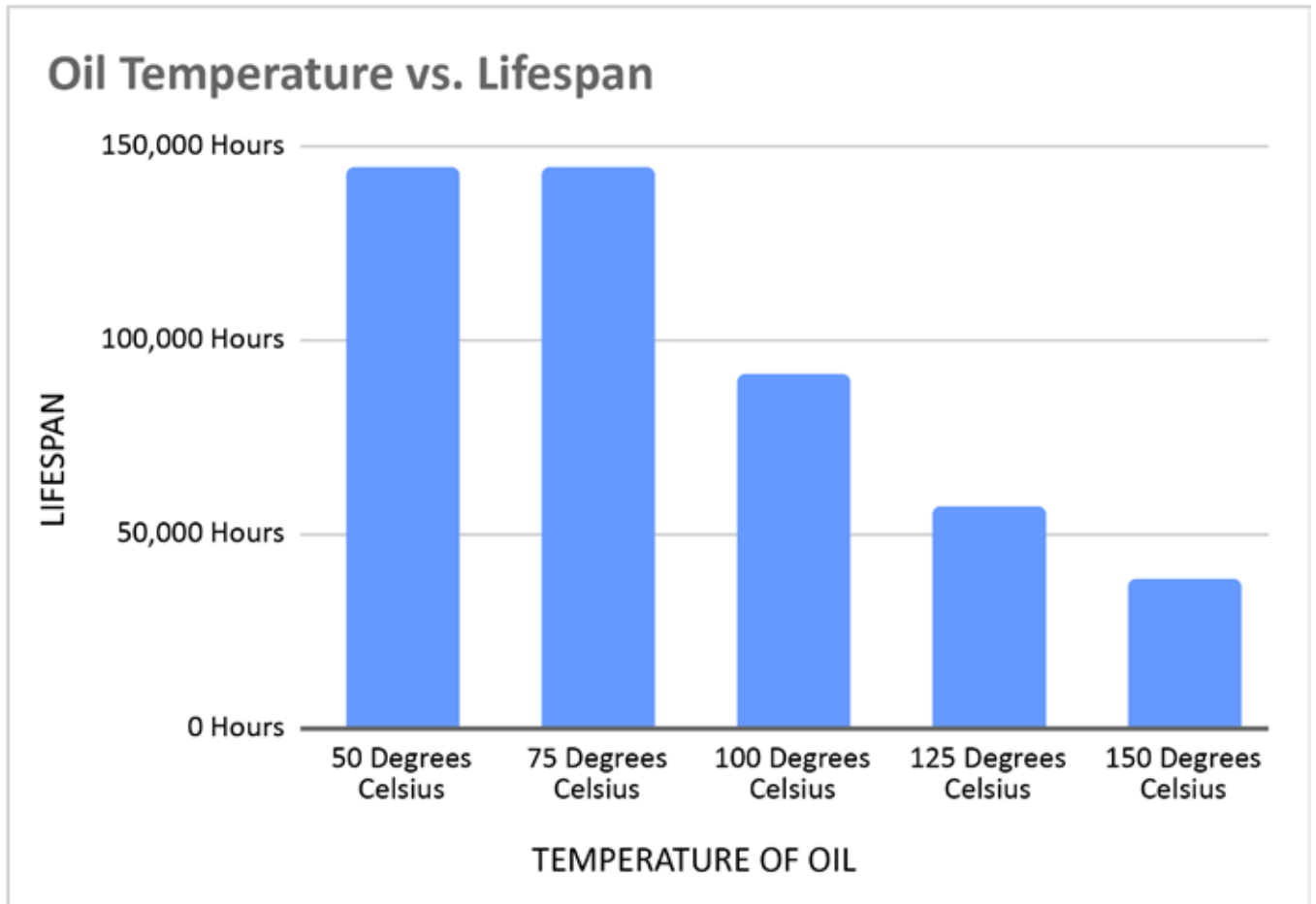

**Oil Thickness**

High viscosity oils are more effective at lubricating bearings. They reduce friction between the balls and the outer casing, thus reducing both heat generation and damage caused by parts contacting.

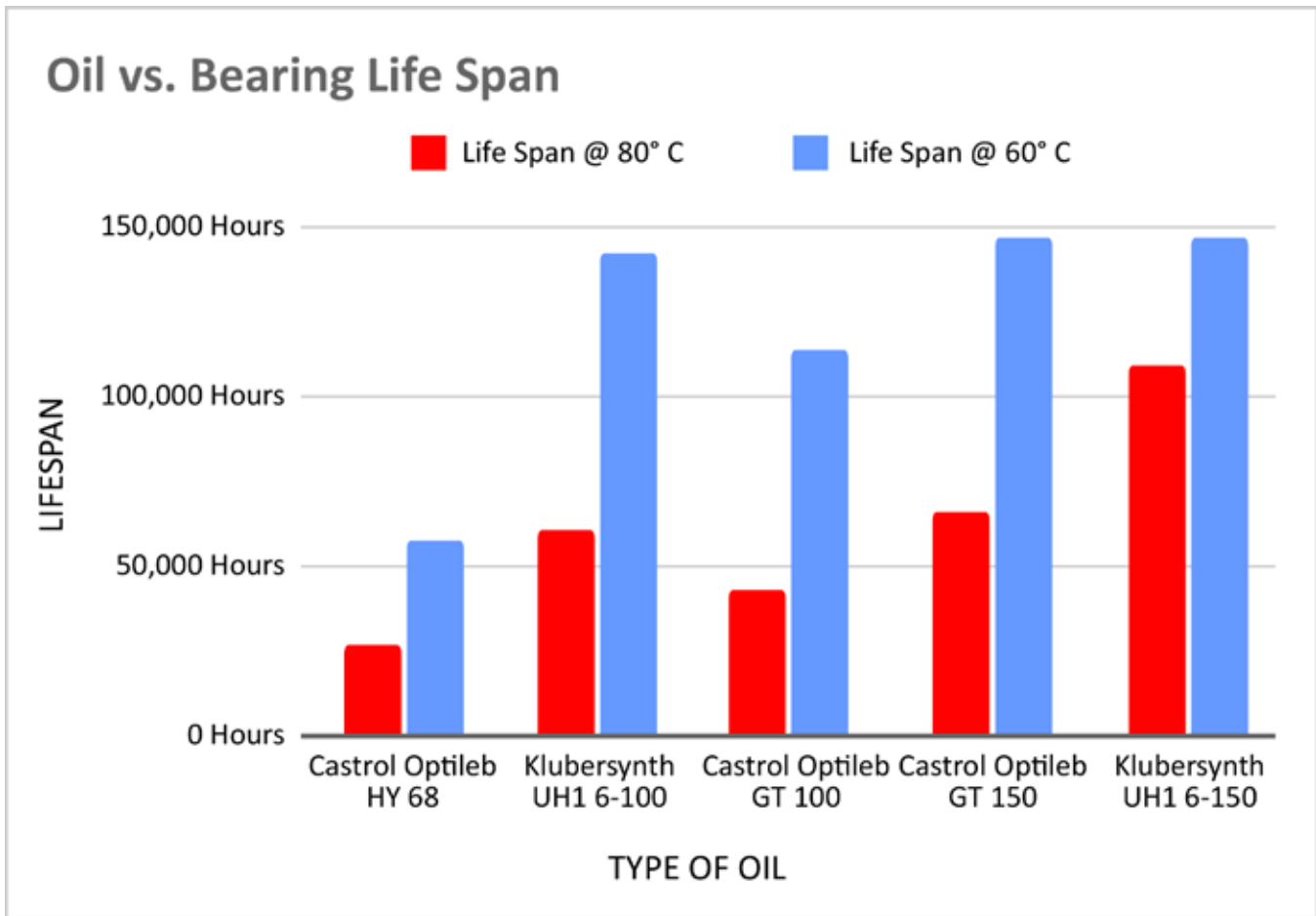

### Rotation Per Minute

Increasing the RPM's forces each bearing to travel farther and faster over time, increasing the heat produced and damage each bearing will accumulate versus the same bearings being used at lower RPM's over the same time. Furthermore, the RPM's limits the effectiveness of more viscous oils due to the increased resistance from moving through thick oil, outweighing the benefits of more viscous oil.

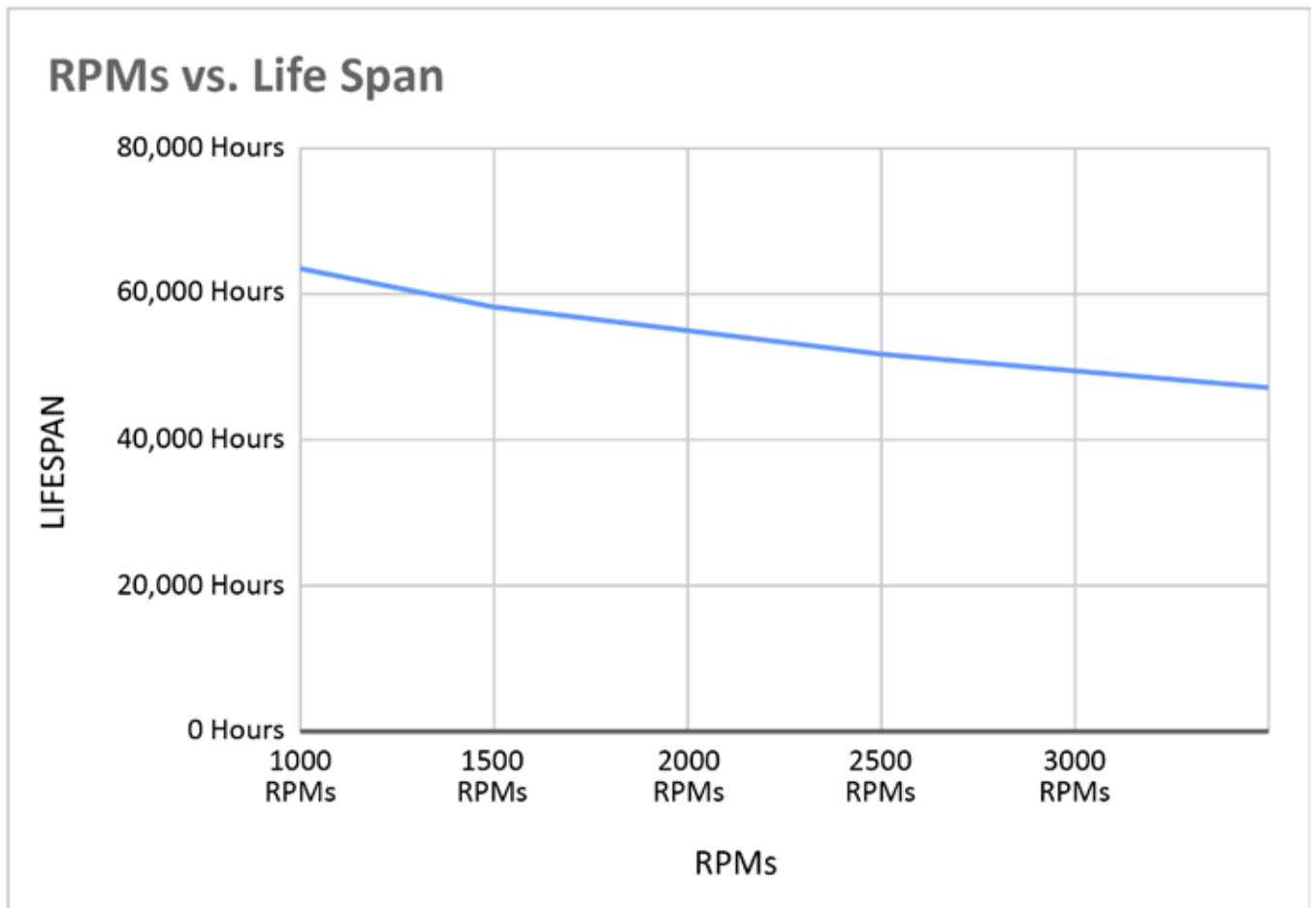

Reference Page

Pump Diagram HF (Housing In, Face Out)

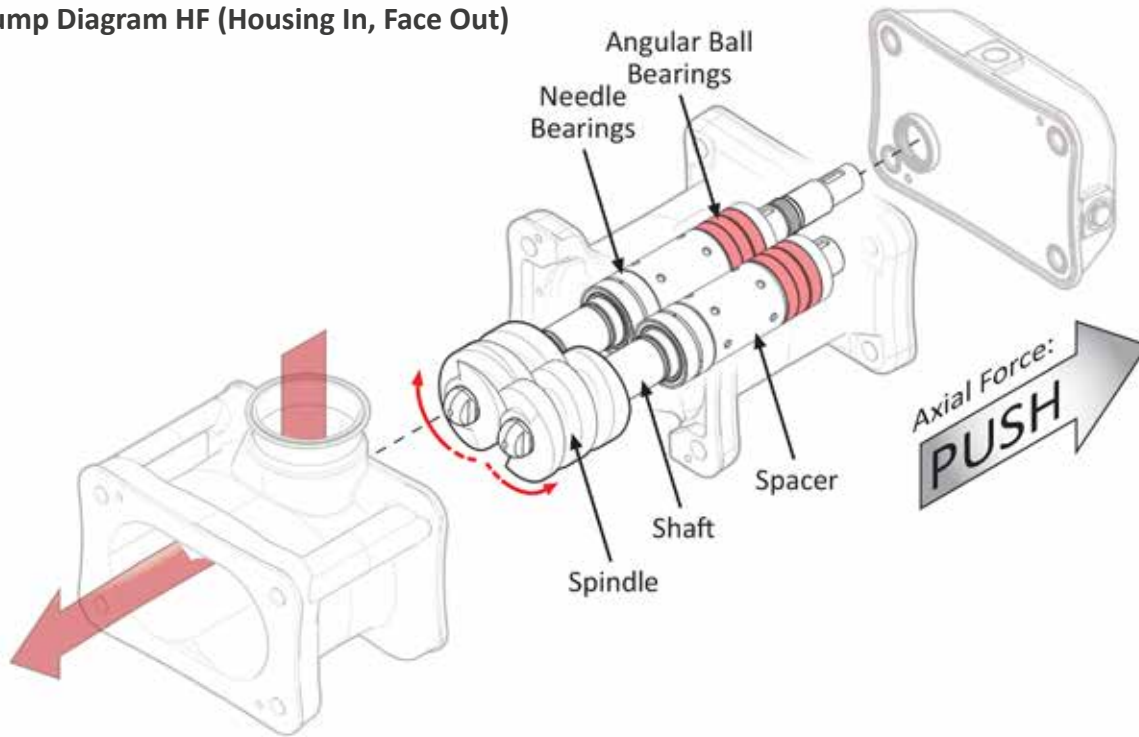

Pump Diagram FH (Face In, Housing Out)

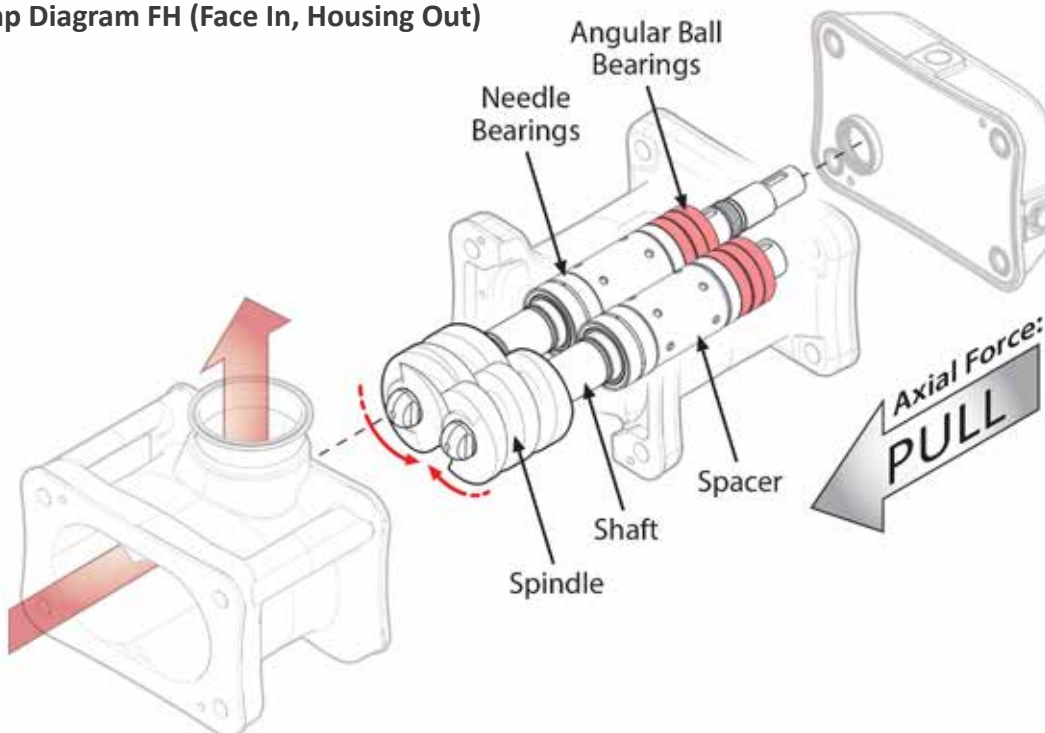



### Bearing Arrangement

The three bearings shown below (highlighted in red) are in tandem alignment when they share the Axial Force three ways. A single bearing is supporting the opposite direction.

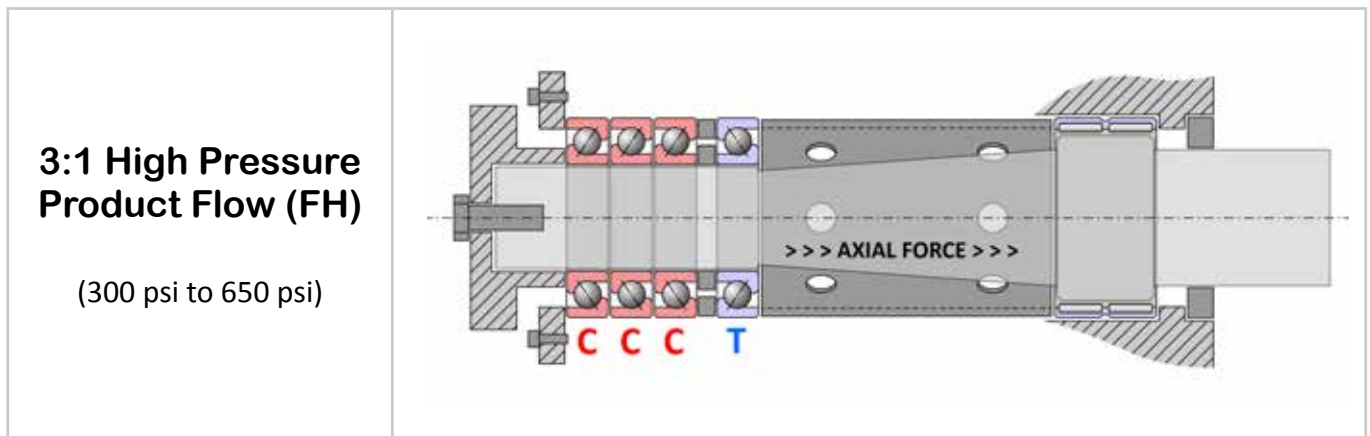
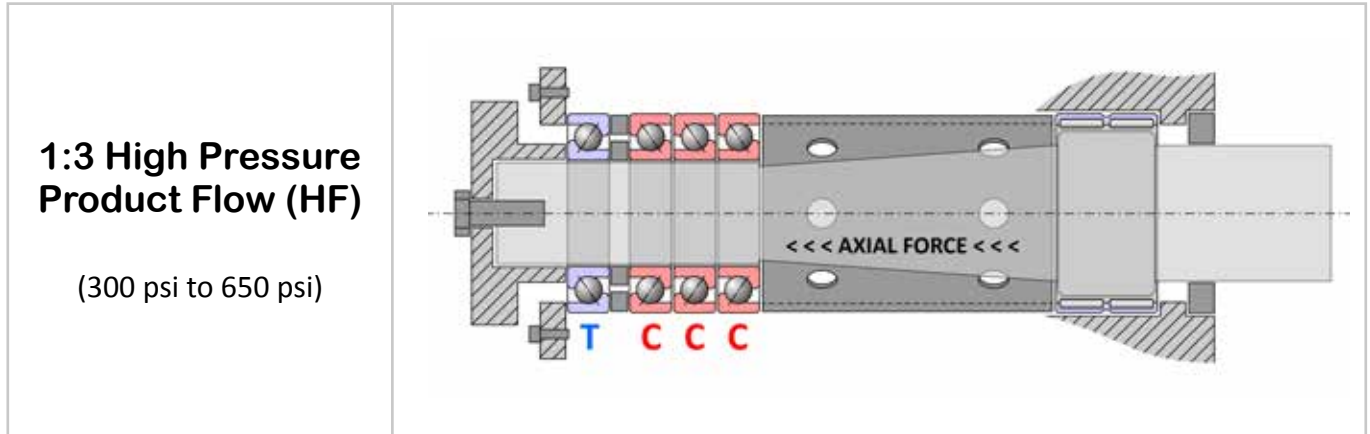

### Axial Load Calculation Method

Axial load is the force acting parallel to the axis of rotation along the shaft. The axial load can be found by using the following equation:

$$F_a = (P_o * A_o) - (P_i * A_i)$$

Where  $P_o$  is pressure out of the pump,  $P_i$  is the pressure into the pump.  $A_o$  is the area of the spindle facing the direction the product exists.  $A_i$  is the surface area of the part of the spindle facing where the product enters the pump.  $F_a$  is the axial load.

Area Out	Area In	Pressure Out	Pressure In	Force Out	Force In	Axial Force	Per Bearing
$A_o$	$A_i$	$P_o$	$P_i$	$A_o * P_o$	$A_i * P_i$	$(A_o * P_o) - (A_i * P_i)$	$F_a/n$
0.0060 m <sup>2</sup>	0.0079 m <sup>2</sup>	2500.00 kn/m <sup>2</sup>	1000.00 kn/m <sup>2</sup>	15.11 kn	7.85 kn	7.26 kn	3.63 k n

Table 2: An example of ViscoTwin 104 Front In /Top Out with two bearings in tandem.

**6.5 Equipment Commissioning Protocol**

Equipment Commission Protocol

Date Commissioned: \_\_\_\_\_ Job # \_\_\_\_\_

Serial #	Model #
----------	---------

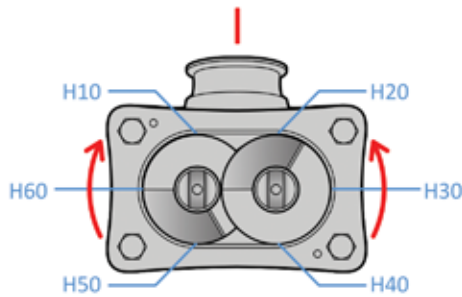

ROTATION DIRECTION

O (RIGHT)	I (LEFT)
-----------	----------

PICTURES TAKEN

YES	NO
-----	----

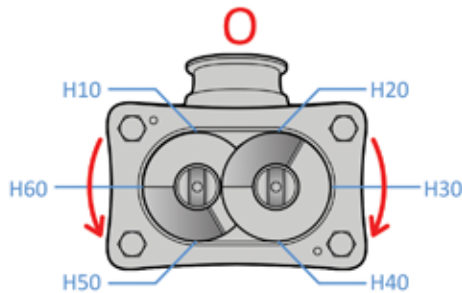

FRONT CLEARANCES

H10	mm
H20	mm
H30	mm
H40	mm
H50	mm
H60	mm

LABELS ATTACHED

YES	NO
-----	----

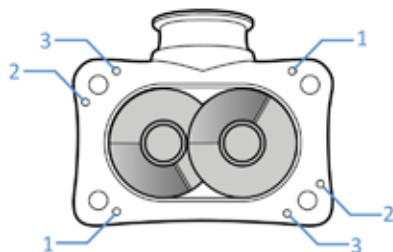

GEARBOX OIL

Kluber #
----------

SEAL MAKE & TYPE

ANGA	
HUHNSEAL	
Single Acting	
Double Acting	
SIC	
SIC/KE	
TC	
TC/KE	
FKM	
EPDM	
Perlast	
VT-70	

PIN ARRANGEMENT

Position #
------------

HARDENED SPINDLES

Yes	No
-----	----

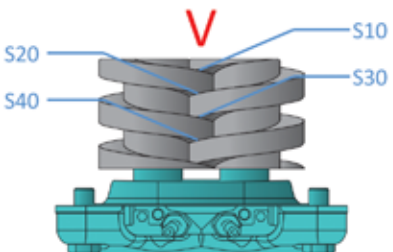

SPINDLE ARRANGEMENT

'V'	'A'
-----	-----

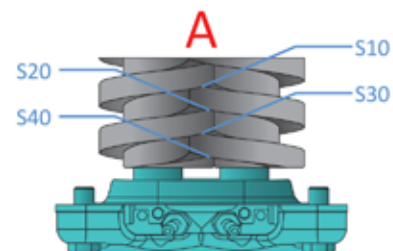

SPINDLE CLEARANCES

S10	mm
S20	mm
S30	mm
S40	mm
(1 inch = 1mm / 25.4)	
Comments:	

