

PROCESSTEC

GET TOMORROW'S TECHNOLOGY TODAY

Frame #4 "Service Rail"

Operation & Maintenance Manual

Published October 28th, 2020

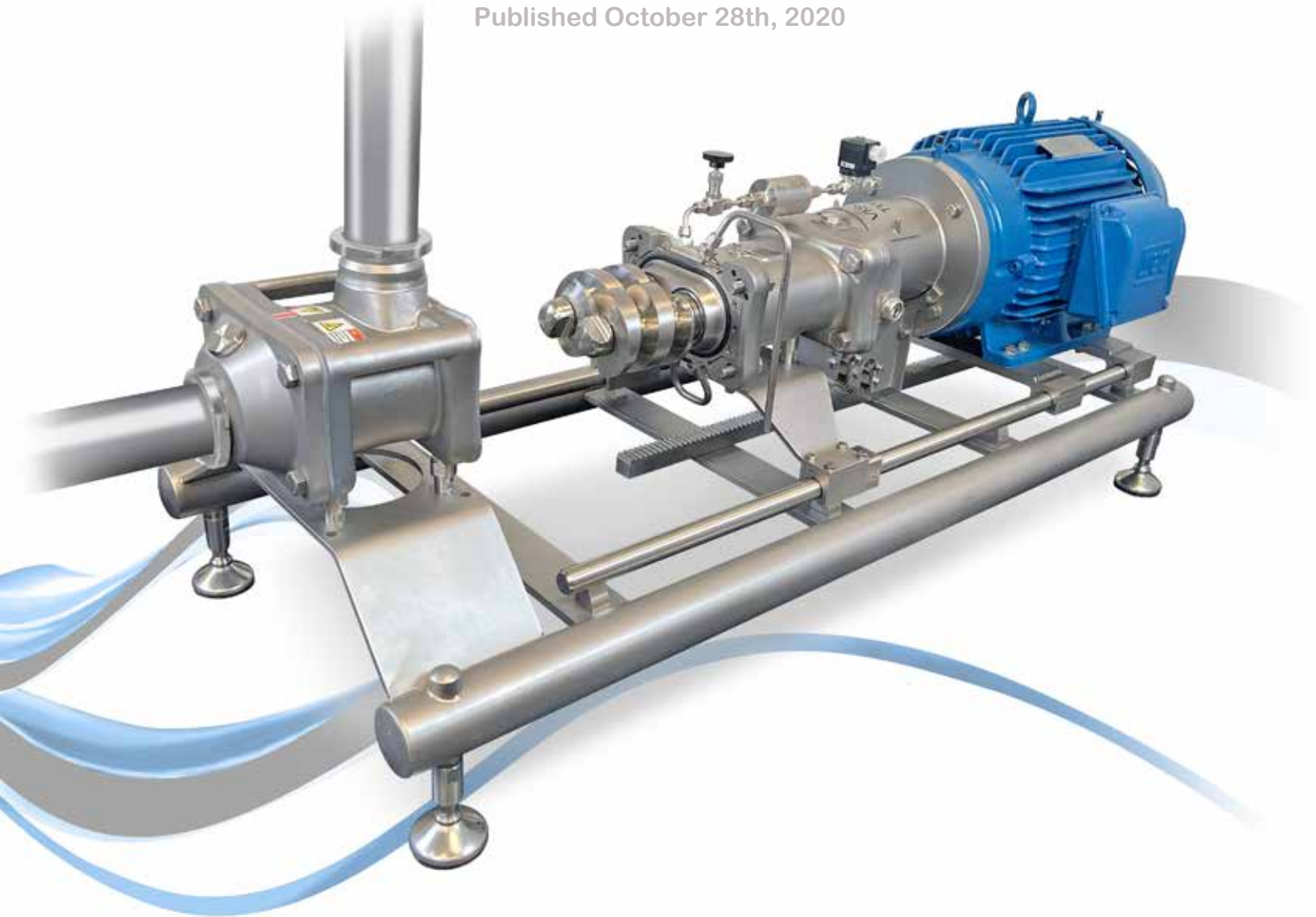

Address: 345 E. Tulare Avenue Unit E | Visalia, CA 93277 | Phone: +1 (559) 429-4227
Fax: +1 (559) 429-4228 | Email: info@processtec.com | <http://processtec.com>

1. ABOUT FRAME #4	1
1.1 Safety Notes	1
1.2 Working Principle	3
1.3 General Overview	4
1.4 Options	5
1.5 Explosion Drawing	6
2. INSTALLATION	7
2.1 Unpacking	7
2.2 Inspection / Technical Documentation	7
2.3 Hoisting and Transportation	8
2.4 Installation	9
2.5 Piping Before and After the Pump	10
2.5.1 Upstream Piping	10
2.5.2 Downstream Piping	11
2.5.3 Piping Before and After the Pump	11
3. OPERATION	13
3.1 Operating Frame #4	13
3.1.1 Opening Frame #4	14
3.1.2 Closing Frame #4	16
3.2 Alignment of Frame #4	18
3.2.1 Notes on Alignment Adjusters	18
3.2.2 Pump Housing Alignment	19
3.2.3 Additional Alignment Procedures	20
4. MAINTENANCE	21
4.1 Maintenance Preparation	21
4.2 Cleaning Frame #4	21
4.3 Notes About Longevity	21
5. TOOL-BOX	23
5.1 Spare Parts for Frame #4	23

This page intentionally left blank.

1. ABOUT FRAME #4

1.1 Safety Notes

This manual contains instructions which should be heeded to ensure personal safety and prevent damage to property. These instructions are highlighted by a warning triangle and a color to indicate the degree of the hazard. The following warnings should be observed when working around Frame #4, as well as when working around Twin Screw pumps in general:



ROTATING PARTS

Indicates rotating parts that can cause injury. Only perform work on or near these parts when it is locked to prevent rotation. It is advised to have a protective barrier surrounding the rotating part to prevent injury or property damage during operation.



CRUSHING PARTS

Indicates moving parts that can crush and cut. Perform work with awareness of how parts move and where these crushing parts can be encountered.



SUSPENDED LOAD

Indicates a suspended or overhung load, where parts can fall, slip, or tip over if not properly secured. Do no work on any part that is suspended and avoid being directly under or near a suspended load. Do not stand between a stationary object and a suspended load.



LIFTING OBJECTS

Indicates heavy objects that can cause muscle strain or back injury. Lifting aids and proper lifting techniques should be used to prevent injury.



HOT SURFACE

Indicates a surface is hot to the touch and can cause burn injury. Do not maintain or touch a hot surface until the pump is turned off and allowed to cool. If immediate repair is necessary, it is advised to wear protective gloves while handling a hot part.



CAUTION

When operating Frame #4, it is essential to wear appropriate protective equipment.

NOTE!

Commissioning and operating the **ViscoTwin** pump mounted on Frame #4 may only be performed by qualified personnel. Qualified personnel in terms of the safety instructions in this operating and safety manual are persons who have completely read this manual, as well as the **ViscoTwin** Operation & Maintenance Manual that accompanies this Frame and pump.

Furthermore, maintenance can only be performed by qualified maintenance technicians. Qualified maintenance technicians in terms of the maintenance instructions in this operating and safety manual are persons who have read Chapter 4 "Maintenance" of the **ViscoTwin** Operation & Maintenance Manual and have been trained by **Processtec** in the use and maintenance of the **ViscoTwin** pump. In lieu of in-person training by **Processtec** personnel, a qualified maintenance technician may also review the online maintenance movies available at <http://processtec.com>. **WARNING: ANY MAINTENANCE LEVEL 2 PERFORMED ON THE PUMP BY UNTRAINED PERSONNEL WITHOUT THE EXPRESS WRITTEN CONSENT OF PROCESSTEC WILL RELEASE PROCESSTEC OF ANY LIABILITY AND VOID ANY WARRANTY CLAIMS ON THE PUMP.**

In addition to this operating manual, general on-site regulations as well as city, state, and federal regulations applicable to accident prevention must be made available and followed.

The **ViscoTwin** may only be used in the applications as specified in Chapter 3 "Operation", in the **ViscoTwin** Operation & Maintenance Manual, and only in connection with the spare parts recommended by **Processtec, Inc.**

1.2 Working Principle

Frame #4 was designed to innovate the overall steps of installing, operating and maintaining **ViscoTwin** pumps. This Frame #4 was the culmination of many years of field experience, and was developed as a solution to problems that were not being addressed by others in the industry.

First, we wanted to engineer a solid frame structure to fully support the **ViscoTwin** pumps, and keep them secured in place. Second, we were looking for a way to streamline the periodic maintenance procedures, and also increase **WORKPLACE SAFETY** by moving away from the more dangerous operations of pump decoupling and motor hoisting, and any potential heavy lifting that if not done with care, could result in potential injuries or damages to property.

Previously, sanitary inspection for allergen free cleaning required detaching the pipes from the Pump Housing first, before removing the Pump Housing itself. These extra steps increased the amount of time it took to do pump maintenance, and to doublecheck that the sanitation process was done completely. With Frame #4, the upstream and downstream pipes remain attached to the Pump Housing, and the Spindles, Bearing Housing, and Motor can quickly and easily be detached from the Pump Housing, for in-place Sanitary Inspection.

An added bonus to this design is that the removal and re-installation of the Spindles can now be achieved with only one technician on site! Since Frame #4 facilitates the use of **Processtec's** Shaft Blocking Tool (a custom tool designed to lock the Drive Shaft in place), the Spindle Screw Bolts can be removed without the need of decoupling the motor, thus eliminating the need for a 2nd technician to hold a locking bar in place on the coupler.

In addition to these features, **ViscoTwin** pumps that are shipped with Frame #4 include **Processtec's** latest innovation, the **Gear Housing Inspection Port**. This access port is machined into the back of the Gear Housing and allows for gapping and timing of the **ViscoTwin** pumps without the need to remove the Gear Housing, or even drain the Gear Oil - this is a huge time saver!

Finally, since Frame #4 is easily accessible from either side, it allows for pump inspection or maintenance from all possible angles without having to transport the pump to another location.

1.3 General Overview

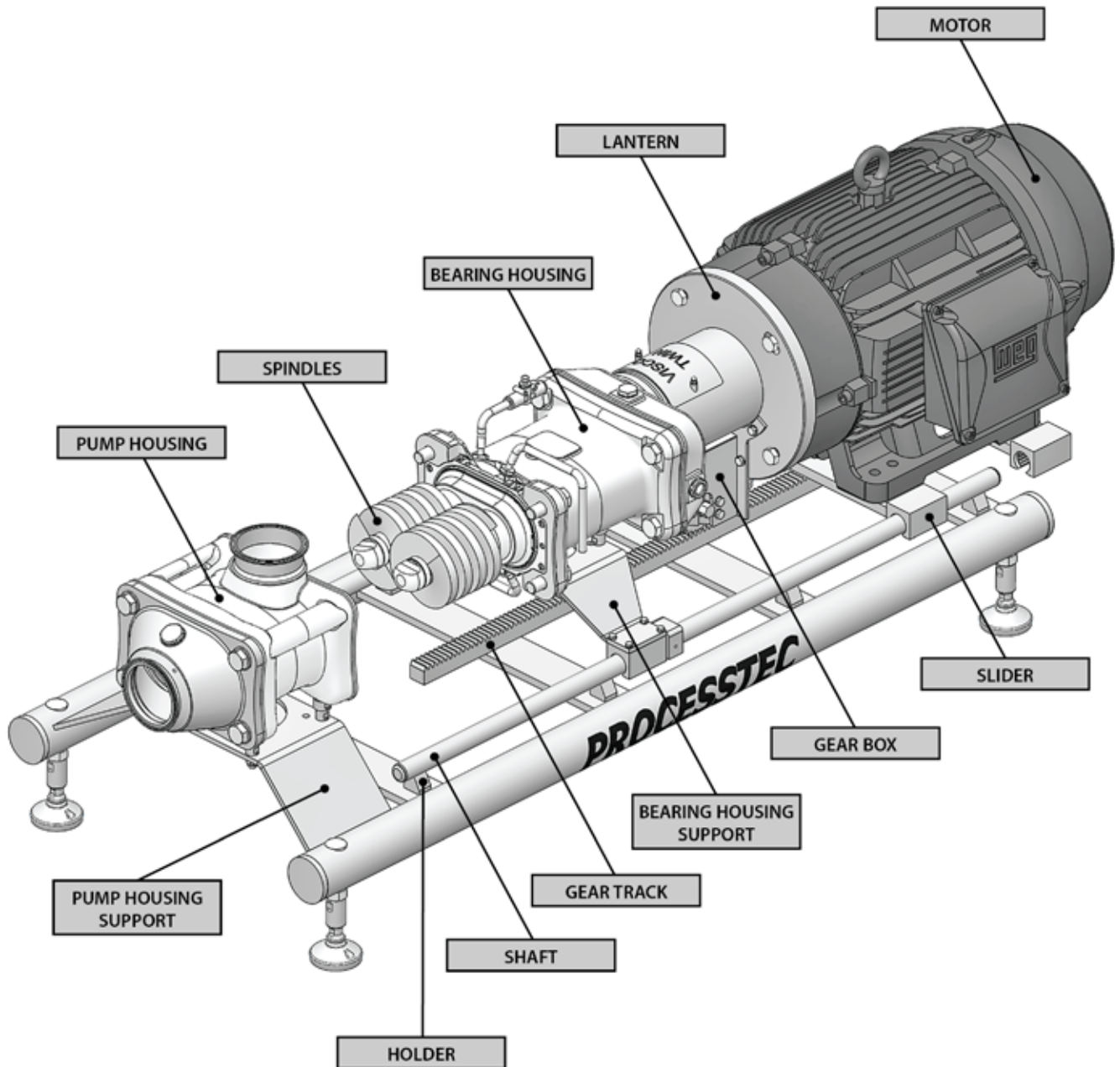

1.4 Options

Processtec's Frame #4 is shipped with these options as standard:



Processtec's Frame #4 is also available with these additional custom options:

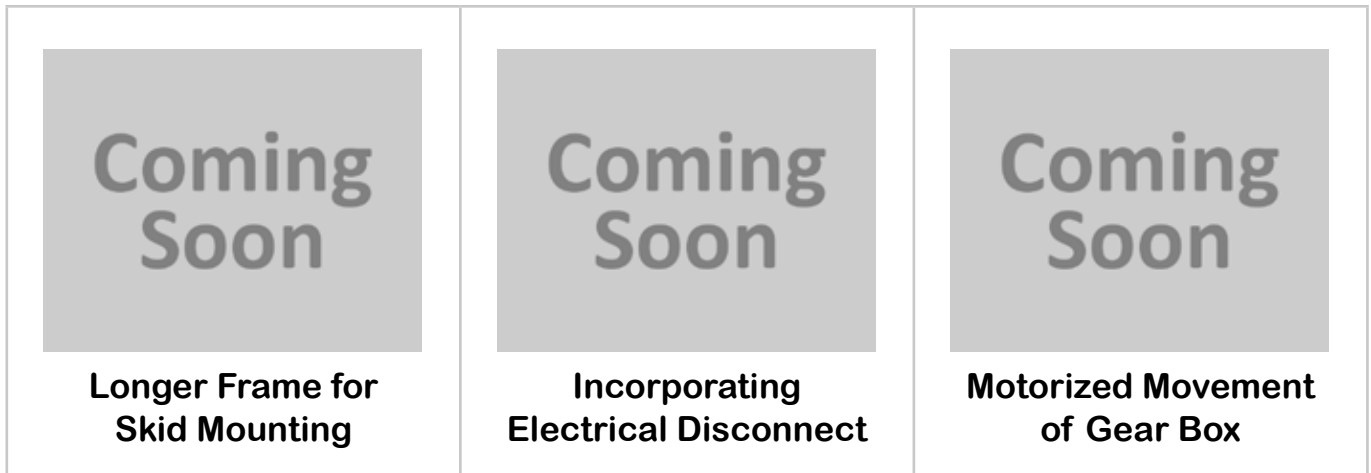

1.5 Explosion Drawing

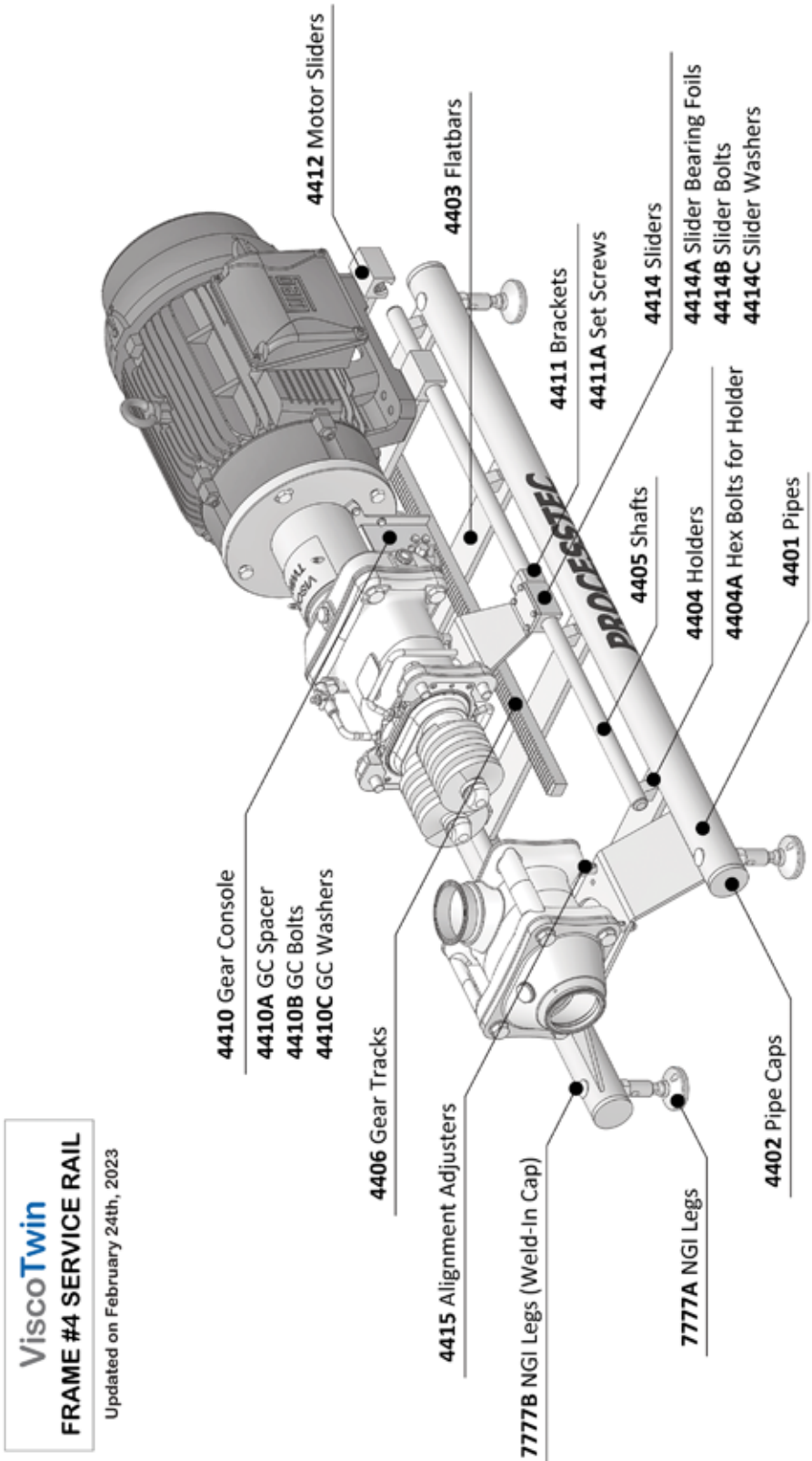

2. INSTALLATION

2.1 Unpacking

Check the contents and all wrapping when unpacking the pump. Inspect the entire shipment carefully for any damage that may have occurred during shipping. Immediately report any damage to the carrier. Keep the protective caps over the pump inlet and outlet in place until the pump is installed.

If possible, save the wooden pallets that Frame #4 arrived on for potential future use, in case the Frame and pump needs to be shipped back to **Processtec** for special services.

2.2 Inspection / Technical Documentation

Inspect the pump for visible shipping damages on pump head, lantern with coupling, motor, and frame. Locate the technical documentation that is shipped with the pump including:

0. Pump Shipping Documents
1. **ViscoTwin** Configuration Key
2. Commissioning Protocol
3. Pictures
 - 3.1 Pin Installation (1/2/3)
 - 3.2 Spindle Arrangement (V/A)
 - 3.3 Pump Housing (FH/HF)
4. Spindle and Pin Configuration
5. User Manuals
 - 5.1 Frame #4 Manual
 - 5.2 **ViscoTwin** Manual
6. Spare Parts Catalog
7. Recommended Tools Catalog

Use these documents to ensure the pump is shipped as ordered, and store these documents safely for future reference. All **ViscoTwin** pumps are labeled with an engraved metal plate that contains the pump model, serial number and Component ID which identifies the building plan of the pump at **Processtec**.

2.3 Hoisting and Transportation

Frame #4 along with the **ViscoTwin** pump that is mounted to it, were designed to be transported as one entire unit, without needing to move the Pump and the Frame independently from each other, except where warranted by the circumstances.

LIFTING FRAME #4 WITH A PALETTE JACK OR FORKLIFT FORKS

Forklift forks should be used to lift the Frame #4 with the **ViscoTwin** Assembly. Slide the forks underneath the 3" Round Bars, taking care to keep the forks underneath the Frame for total support.

A Palette Jack can also be used to lift Frame #4 if it is located on a relatively flat surface.

IMPORTANT NOTE:

Lifting Frame #4 should only be done when the **ViscoTwin** Pump is fully closed, with the Spindles in the Pump Housing, and the Pump Housing Bolts fully torqued. **Moving the pump in an open state may cause the need for major re-alignment of the entire Motor and Pump Assembly.**

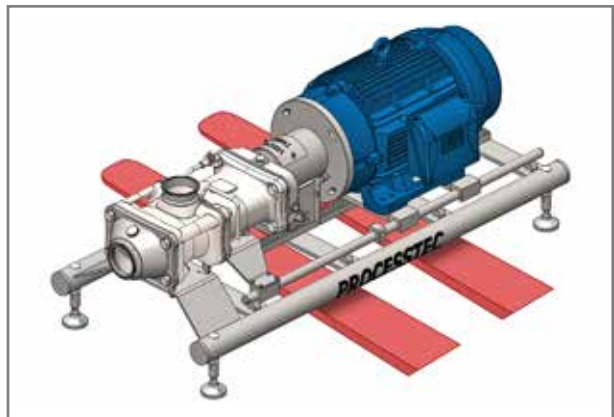

STRAP PLACEMENT FOR HOISTING THE MOTOR WITH A FORKLIFT LIFTING HOIST

Forklift forks with a Forklift Lifting Hoist can also be used for lifting the **ViscoTwin** Motor off of the Frame once detached, in conjunction with a hoisting strap. Make sure that the **ViscoTwin** Motor is completely supported and that the Forklift Lifting Hoist is firmly secured to both forks before lifting.



2.4 Installation

The following points need to be considered while installing the pump in the system:

1. Frame #4 is delivered with height adjustable feet to accommodate sloped floors for drainage. The entire Frame and Pump system should be level so the pump operates even with a low oil level, ensuring the oil is still able to reach all of the bearings. To level the Frame, adjust the height-adjustable feet on the Frame individually (see red arrows), until the entire Frame is level.

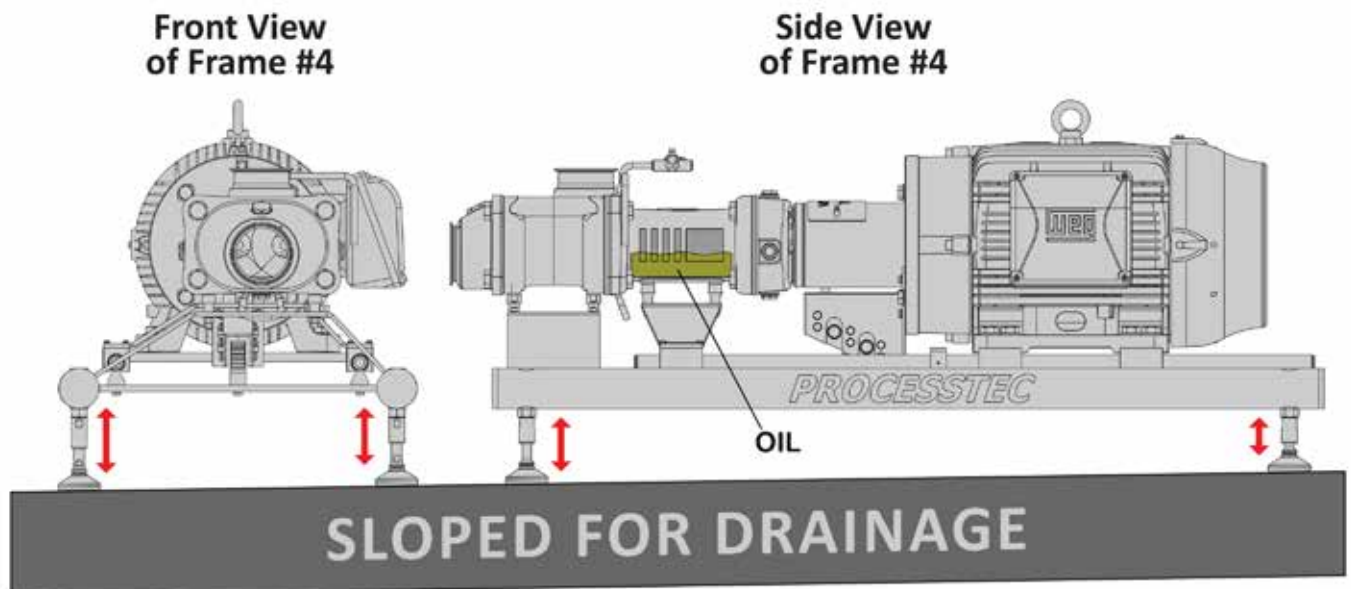

2. No excess forces should be exerted on the pump from piping systems, platforms etc.
3. Ensure good access to both sides of the Frame, so that the pump can be opened and closed via the Gear Box from either side of the Frame.
4. Ensure good access to the oil sight glass at the gear housing for regular inspection from operators and maintenance personnel.
5. Ensure good access to the bolts (Pos. 1016) to easily remove the Pump Housing with a extended torque wrench for sanitary inspection.
6. Ensure that the whole Frame can be easily accessed from at least one side, to allow for maximum ease during pump maintenance, sanitary inspection, and oil changes.
7. Connect the Seal Water if the pump is equipped with a double seal that requires seal water. It is recommended that the seal water automatically starts and stops with the pump to save water.
8. Ensure that the electric wiring can easily be disconnected for maintenance and is not a safety hazard or dirt trap. Also ensure that no wiring is capable of being pinched or crushed as the motor assembly is moved along the sliders, and the gears are moving along the rack.

2.5 Piping Before and After the Pump

Sizing the correct upstream and downstream piping including valves and fittings is very involved and depends on the experience of the application engineer. **Processtec** developed a sizing program that accounts for kV values of common sanitary valves and pipe fittings at various sizes and port arrangements. The program requires the input of a valid apparent viscosity value. Please consult **Processtec** engineering if you need support to verify your piping arrangement.



2.5.1 Upstream Piping

The upstream piping of the pump requires the utmost attention. The NPSH available from the system (NPSHa) needs to be higher (higher absolute pressure) than the NPSH required (NPSHr) by the pump (lower absolute pressure).

The NPSHa must be less than the NPSHr or cavitation occurs. The pumped media creates vaporized bubble that immediately collapse & damage both the product & the pump.

The **ViscoTwin** has excellent suction capabilities and will maintain it throughout its life cycle if operated per design. Since **ViscoTwin** pumps can be used with very viscous media, any flow restrictions preventing the product from arriving at the pump suction nozzle at the desired flowrate must be removed. If the pump is sped up faster than the product can enter the pump, the pump cavitates, and will damage the pumped media, and the pump itself.

Typical installation errors that create cavitation:

- Product has a higher apparent viscosity than anticipated. Typically, colder product results in a higher apparent viscosity.
- The upstream pipe is undersized in diameter as well as the associated valves, fittings, elbows, and tees.
- Too many restricting devices in the suction line like valves, tees, elbows, or other pipe restrictions.
- The suction pipe is too long.
- Particulates in the product are caught in valves, restricting the flow

2.5.2 Downstream Piping

The max discharge pressure on standard **ViscoTwin** models depends on the pump configuration and the pumped media. Pump configurations with the largest possible spindle pitch max out between 12 bar and 14 bar. Pumps equipped with the smaller spindle pitches (consult the options table) have a max discharge pressure of 25 bar (362 psi). The max temperature with standard elastomers is 130° C (266° F).

If the desired discharge pressure can not be met with the **ViscoTwin 104 NG** due to spindle pitch restriction, **Processtec** recommends using the **ViscoTwin 130 NG** with a smaller spindle pitch.

For higher discharge pressures and temperatures, please consult **Processtec** Engineering to customize a durable pump setup for pressures up to 45 bar (692 psi) and 200° C (390° F). Our customized pumps are engineered for the longevity of the bearings, elastomers, mechanical seals, and spindles. We can calculate the expected bearing life with optimized configurations for temperatures up to 180° C.

2.5.3 Piping Before and After the Pump

The **ViscoTwin** pump operates like a hybrid pump between a centrifugal pump and an absolute positive displacement pump, primarily due to slip between the left and right hand spindles and between the spindles and the pump housing. Due to this fact bypasses are generally not needed, allowing for a deadzone-free piping arrangement. **ViscoTwin** pumps can be installed in series without a bypass if proper engineering principles are applied.

In case the pump is cleaned with an external CIP supply pump for a higher flowrate than the **ViscoTwin** is designed for, the pushing CIP solution will propel the **ViscoTwin** pump at a relatively low flow restriction, making a bypass obsolete. The pump will start to spin, even if it is not started. No damage will occur if correct engineering principles are applied.

This page intentionally left blank.

3. OPERATION

3.1 Operating Frame #4



Frame #4 is OPENED and CLOSED by using a 19mm socket wrench (with extender) on the small gear drive wheel of the Gear Box, from either side of the pump. While the larger gear wheel can also be turned to move the assembled Pump and Motor on the sliders, it is recommended to use the Small Gear Wheel for more precise control.

3.1.1 Opening Frame #4

The ACTION STEPS for OPENING Frame #4 are as follows:

STEP 1) FOLLOW LOTO PROCEDURE

Follow LOTO (Lock Out, Tag Out) procedure before beginning any work on the pump.



STEP 2) REMOVE THE PUMP HOUSING BOLTS

Loosen and then remove the Pump Housing Bolts (Pos. 1016).



STEP 3)

TURN THE SMALL GEAR WHEEL

Use a 19mm socket wrench with extender on the Small Gear Wheel of the Gear Box, and from either side of Frame #4, turn the Small Gear Wheel to slide the Spindles, Bearing Housing, Lantern and Motor away from the Pump Housing.



STEP 4)

NOW YOU HAVE ACCESS

Now you have access to the Spindles, Mechanical Seals and Seal Housing for further cleaning and inspection as necessary.



3.1.2 Closing Frame #4

The ACTION STEPS for CLOSING Frame #4 are as follows:

STEP 1)

TURN THE SMALL GEAR WHEEL

Use a 19mm socket wrench with extender on the Small Gear Wheel of the Gear Box, and from either side, turn the Small Gear Wheel to slide the Spindles, Bearing Housing, Lantern and Motor towards the Pump Housing.

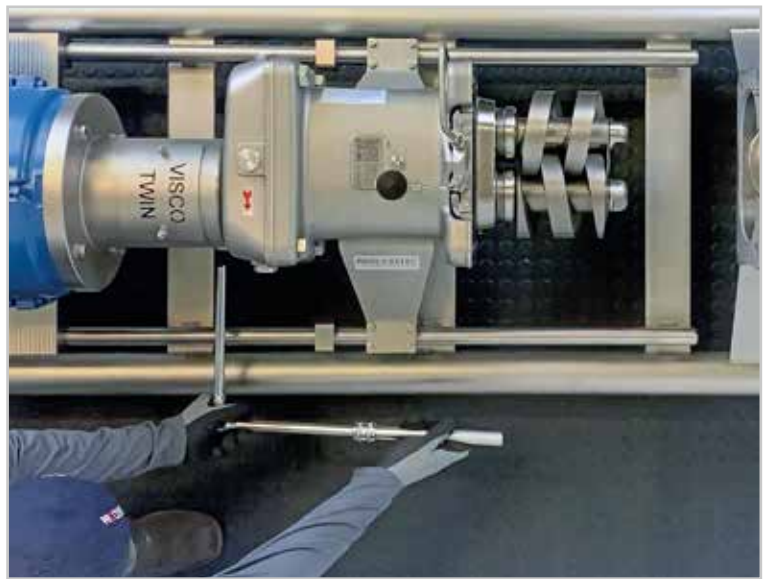

STEP 2)

CHECK SEAL HOUSING O-RING

Make certain that the Seal Housing O-ring (Pos. 1088) is properly seated, and does not pinch during the closing of Frame #4.

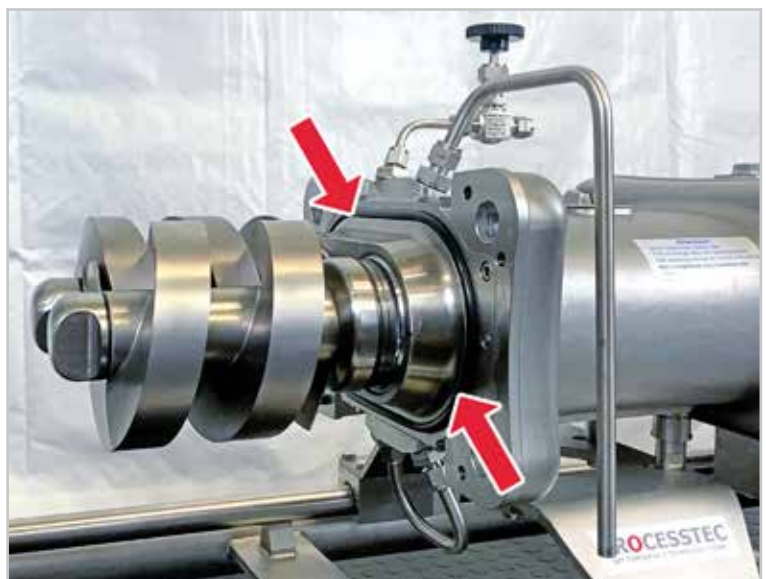

STEP 3)

CLOSE FRAME #4

Continue turning the Small Gear Wheel until the Spindles are completely inside the Pump Housing. The entry of the Spindles into the Pump Housing should be smooth and uninterrupted.



STEP 4)

REINSTALL PUMP HOUSING BOLTS

Reinstall the FOUR (4) Pump Housing Bolts (Pos. 1016) and hand tighten. Then, moving in a star pattern, torque each bolt to 150 Nm (110.6 ft-lb).



3.2 Alignment of Frame #4

Frame #4 is shipped from **Processtec**, fully aligned and ready for operation. During normal operation, the pump should stay completely aligned, and re-alignment should only be performed when necessary, such as when the Pump Housing has been removed or replaced.

3.2.1 Notes on Alignment Adjusters

There are FOUR (4) Alignment Adjusters that support the Pump Housing on the frame, and each one can be individually adjusted to control the horizontal position and vertical height of the Pump Housing. Adjusting the two nuts on one side of the Pump Housing will rotate the housing along the center axis of the frame, while adjusting all four nuts in the same direction would either raise or lower the height of the housing, depending on how the Alignment Adjuster bolts are set.

The FOUR (4) Alignment Adjusters that support the Bearing Housing, can be slightly adjusted as necessary, although most of the alignment should be done by re-aligning the Pump Housing to accommodate the spindles (Please refer to Subsection 3.2.2 "Pump Housing Alignment" on the following page). This is ideally done before any process connections or piping is installed.

To adjust an individual Alignment Adjuster:

1. Loosen the **Bottom Nut** of the Alignment Adjuster bolt, and back it off a couple of threads.
2. Now, while using an open-ended wrench to secure the **Middle Locking Nut**, use a crescent wrench on the **Top Height Adjusting Nut**, and turn clockwise to lower the nut, or counter-clockwise to raise the nut.
3. Once the ideal height is achieved, grip the **Top Height Adjusting Nut** with a crescent wrench to secure it in place, and use an open-ended wrench to snug tighten the **Middle Locking Nut** down, against the top surface of the support bracket.
4. Adjust the THREE (3) adjacent Alignment Adjusters in the same fashion, and once the desired positioning has been achieved, tighten the **Bottom Nuts** on the Alignment Adjuster Bolts up against the bottom surface of the support bracket.



NOTE: The **Middle Locking Nut** is designed to be extra tall in order to cover the exposed threads of the bolt between the **Top Height Adjusting Nut** and **Middle Locking Nut**.

3.2.2 Pump Housing Alignment



The proper order of procedure for Alignment of the Pump Housing on Frame #4 is as follows:

1. With the Motor, Lantern, and Bearing Housing all aligned and secured together, you must loosen, but not totally remove the Alignment Adjuster bolts that secure the Pump Housing to the Pump Housing Support Bracket.
2. While one person lifts the Pump Housing slightly, a second technician should operate the Small Gear Wheel on the Gear Box to move the spindles into the Pump Housing. The Pump Housing being loosely attached at this point is key to allowing it to change position in order to fit onto the spindles as they enter the housing.
3. Once completely closed, the Alignment Pins between the Pump Housing and Bearing Housing (if still in their proper location) will align the Spindles into the Pump Housing based on the pump's Pin Configuration, with the proper clearances able to be confirmed with a feeler gauge (this would require the removal of the Pump Face).
4. Tighten the Hex head bolts (Pos. 1016) that secure the Bearing Housing to the Pump Housing. Torque to 150 Nm, moving in a star pattern.

3.2.3 Additional Alignment Procedures

Typically, the alignment steps covered in Subection 3.2.2 "Pump Housing Alignment" on page 17 should be followed to re-align the Pump Housing to the Spindles. However, the steps outlined below should only be undertaken in extreme circumstances, such as if Frame #4 was dropped during transport or if other major damage has occured.

If you have any questions, you may call **Processtec** for further assistance.

Motor Mount Bolts (Side to Side Alignment)

The bolts that mount to the motor mount sliders can be loosened slightly, to allow the motor with attached lantern and bearing housing to be shifted slightly from side to side. Once a position has been set, tighten the bolts to lock the motor position in place on the motor sliders.

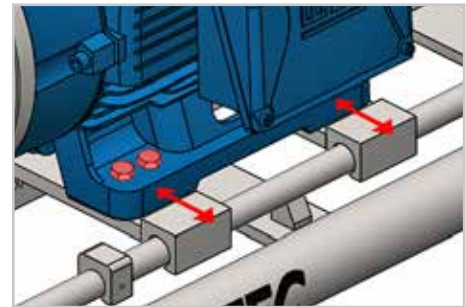

Lantern Flange Bolts (Rotational Alignment)

The Lantern flange that is secured to the motor has FOUR (4) bolts that can also be loosened when slight adjustments are needed in rotation along the center axis of the pump. You would also need to loosen the Alignment Adjusters that support the Bearing Housing, to allow for slight changes in rotation. Once the correct rotational alignment has been achieved, you would then re-tighten the Alignment Adjusters that support the Bearing Housing.

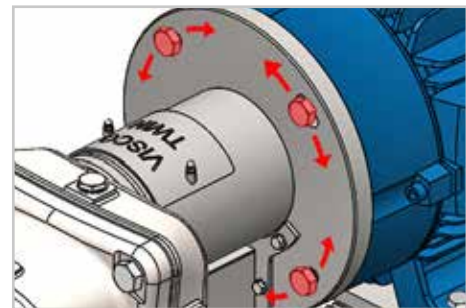

Bearing Housing Alignment Adjusters (Overall Level)

Minor adjustments to the overall level of the pump in relation to the Frame can be made by adusting the height of the Alignment Adjusters that support the Bearing Housing. Minimal adjustments here allow for the ballpark alignment of the spindles to the Pump Housing, with the final alignment taking place by repositioning the Pump Housing (See Subsection 3.2.2 "Pump Housing Alignment" on page 17).

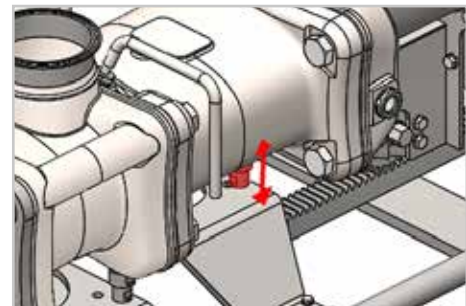

4. MAINTENANCE

4.1 Maintenance Preparation

Before doing Maintenance on the **ViscoTwin** attached to Frame #4, please observe the following precautions:

- Follow LOTO (Lock Out, Tag Out) Procedure.
- Practice workplace safety AT ALL TIMES.
- Observe the immediate area for potential spills and leakages that may create slip hazards, or electrical hazards.
- Read through the entire steps of the Maintenance Procedure to ensure a full understanding before beginning on step 1.
- Have the proper tools neatly arranged for quick and easy access.

4.2 Cleaning Frame #4

Frame #4 itself can be cleaned and sanitized by using standard cleaning chemicals for the surface cleaning of Stainless Steel. Complete attention to detail is recommended for maintaining overall pump hygiene.

Standard CIP procedures can be carried out on the **ViscoTwin** Pump when attached to Frame #4. Consult the Operational Manual for **ViscoTwin** Pumps for detailed cleaning procedures.

4.3 Notes About Longevity

Following specified operating procedures will ensure that your **ViscoTwin** Pump has a maximum lifespan. Improperly trained technicians, unsafe shortcuts, and other improper uses of the pump may contribute to an overall shorter lifespan. Take proper care of the pump to maximize its operational longevity.

This page intentionally left blank.





5. TOOL-BOX

5.1 Spare Parts for Frame #4

Below are all of the Spare Parts available from **Processtec** for use on Frame #4.

C-ID #	REQUIRED PER FRAME	DESCRIPTION	IMAGE
22222	2	SLIDER	
22244	8	SLIDER BEARING FOIL	
22242	8	SLIDER HEX HEAD SCREW (M6 x 20)	
22243	2	SLIDER WASHERS	
22223	8	ALIGNMENT ADJUSTER	
22221	1	BEARING HOUSING SUPPORT	
22220	2	SLIDER 130-N320	

C-ID #	REQUIRED PER FRAME	DESCRIPTION	IMAGE
22218	2	SLIDER 104-N280	
22219	2	SLIDER 130-N280	
22217	2	BRACKET w/2 SET SCREWS	
22212	1	GEAR BOX	
22214	1	SPACER FOR GEAR BOX	
18554	5	HEX HEAD BOLT (M8 x 25)	
18377	5	WASHER	
22213	2	3" PIPE	
22215	4	3" CAP	

C-ID #	REQUIRED PER FRAME	DESCRIPTION	IMAGE
22211	1	PUMP HOUSING SUPPORT	
22216	4	3" x 1/2" FLATBAR	
22208	8	HOLDER	
22224	8	HOLDER BOLT ISO 4017 (M10 x 55) (1.5mm Pitch)	
22209	2	SHAFT	
22210	1	GEAR TRACK	
21557	4	NGI LEG	
21558	4	NGI CAP	

This page intentionally left blank.