

PROCESSTEC
GET TOMORROW'S TECHNOLOGY TODAY

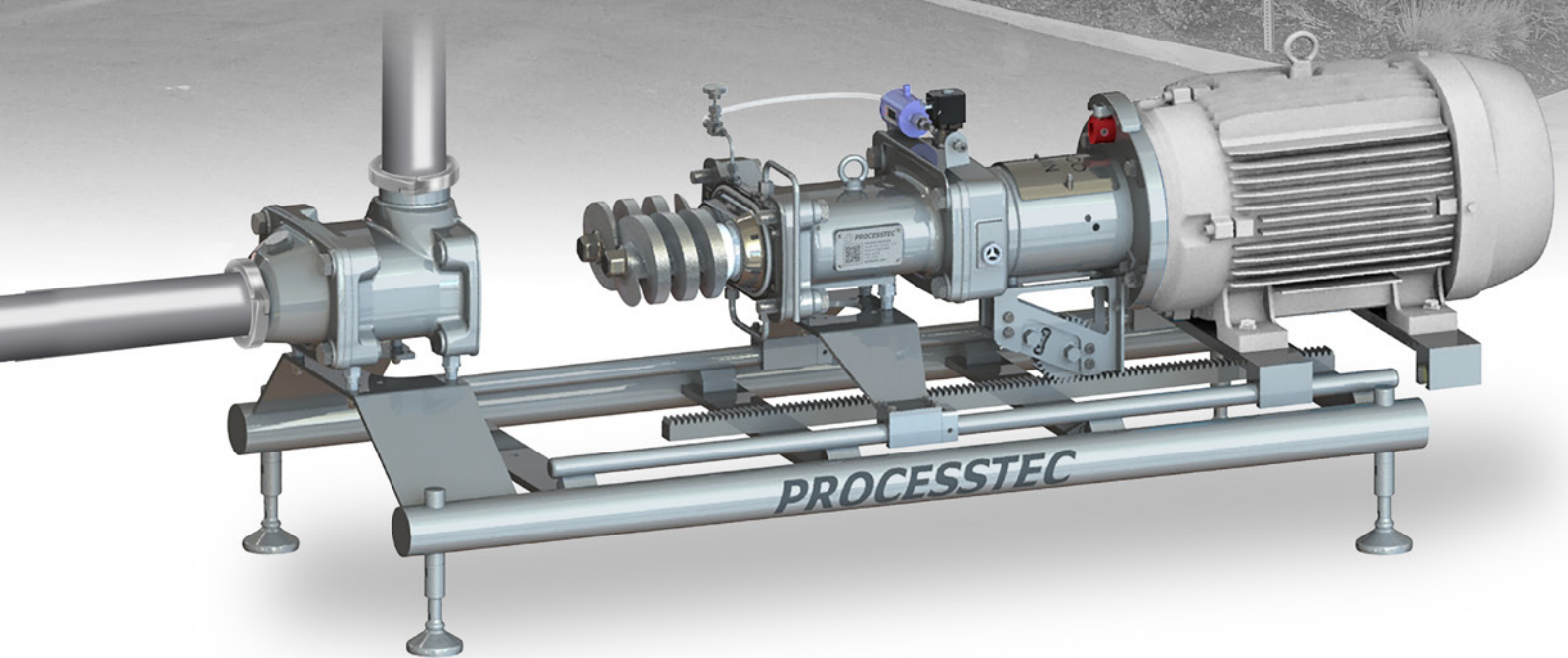

ViscoTwin G10

pumps everything • better

Features of Twin Screw Pumps

Twin Screw Pumps are versatile, capable of handling a wide range of media—from air and vapor to water and highly viscous products like silicone. Their working principle supports hygienic design, making them ideal for sanitary applications. As volumetric pumps, they operate as Positive Displacement (PD) pumps, ensuring consistent and efficient performance.

Twin Screw Pumps offer efficiency comparable to standard centrifugal pumps when handling water. However, as media viscosity increases, centrifugal pumps lose efficiency, while Twin Screw Pumps excel. Reduced slip and lower RPMs allow Twin Screw Pumps to maintain superior performance with thicker fluids.

When a PD pump is required, Twin Screw Pumps offer simplicity in both installation and operation. They handle a wide range of applications with ease, including CIP solutions, thin and thick media, sensitive products with chunks, air/water mixtures, slurries, high-viscosity concentrates (up to 650 psi), and sterile processes under the highest hygienic standards.

Comparison of typical system setup

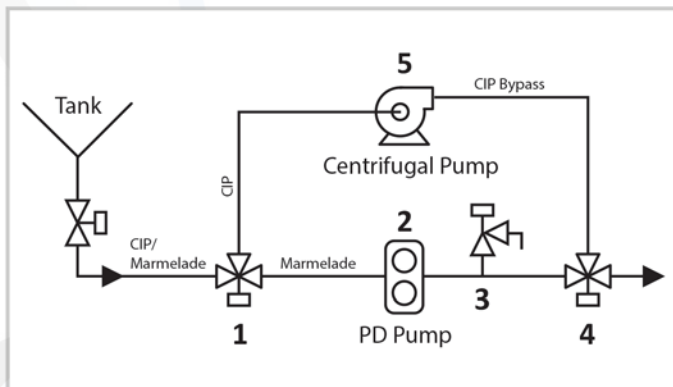

**with PD Pump
(5 devices)**

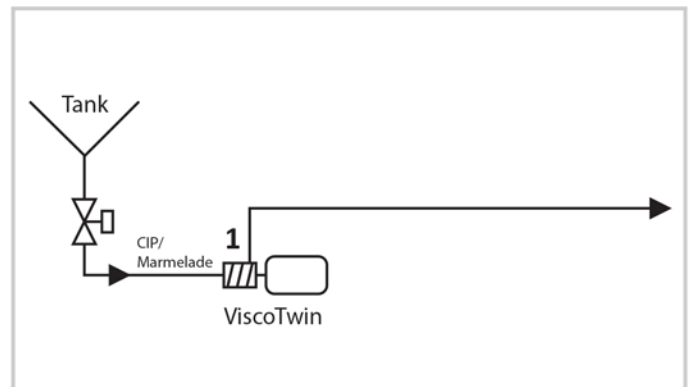

**with ViscoTwin
(1 device)**

The ViscoTwin G10

- The pump housing is designed to gently move sensitive particulates like macaroni in cheese sauce, chunks in soups or cheese curd in whey.
- Viscosities ranging from water in air (0.3cps) to Silicone (1 Mio cps).
- Very high suction capability (low NPSHr) at 46 mbar(a).
- Max discharge Pressure with E-Spindles at 45 bar (650psi).
- Max operating temperature at 380°F with FFKM Elastomers.
- High suction capability as mixed phase pump with 70% air in 30% liquid.
- Fully bi-directional operation due to 4 bearings per shaft, 2 bearings for pull and 2 bearings for push.
- Customizable as sterile pump with steam/condensate barrier.
- Many seal, pump face, frame and coupling options available.
- Safety First! The ViscoTwin is built with your operators and technicians in mind.



| Properties | ViscoTwin 70 | ViscoTwin 104 | ViscoTwin 130 |
|----------------------------|-------------------|-------------------|------------------|
| Standard Pressure max | 25 bar (360 psi) | 25 bar (360 psi) | 25 bar (360 psi) |
| High Pressure max max | 45 bar (650 psi) | 45 bar (650 psi) | 45 bar (650 psi) |
| Shaft RPM max | 5000 rpm | 5000 rpm | 5000 rpm |
| Standard Temp max | 130°C (266°F) | 130°C (266°F) | 130°C (266°F) |
| High Temp max | 180°C (356°F) | 180°C (356°F) | 180C (356°F) |
| Viscosity | 0.1 to 1 Mio mPas | 0.1 to 1 Mio mPas | 0.1 to Mio mPas |
| Particulate Size S-Spindle | 21mm | 26mm | 32mm |
| Pump Face max | DN80 / OD3" | DN100 / OD4" | DN150 / OD6" |
| Pump Face std | DN80 / OD3" | DN80 / OD3" | DN100 / OD4" |
| Pump Housing | DN65 / OD2.5" | DN80 / OD3" | DN100 / OD4" |

Why ViscoTwin?

- **FAST ACCESS FOR INSPECTION**

Just remove the FOUR (4) bolts to gain access to the Mechanical Seals, for inspection or cleaning.

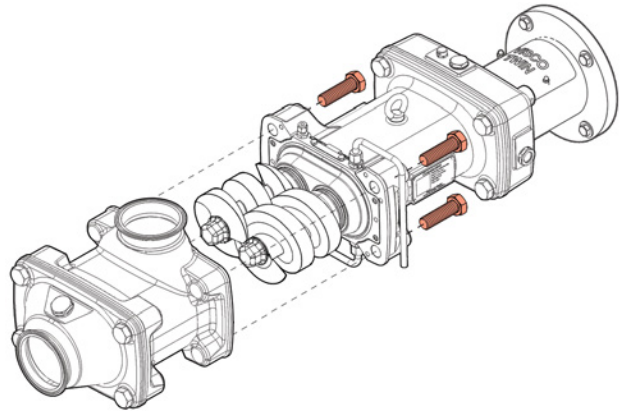

- **GENTLE PRODUCT FLOW**

The ViscoTwin G10 is designed to handle sensitive products without tearing or destroying large particulates. From berries to noodles, the ViscoTwin G10 pumps it with care!



- **MANY WAYS TO CONFIGURE**

ViscoTwin G10's are highly configurable to optimize various application requirements and installation setups.



- **EASY TO OPERATE & MAINTAIN**

Once installed, all parts used to build the ViscoTwin G10 are designed for max durability, reliability, performance and are easy to maintain.

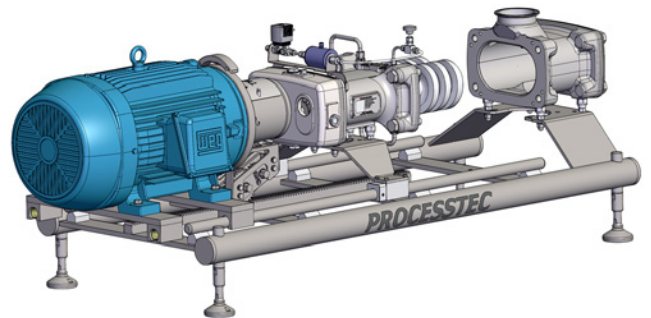

- **COMPLETE ONLINE SUPPORT**

Get immediate access to support documentation that is available online: Manuals, Explosion Drawings, Torque Charts, Spare Parts Catalogs, How-to Movies, Online Sizing Software and Configuration Charts. All of these are available online at processtec.com



ViscoTwin G10 Pump Face Options



The **STANDARD PUMP FACE** is optimized to gently move the product from the inlet pipe to the conveying area of the spindles. All tearing edges are removed, which greatly improves the suction properties of the pump (NPSHr). Each pump face is equipped with an Aseptoflex port to flush-mount an IFM vacuum gauge.



The **DUAL INLET PUMP FACE** is designed to conjoin two product streams at the pump head.

The design of the product flow prevents "bridge" building in the suction pipes.



The **WELD-IN FLANGE** is used for close-coupled installation of the pump to a tank or auger in case the product is too viscous to flow through a valve and pipe into the pump.

ViscoTwin G10 Frame Options (1-6)

The **ViscoTwin G10** pump is available by itself, or mounted to a custom developed Frame to meet your needs. Whether you need to fit into tight spaces (Frame 6) or gain total mobility (Frame 5), **PROCESSTEC** offers a solution.

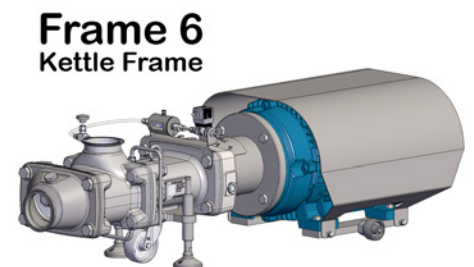
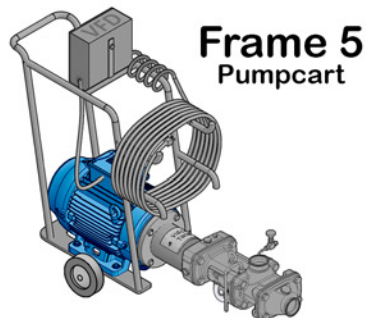
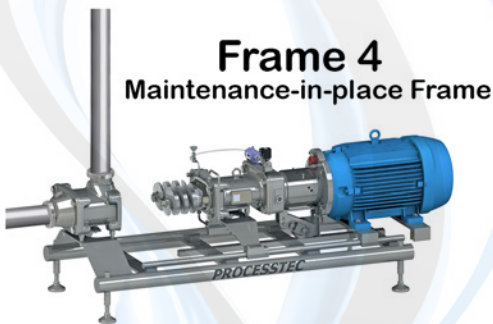
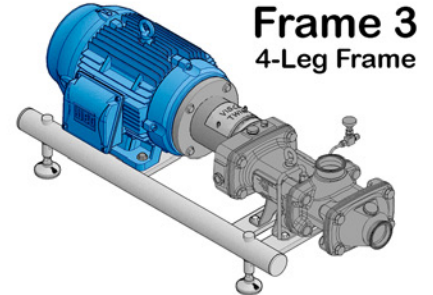
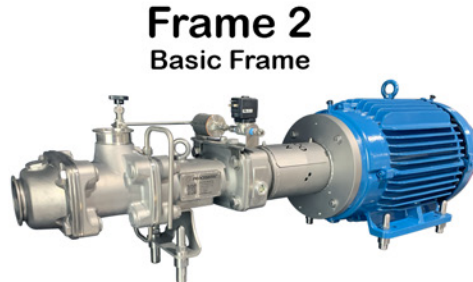
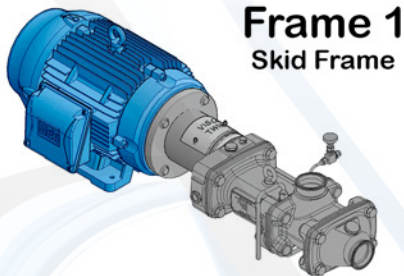

ViscoTwin G10 Coupling Options



Standard Coupler

Each pump coupler includes a custom bore to insert a Shaft Blocking Tool for safe spindle bolt loosening & tightening.



Disengaging Coupler

This option automatically disengages the Motor Shaft from the Pump Drive Shaft in the event of a blockage in the Spindle Area, preventing catastrophic damage to the pump. The pump coupler also hosts the bore for the Shaft Blocking Tool.

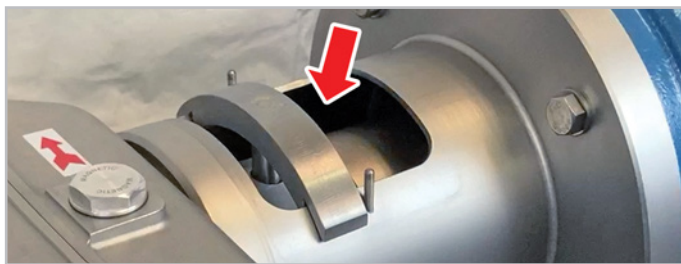

ViscoTwin G10 High Pressure Options

In case pressures above 360 psi are required, *PROCESSTEC* offers customized system upgrades for 650 psi and 375° F operation. This is limited to selected spindle pitches, therefore limiting max flowrate and min product viscosity.

High Pressure Flow Rates at 650 psi (with Oil Cooler)

| Model | Flow Rate | Speed | Pressure | Viscosity | Torque | Motor |
|----------|-----------|-----------|----------|-----------|-----------|--------|
| VT70.22 | 57 GPM | 3,400 rpm | 650 psi | 1,000 cps | 61 lb-ft | 40 hp |
| VT104.27 | 112 GPM | 3,400 rpm | 650 psi | 1,000 cps | 137 lb-ft | 100 hp |
| VT130.33 | 222 GPM | 3,400 rpm | 650 psi | 1,000 cps | 250 lb-ft | 200 hp |

Behind the Scenes

- Our brand new facility allows us to build our pumps right here in the United States.
- High quality fabrication is done in-house by our team of skilled technicians.
- Our fabrication shop allows us to innovate and develop custom solutions.
- We've invested in the proper equipment to make sure our pumps are produced in a safe and environmentally friendly manner.
- We keep a large supply inventory of spare parts on hand to service your pumps well into the future.
- Having total control of the production process allows us to maintain a high level of quality in our product line.
- Each ViscoTwin pump is rigorously tested before being shipped out to the customer.

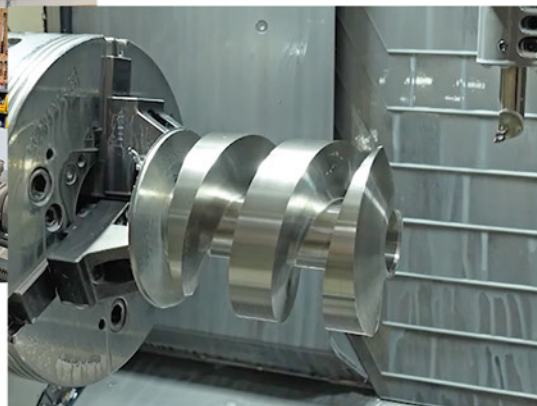

VT Twin Screw Pump: Flow by Viscosity, sample at 80 psi

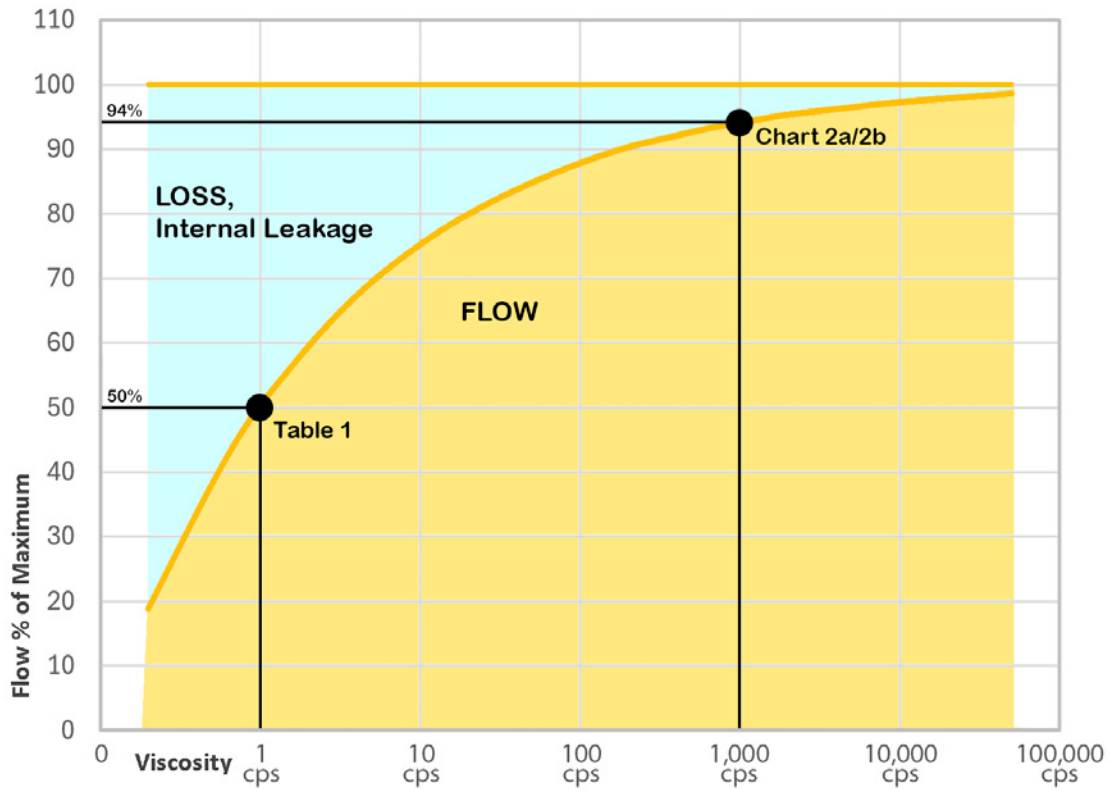

Pumping CIP-Solution @ Viscosity 1cps

TABLE 1

| Model | Pipe Size | Speed in Line | Flow Rate | Discharge Pressure | Shaft Speed | Shaft Torque | Motor 1780 rpm |
|----------|-----------|---------------|-----------|--------------------|-------------|--------------|----------------|
| VT70.22 | OD1.5" | 6.0 ft/sec | 28 GPM | 30 psi | 2,435 rpm | 5.5 lb-ft | 2.0 hp |
| VT70.29 | OD2.0" | 6.0 ft/sec | 51 GPM | 30 psi | 3,130 rpm | 5.5 lb-ft | 2.0 hp |
| VT70.43 | OD2.5" | 6.0 ft/sec | 83 GPM | 30 psi | 3,595 rpm | 7.0 lb-ft | 3.0 hp |
| VT104.27 | OD2.5" | 6.0 ft/sec | 83 GPM | 30 psi | 2,785 rpm | 15.0 lb-ft | 5.0 hp |
| VT104.36 | OD3.0" | 6.0 ft/sec | 121 GPM | 30 psi | 3,118 rpm | 16.5 lb-ft | 7.5 hp |
| VT104.53 | OD3.0" | 6.0 ft/sec | 121 GPM | 30 psi | 2,182 rpm | 16.5 lb-ft | 7.5 hp |
| VT104.53 | OD4.0" | 6.5 ft/sec | 238 GPM | 30 psi | 3,844 rpm | 18.4 lb-ft | 7.5 hp |
| VT130.33 | OD3.0" | 6.0 ft/sec | 121 GPM | 30 psi | 2,088 rpm | 21.7 lb-ft | 7.5 hp |
| VT130.33 | OD4.0" | 6.0 ft/sec | 220 GPM | 30 psi | 3,482 rpm | 21.2 lb-ft | 7.5 hp |
| VT130.44 | OD4.0" | 6.5 ft/sec | 238 GPM | 30 psi | 2,900 rpm | 23.5 lb-ft | 10.0 hp |
| VT130.65 | OD4.0" | 6.5 ft/sec | 238 GPM | 30 psi | 2,090 rpm | 28.0 lb-ft | 10.0 hp |
| VT130.65 | OD5.0" | 6.5 ft/sec | 377 GPM | 30 psi | 3,086 rpm | 27.6 lb-ft | 10.0 hp |
| VT130.65 | OD6.0" | 6.5 ft/sec | 548 GPM | 30 psi | 4,330 rpm | 27.3 lb-ft | 10.0 hp |

Slurries and Concentrates

Viscosity 1000 cps
 Pressure 100 psi
 Shaft Speed 1780 rpm

CHART 2a

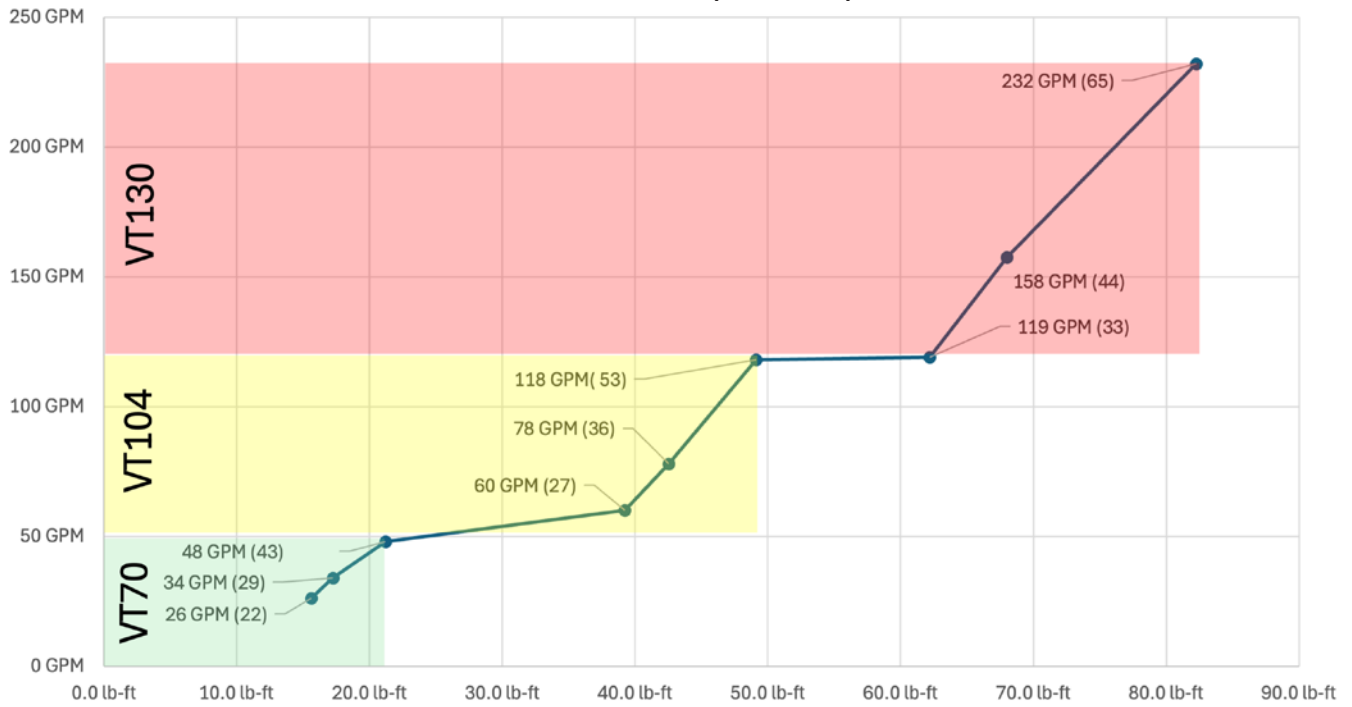

Sensitive Particulates

Viscosity 1000 cps
 Pressure 58 psi
 Shaft Speed 600 rpm

CHART 2b

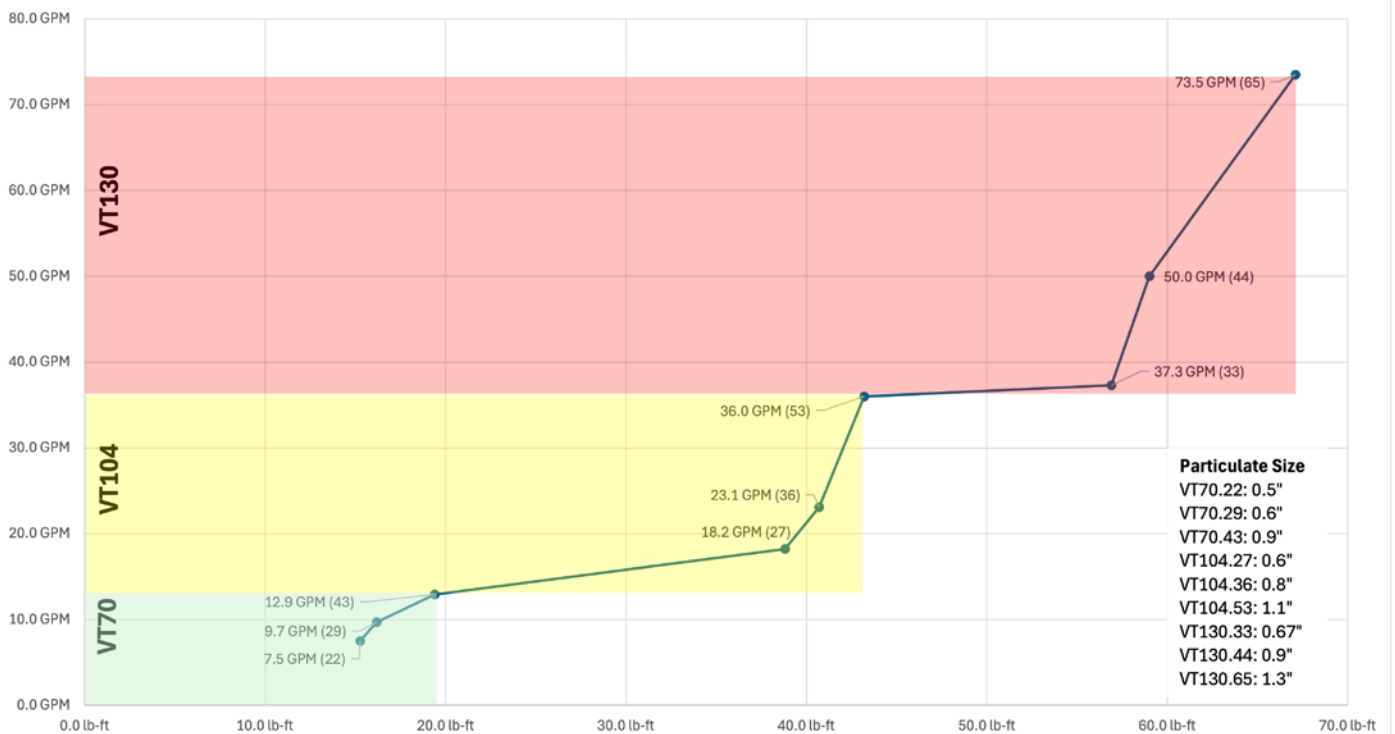

THESE 27 KEY INNOVATIONS FOR THE VISCOTWIN G10 WERE INSPIRED BY ACTUAL IN-FIELD EXPERIENCE FROM PROCESSTEC TECHNICIANS!

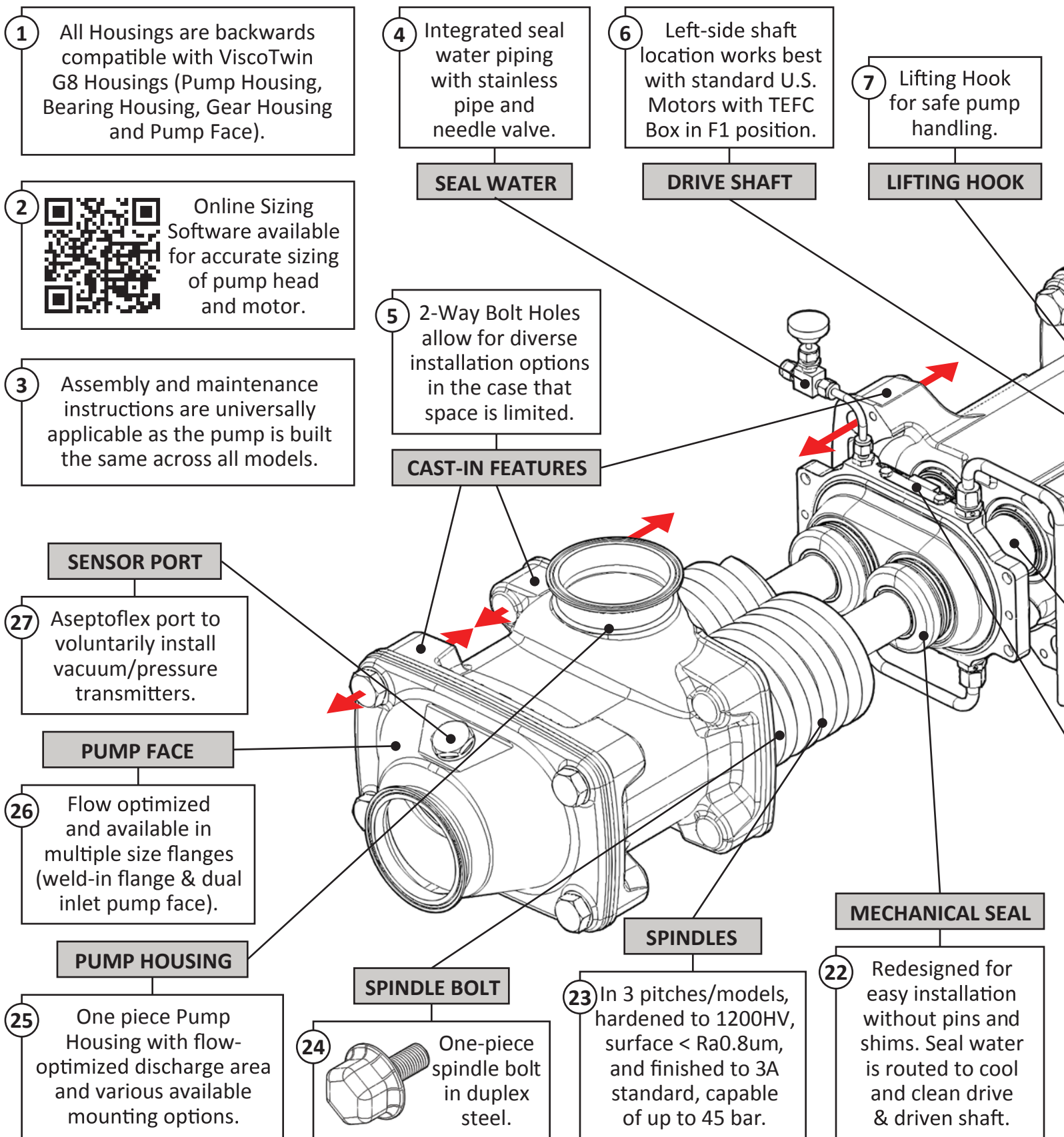

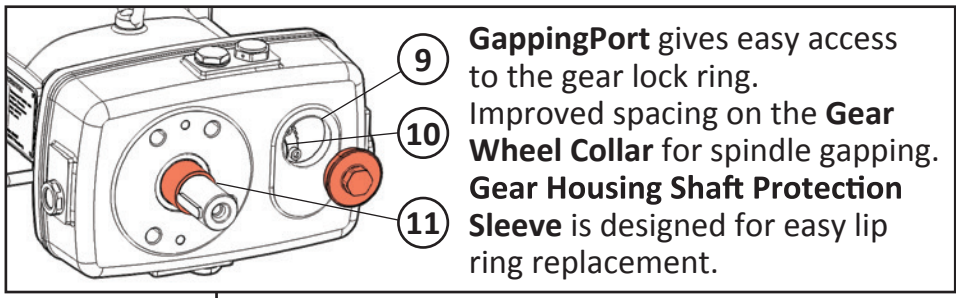

GEAR HOUSING

12 The lantern perfectly aligns the motor coupling and allows the pump to attach to a motor without a pump frame, keeping the coupling accessible for inspection and re-engagement. The lantern stores the Shaft Blocking Tool, and also secures it in place when in use. Perfectly sized for disengaging couplings.

LANTERN

8 Air Vent/
Breather Port with Moisture Filter.

AIR VENT

13 Block mounting for all common motors & gear motors for all ViscoTwin models.

MOTOR

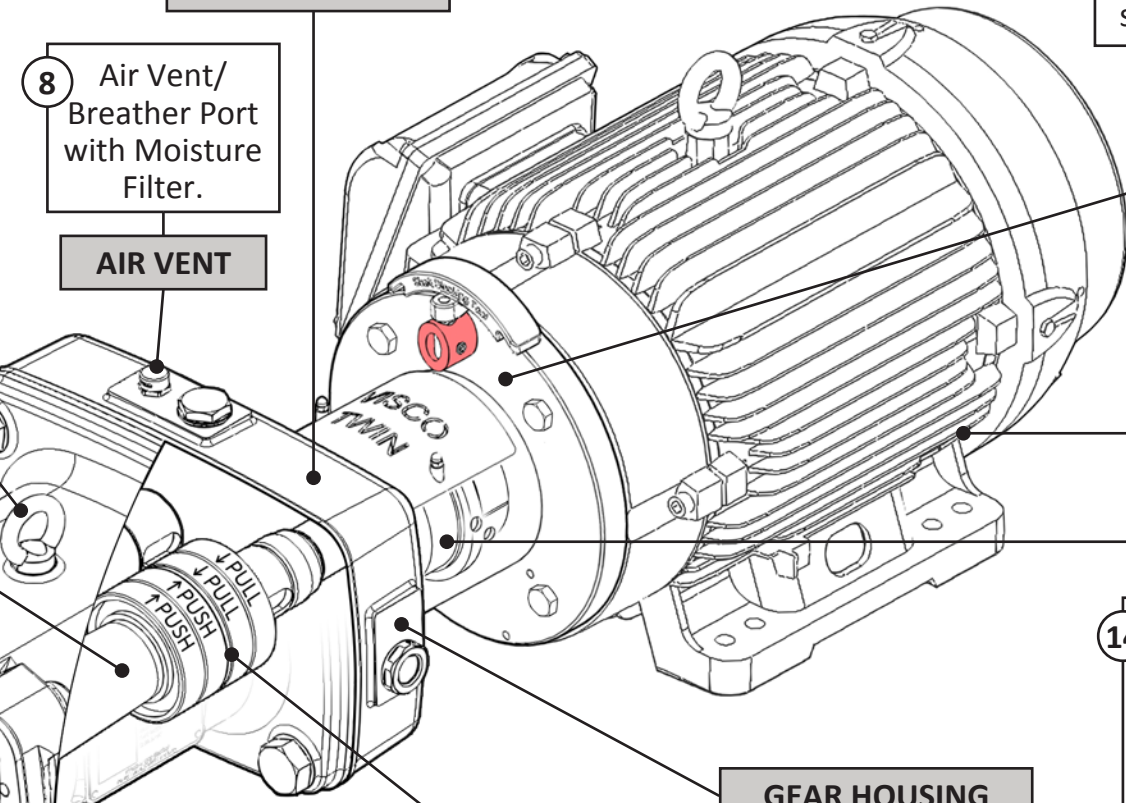

COUPLING OPTIONS

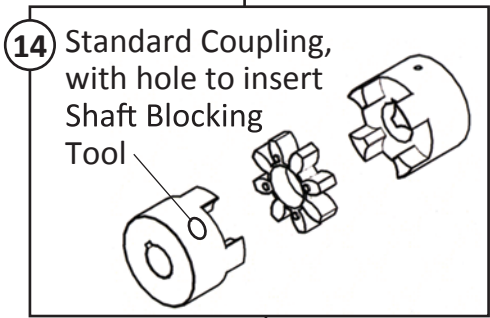

SKF BEARINGS

19 Four (4) Premium **SKF Explorer Series Bearings**, with 2 for pull and 2 for push.

GEAR HOUSING

16 In stainless 1.4308/304, equipped with **oil gauges on each side, 1 gapping port**, 1 oil inlet, 1 oil discharge & 1 breather. The Driven Shaft is left-side mounted by default with an **option for right-side mount**.

17

18

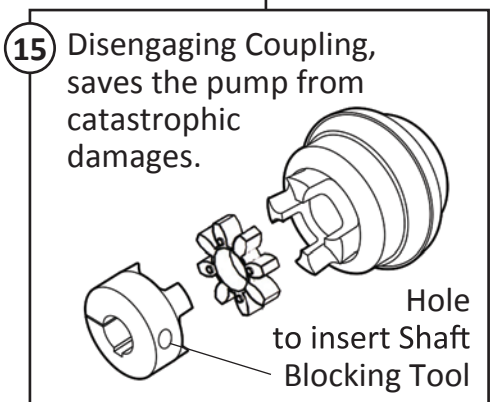

SHAFT PROTECTION SLEEVES

SAFETY GUARD

21 Large one-piece safety guard for easy installation.

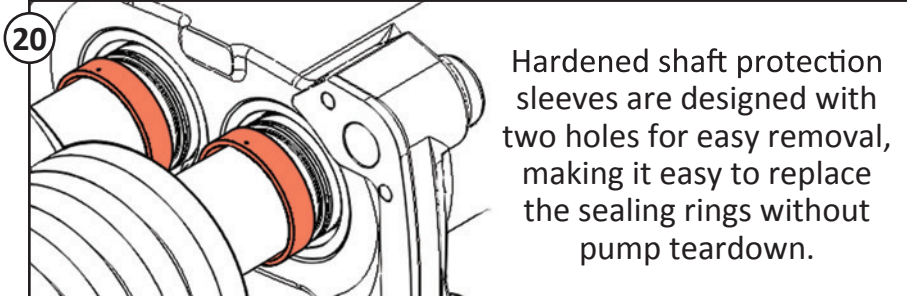

PROCESSTEC
For more information, please contact us at sales@processtec.com

Some of the Industries We Serve



DAIRY



JUICES



FRUITS



PERSONAL
CARE



TOMATO



BEVERAGES



SAUCES



INFANT
FORMULA



PROCESSED
FOODS



PROCESSED
MEAT



BAKERY



CONFECT-
IONERY



PASTRIES



OILS



FRAGRANCE



CHEMICALS



PAINTS



VARNISHES



OINTMENTS



PHARMA-
CEUTICALS



[Pump Sizing
Program](#)

CLICK HERE



VT70 G10



VT104 G10



VT130 G10



PROCESSTEC

GET TOMORROW'S TECHNOLOGY TODAY

PROCESSTEC, Inc.
9938 West Legacy Ave
Visalia, CA 93291

Phone: +1 (559) 429-4227
Fax: +1 (559) 429-4228
Email: info@processtec.com
<http://processtec.com>

Browse the
ViscoTwin
Downloads
Overview Page

