

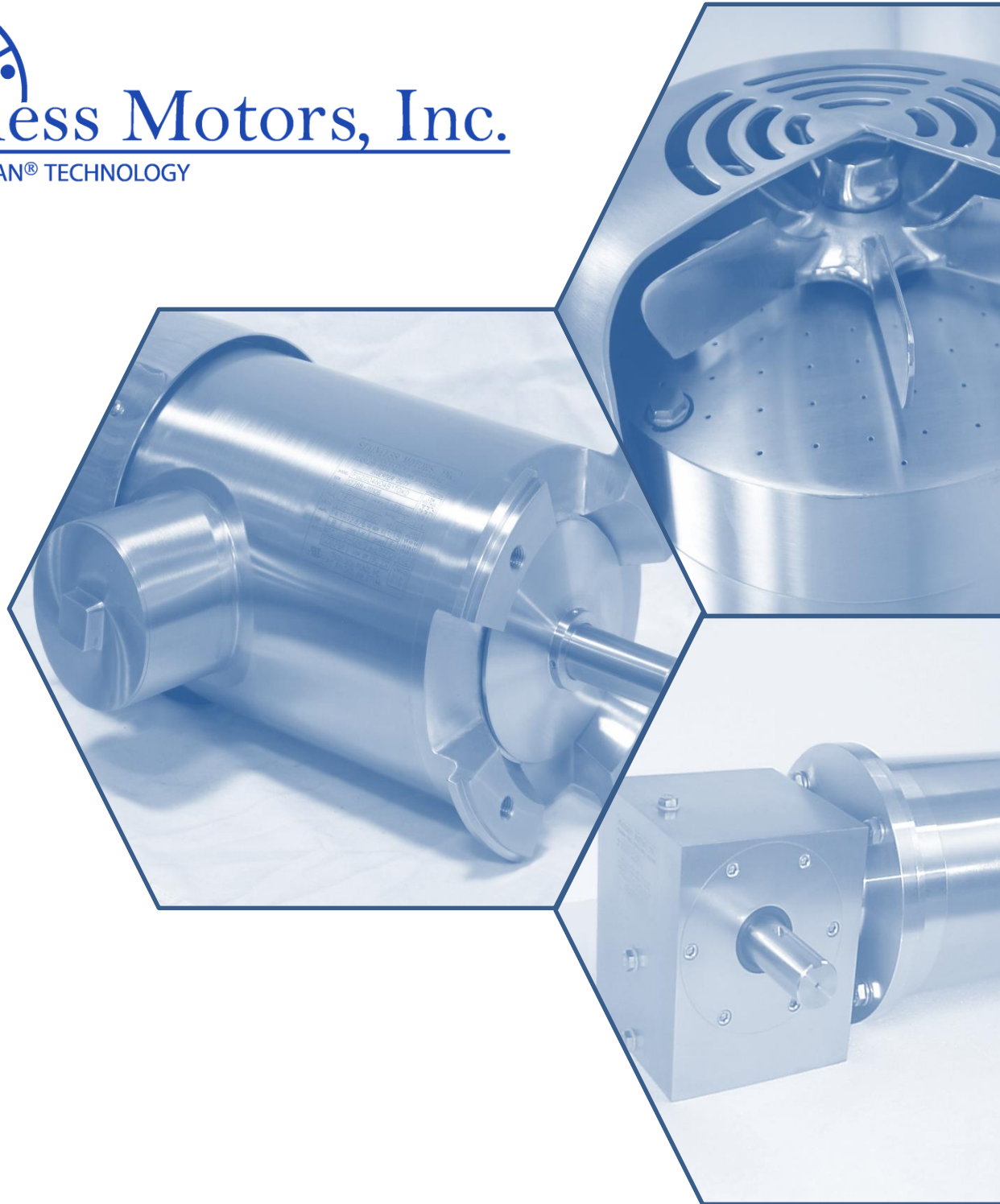

Stainless Motors, Inc.

HOME OF SANIFAN® TECHNOLOGY



STANDARD PRODUCT CATALOG



Stainless Steel Electric Motors | Gear Motors | Specialty Components



Table of Contents

GENERAL INFORMATION

Who We Are2

STAINLESS ELECTRIC MOTORS

The Stainless Motors, Inc. Advantage.....3
Why Sanifan Technology.....4
Three Phase, NEMA Frames.....5
Single Phase, NEMA Frames.....6
IEC Frame Motors.....6

MOTOR OPTIONS

Cooling Options.....7
Foot Options.....7
Sanifan Plus Series Options.....8
Water Port Locations & Connection Options.....8

CUSTOM MANUFACTURING

Vertical Shaft-Up.....9
Pancake Motors.....9
Freezer Duty.....10
Brake Motors.....10
Custom Examples.....10
P-Base Motor.....10

HAZARDOUS LOCATION XP MOTORS

Standard NEMA Frames.....12
Standard IEC Frames.....12

MARINE MOTORS

Standard NEMA Frames.....13

GEARMOTORS

Right Angle Worm Gearmotors.....14
Spiral Bevel Gearmotors.....15
Inline Planetary Gearmotors.....16
Compound Planetary/Spiral Bevel Gearmotors.....17

STAINLESS COUPLINGS

S-Flex Flexible Couplings.....18

REFERENCE

NEMA Reference Chart.....19
NEMA Reference Drawings.....20
IEC Reference Chart.....21
IEC Reference Drawings.....22

CORPORATE INFORMATION

Contact Us.....23

Stainless Motors, Inc. was founded in 1988 to provide the Pharmaceutical, Biotech, and Food processing industries with the first stainless steel washdown duty motors and gear reducers. Since inception, our mission has been to create innovative motors and gear reducers with a focus on quality, reliability, sanitation and high efficiency.

Stainless Motors, Inc. is the exclusive manufacturer of UL approved stainless steel explosion proof hazardous location (XP) motors and Sanifan[®] Technology motors.

Our reputation is built on providing our customers with solutions for their most difficult and severe processing applications. All of our products meet current Good Manufacturing Practice (cGMPs) guidelines for equipment and are designed, manufactured, and supported in the U.S.A. All standard motors meet NEMA MG1, part 31 for inverter performance and are recognized by UL under component file #E135744 for the U.S. and Canada. Hazardous location motors are UL approved under file #E321578.

This catalog presents an overview of our standard product line and is available for download on our website www.stainlessmotors.com. Most product model numbers, drawings and data sheets can be found on our website or you may contact us directly to request this information. Custom solutions are also available by contacting our Applications Engineering Department.

**Your partner for a
cleaner, safer, and more sanitary
processing environment.**



Stainless Motors, Inc. offers a complete line of sanitary stainless steel washdown duty electric motors. All are designed for severe washdown environments and are inverter rated. Sanifan® Technology is standard on all motors and provides a crevice free design that is sanitary and easy to clean. As the original stainless steel motor manufacturer and the exclusive manufacturer of Sanifan® Technology motors, Stainless Motors, Inc. provides quality, performance, reliability and enhanced cleanability.

Our motors are available in a variety of frame sizes and horsepower for most every application. Sanifan® Technology motors are available in 3 phase NEMA TEFC frames up to 50 HP and TENV frames up to 5 HP. We also offer single phase NEMA frames up to 5 HP and 3 phase metric IEC frames up to 22 KW. IEC frames are compliant with EU Legislation and bear the "CE" mark. Our Sanifan® PLUS series offers a spray endbell with various port styles for an even higher level of cleanability. All motors are also available in T316 stainless and can be customized to your unique or specific application.

The Stainless Motors, Inc. Advantage

Sanifan® Technology

The following standard features make our motors the most sanitary and easy to clean stainless motors available. Our unique sanitary design along with exceptional performance and reliability are why we are the industry's preferred stainless electric motor manufacturer.

- Sanitary type 304 stainless steel housing, endbells, feet and junction box
- Polished crevice free stainless cooling fan
- EPDM sanitary fan shroud standoffs
- Sanitary fan to shaft mounting
- EPDM slinger
- Junction box and feet smoothly TIG welded to body
- O-ring sealed stainless endbells
- Crevice free fan shroud mounting
- Sanitary seal on junction box cover
- #4 line finish on all exterior surfaces
- Laser engraved nameplate
- Inverter rated Class F or Class H enhanced insulated windings for superior performance
- Double sealed bearings
- Stainless mechanical shaft seals
- IE3 Efficiency- Premium efficiency
- Available with integral spray cleaning endbell and multiple port styles/configurations (Sanifan® PLUS Series)
- Available with thermostats or thermistors
- Available with Type 316 construction
- Recognized by UL under component file #E135744





Uncompromised Sanitation and Reliability



Sanifan® Plus Series Spray Endbell



Food, Pharmaceutical and Biotech processing requires the utmost level of sanitation and cleanliness. Sanifan® Technology motors are designed to meet these stringent requirements and are the most sanitary stainless steel washdown motors on the market. **Our patented comprehensive solution dramatically reduces crevices that can collect and hold contaminants.** Screw threads, splines and other hardware create opportunities for contamination. Sanifan® Technology provides a means of cleaning previously inaccessible areas.

On conventional motors, contaminants can collect beneath the fan shroud and on the fan. These areas are not accessible for cleaning and can potentially harbor dangerous bacteria. Sanifan Technology's crevice free and easy to clean design helps reduce this risk

Behind the plastic fan

Under the fan shroud



Conventional Design

NEMA FRAMES

Three Phase 230/460V & 575V

HP	RPM	STANDARD NEMA FRAMES
1/4	3450	48, 48C, 56, 56C
	1725	48, 48C, 56, 56C
	1140	56, 56C
	850	56, 56C
1/2	3450	48, 48C, 56, 56C, 56J
	1740	48, 48C, 56, 56C, 56J
	1150	56, 56C
	850	143T, 143TC
3/4	3450	56, 56C, 56J
	1740	56, 56C, 56J
	1150	143T, 143TC
	850	145T, 145TC
1	3450	56, 56C, 56J, 143T, 143TC, 143JM
	1750	56, 56C, 56J, 143T, 143TC, 143JM
	1150	56, 56C, 145T, 145TC
	850	182, 182C, 182T, 182TC
1½	3450	56, 56C, 56J, 143T, 143TC, 143JM
	1750	56, 56C, 56J, 145T, 145TC, 143JM
	1160	182, 182C, 182T, 182TC
	850	184, 184C, 184T, 184TC
2	3450	56, 56C, 145T, 145TC, 56J, 145JM
	1750	56, 56C, 145T, 145TC, 56J, 145JM
	1750	182, 182T, 182C, 182TC
	1160	184, 184T, 184C, 184TC
3	3450	56, 56C, 145T, 145TC, 56J, 145JM
	3500	182, 182C, 182T, 182TC, 182JM
	1760	182, 182C, 182T, 182TC, 182JM
	1160	213, 213T, 213C, 213TC
5	865	215, 215T, 215C, 215TC
	3500	184, 184T, 184C, 184TC, 184JM
	1750	184, 184T, 184C, 184TC, 184JM
	1160	215, 215T, 215C, 215TC
7½	870	254T, 254TC
	3500	184, 184T, 184C, 184TC, 184JM
	3500	213, 213C, 213T, 213TC, 213JM
	1760	213, 213C, 213T, 213TC, 213JM
870	1180	254T, 254TC
	870	256T, 256TC

HP	RPM	STANDARD NEMA FRAMES
10	3500	215, 215T, 215C, 215TC, 215JM
	1760	215, 215T, 215C, 215TC, 215JM
	1180	256T, 256TC
	870	284T, 284TS, 284TC, 284TSC
15	3500	215, 215T, 215C, 215TC, 215JM
	3525	254T, 254TC, 254JM
	1765	254T, 254TC, 254JM
	1180	284T, 284TS, 284TC, 284TSC, 284
20	3525	256T, 256TC, 256JM
	1765	256T, 256TC, 256JM
	1180	286T, 286TC, 286TSC
25	3530	284T, 284TS, 284TC, 284TSC, 284JM
	1780	284T, 284TS, 284TC, 284TSC, 284JM
	1180	324T, 324TS, 324TC, 324TSC
30	3530	286T, 286TS, 286TC, 286TSC, 286JM
	1780	286T, 286TS, 286TC, 286TSC, 286JM
	1180	326T, 326TS, 326TC, 326TSC
40	3540	324T, 324TS, 324TC, 324TSC, 324JM
	1775	324T, 324TS, 324TC, 324TSC, 324JM
50	3540	326T, 326TS, 326TC, 326TSC, 326JM
	1775	326T, 326TS, 326TC, 326TSC, 326JM



½ HP 56C Frame Sanifan Motor with Thru Hole Feet

Please visit our website for model numbers, drawings and data sheets.

Single Phase 115/230V



1/2 HP 56 Frame Single Phase Motor

HP	RPM	SINGLE PHASE NEMA FRAMES
1/4	3450	56, 56C, 56J
	1750	56, 56C, 56J
1/2	3450	56, 56C, 56J
	1750	56, 56C, 56J
3/4	3450	56, 56C, 56J
	1750	56, 56C, 56J
1	3450	56, 56C, 56J, 143T, 143TC, 143JM
	1750	56, 56C, 56J, 143T, 143TC, 143JM
1 1/2	3450	56, 56C, 56J, 143T, 143TC, 143JM
	1750	56, 56C, 56J, 145T, 145TC, 145JM
2	3450	56, 56C, 56J, 145T, 145TC, 145JM
	1750	182, 182C, 182T, 182TC, 182JM
3	3450	182T, 182TC, 182JM
	1750	184T, 184TC, 184JM
5	3450	184T, 184TC, 182JM
	1750	213T, 213TC, 213JM

230/400V, 50Hz & 230/460V, 60Hz "CE"

KW	RPM	STANDARD IEC FRAMES
.37	2850	90-B3, 90-B5, 90-B14
	1450	90-B3, 90-B5, 90-B14
	950	90-B3, 90-B5, 90-B14
	725	90-B3, 90-B5, 90-B14
.75	2850	90-B3, 90-B5, 90-B14
	1450	90-B3, 90-B5, 90-B14
	950	90-B3, 90-B5, 90-B14
	725	112-B3, 112-B5, 112-B14
1.1	2850	90-B3, 90-B5, 90-B14
	1450	90-B3, 90-B5, 90-B14
	950	112-B3, 112-B5, 112-B14
	725	112-B3, 112-B5, 112-B14
1.5	2850	90-B3, 90-B5, 90-B14
	1450	90-B3, 90-B5, 90-B14
	950	112-B3, 112-B5, 112-B14
	725	132-B3, 132-B5, 132-B14
2.2	2850	90-B5, 90-B14, 112-B5, 112-B14
	1450	112-B3, 112-B5, 112-B14
	950	132-B3, 132-B5, 132-B14
	725	132-B3, 132-B5, 132-B14

KW	RPM	STANDARD IEC FRAMES
3.7	2850	112-B3, 112-B5, 112-B14
	1450	112-B3, 112-B5, 112-B14
	950	132-B3, 132-B5, 132-B14
	725	160-B5, 160-B14
5.5	2850	132-B3, 132-B5, 132-B14
	1450	132-B3, 132-B5, 132-B14
	950	160-B5, 160-B14
7.5	2850	132-B3, 132-B5, 132-B14
	1450	160-B5, 160-B14
	950	160-B5, 160-B14
11	2850	160-B5, 160-B14
	1450	160-B5, 160-B14
15	2850	160-B5, 160-B14
	1450	160-B5, 160-B14
18.5	2850	180-B3, 180-B5
	1450	180-B3, 180-B5
22	2850	180-B3, 180-B5
	1450	180-B3, 180-B5

Please visit our website for model numbers, drawings and data sheets.

MOTOR OPTIONS

Cooling Options

A variety of cooling options are available. TEFC and TENV are the most common for pharmaceutical and food processing applications.

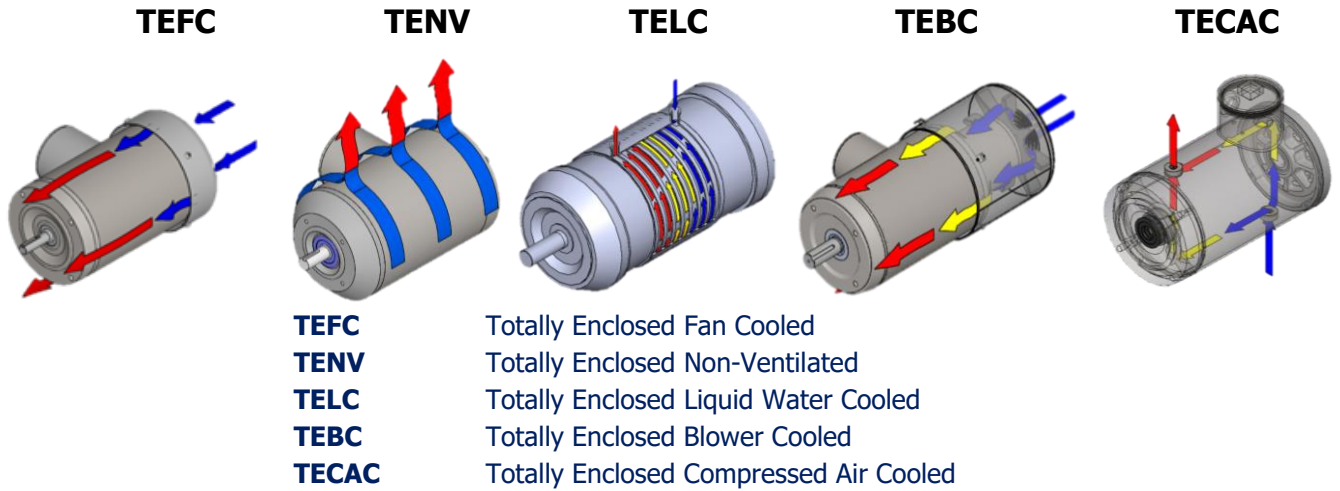

Foot Options

When a foot mount is necessary, we offer two styles – blind tapped and thru hole mount. The blind tapped foot mount is the most sanitary and easy to clean foot option available. It allows crevice free mounting without exposed hardware. Both styles are sanitary stainless steel and are fully TIG welded to the body.



BLIND TAPPED FOOT MOUNT – MOST SANITARY CHOICE



THRU HOLE FOOT MOUNT

Sanifan® PLUS Series

Sanifan® PLUS Series ensures the highest level of cleanability and can be connected directly to an existing CIP system. With Sanifan® PLUS you have the flexibility to select the water port location and port connection style on the endbell that meets the needs of your particular application.



Water Port Locations & Connection Options

Locations are available at 12:00 orientation, 3:00 orientation, 6:00 orientation and 9:00 orientation. For other water port locations, please contact our engineering department.

WATER PORT CONNECTION OPTIONS



Spring Valve



Pipe



Tri Clamp



CUSTOM MANUFACTURING



Vertical Shaft-Up Motors

In addition to standard motors we offer a selection of motors designed and manufactured to solve even the most difficult applications. Our vertical shaft up, freezer duty, dairy and brake motors meet the special applications found in processing environments. Stainless Motors, Inc. also provides unique custom solutions and manufacturing for those one-of-a-kind applications. Contact us today for more information.

VERTICAL SHAFT UP APPLICATIONS

Vertical shaft-up (W8) applications present a special challenge for washdown duty motors. Any recess in the shaft-end endbell will pool water and increase the risk of water entry past the shaft seal. Stainless Motors, Inc. has solved this challenge by developing a motor with an optimized, tapered endbell and an O-ring sealed rotating shield. Together they virtually eliminate shaft seal problems in vertical shaft-up applications. As with all Stainless Motors, Inc. motors, they may be ordered with the junction box in various locations, and the conduit port facing up, down, left or right permitting the cleanest installation.



1 HP 56 Frame Motor, TENV with Thru Hole Feet



5 HP 184TC Frame Motor TEFC, Footless



1 HP 56C Frame Motor, Single Phase TENV, Custom Flange



Pancake Motors

These motors meet the strict USDA and 3-A Sanitary Standards for dairy applications. Properly constructed, gasketed junctures and a smooth, stainless steel body with #4 finish free of pits, cracks, folds and other imperfections. There are no exposed threads and it is specially designed to meet the USDA requirements.



CUSTOM MANUFACTURING

Freezer Duty Motors

When temperatures of -40°C and below are present, unique challenges are created for stainless steel motors. Two possible obstacles include thermal expansion rate of the metals and low temperature elastomer stiffening. Stainless Motors, Inc. has optimized design parameters and materials, including low temperature arctic grease, EPDM O-rings, labyrinth seals with silicon outer O-rings, and tolerance rings for these extreme temperature applications.



Brake Motors

For applications requiring power-off torque holding, Stainless Motors, Inc. integrates a stainless steel housed, spring set brake with our motors. Our brake motors feature torque ratings from 6 - 124, ft – lbs. power off operation, and an optional manual release that automatically resets. All brake leads are brought out to the junction box allowing for a single conduit electrical connection and enhancing machine integration and cleanability.



Custom Manufacturing Examples



Custom Mounting Adapter



Integral Tach Motor



Counter Rotating Motor/Gear Motor

P-BASE MOTOR WITH CUSTOM SHAFT

STAINLESS
MOTORS INC

Vertical shaft down P-Base motors for applications in water treatment, irrigation pumps, and in the petrochemical industry, designed for washdown and high humidity environments. The example shown below includes custom lifting tabs, an extended T316 stainless shaft with a threaded end, and is used in water treatment aeration.



Stainless Motors, Inc. developed the first washdown duty stainless steel motors approved for use by UL in Hazardous Locations. These motors are suitable for use in the most critical areas of the Pharmaceutical, Biotech and Food Processing industries where cleanliness, washdown tolerance, and safety concerns due to hazardous liquids, vapors or dust exist. These motors are all approved for use with PWM inverters.

All of our explosion proof motors have thermostats in the windings for over temperature protection. These motors are rated temperature code T3B (165°C, 329°F).

Our Hazardous Location "XP" motors are approved for Class I, Division 1, Groups C & D and Class II, Division 1, Groups F & G. UL File #E321578.

HP	RPM	Standard NEMA Frames 230/460V
1/2	3450	56, 56C
	1750	56, 56C
1	3450	56, 56C, 143T, 143TC, 143JM
	1750	56, 56C, 143T, 143TC, 143JM
1½	3450	56, 56C, 143T, 143TC, 143JM
	1750	56, 56C, 145T, 145TC, 145JM
2	3450	56, 56C, 145T, 145TC, 145JM
	1750	56, 56C, 145T, 145TC, 145JM
3	3450	56, 56C, 145T, 145TC, 145JM
	3500	182, 182C, 182T, 182TC, 182JM
	1750	182, 182C, 182T, 182TC, 182JM
5	3500	184, 184C, 184T, 184TC, 184JM
	1750	184, 184C, 184T, 184TC, 184JM

KW	RPM	Standard IEC Frames 230/460V
.37	3450	90-B3, 90-B5*, 90-B14
	1750	90-B3, 90-B5*, 90-B14
.75	3450	90-B3, 90-B5*, 90-B14
	1750	90-B3, 90-B5*, 90-B14
1.1	3450	90-B3, 90-B5*, 90-B14
	1750	90-B3, 90-B5*, 90-B14
1.5	3450	90-B3, 90-B5*, 90-B14
	1750	90-B3, 90-B5*, 90-B14
2.2	3500	90-B3, 90-B5*, 90-B14
	1750	112-B3, 112-B5, 112-B14
3.7	3500	112-B3, 112-B5, 112-B14
	1750	112-B3, 112-B5, 112-B14

*90-B5 frame has a 250mm flange



Please visit our website for model numbers, drawings and data sheets.

MARINE MOTORS IN T316 STAINLESS

Our Marine series motors are designed for the rigorous salt water environments found aboard ships and yachts. These motors provide the ultimate in reliability and appearance whether mounted on a salt sprayed deck or within the hot confines of an engine room or bilge. Single phase models feature high efficiency capacitor start, capacitor run design and an electronic starting switch which eliminates the failure prone mechanical switch used on general purpose industrial motors. Rugged, high efficiency design ensures reliability and performance while the compact design allows for efficient allocation of space. Common shipboard applications include driving air conditioning recirculation pumps, fuel and oil transfer pumps, macerator pumps and dive compressors. Single Phase marine motors are available up to 5 HP, 115/230V.

HP	RPM	Standard NEMA Frames 230/460V
1/4	3450	48, 48C, 56, 56C, 56J
	1750	48, 48C, 56, 56C, 56J
1/2	3450	48, 48C, 56, 56C, 56J
	1750	48, 48C, 56, 56C, 56J
3/4	3450	56, 56C, 56J
	1750	56, 56C, 56J
1	3450	56, 56C, 56J, 143T, 143TC, 143JM, 143JP
	1750	56, 56C, 56J, 143T, 143TC, 143JM, 143JP
1½	3450	56, 56C, 56J, 143T, 143TC, 143JM, 143JP
	1750	56, 56C, 56J, 145T, 145TC, 145JM, 145JP
2	3450	56, 56C, 56J, 145T, 145TC, 145JM, 145JP
	1750	182, 182T, 182TC, 182JM, 182JP
3	3450	182, 182T, 182TC, 182JM, 182JP
	1750	184, 184T, 184TC, 184JM, 184JP

HP	RPM	Standard NEMA Frames 230/460V
5	3450	184, 184T, 184TC, 184JM, 184JP
	1750	213T, 213TC, 213JM, 213JP
7½	3450	213T, 213TC, 213JM, 213JP
	1750	213T, 213TC, 213JM, 213JP
10	3450	215T, 215TC, 215JM, 215JP
	1750	215T, 215TC, 215JM, 215JP
15	3450	254T, 254TC, 254JM, 254JP
	1750	254T, 254TC, 254JM, 254JP
20	3450	256T, 256TC, 256JM, 256JP
	1750	256T, 256TC, 256JM, 256JP
25	3450	284T, 284TC, 284JM, 284JP
	1750	284T, 284TC, 284JM, 284JP
30	3450	286T, 286TC, 286JM, 286JP
	1750	286T, 286TC, 286JM, 286JP



Please visit our website for model numbers, drawings and data sheets.

Our Right Angle Worm Drive gear reducers feature hardened and ground worms and aluminum-bronze worm gears for high capacity and long life. Gearboxes are machined and ground to a sanitary #4 finish on all surfaces. Single, double and hollow bore output shafts are available with right-hand, left-hand and vertical assembly options. Larger RA gearboxes with vertical output shafts feature our Positive Pressure Lubrication System ensuring that all bearings and gears are well lubricated even at very low rotational speeds. Purity FG EP 460 (USDA H1) synthetic lubricant provides exceptional lubrication and extended life performance. All RA units can be fitted with optional flange mounts with either standard C-face or customer specified dimensions.

- Compact, Right Angle Drive
- For Ratios between 5:1 and 60:1
- Typical applications - Positive displacement pumps, mixers, and conveyor drives

Ratio	Output RPM	¼ HP	½ HP	1 HP	1½ HP	2 HP	3 HP	5 HP	7½ HP	10 HP
5	348	RA133	RA175	RA175	RA175	RA206	RA262	RA325	RA375	RA450
7.5	232	RA133	RA175	RA175	RA206	RA262	RA325	RA375	RA450	RA520
10	174	RA133	RA175	RA206	RA262	RA262	RA325	RA375	RA450	RA520
15	116	RA133	RA175	RA206	RA262	RA325	RA375	RA450	RA520	
20	87	RA133	RA175	RA262	RA262	RA325	RA375	RA520		
25	70	RA133	RA175	RA262	RA262	RA375	RA450	RA520		
30	58	RA133	RA206	RA325	RA325	RA375	RA450			
40	44	RA175	RA206	RA325	RA375	RA450	RA520			
50	35	RA175	RA206	RA325	RA375	RA450	RA520			
60	29	RA175	RA262	RA325	RA375	RA450	RA520			

RA OUTPUT SHAFT DIAMETER RANGE

Gearbox	Solid Shaft		Hollow Bore		
	Min	Max	Min	Max W/Key	Max No Key
RA133	½"	1-1/8"	½"	⅝" x 3/16"	3/4"
RA175	⅝"	1-3/8"	¾"	⅞" x 3/16"	1"
RA206	⅞"	1-3/4"	¾"	1-1/4" x ¼"	1-1/4"
RA262	1"	2"	1"	1-7/16" x ⅜"	1-1/2"
RA325	1-3/8"	2-3/4"	1"	1-7/8" x ½"	2-1/8"
RA375	1-1/2"	2-7/8"	1½"	2" x ½"	2-1/8"
RA450	1-5/8"	4-3/4"	1½"	2-3/8" x ⅝"	2-3/4"
RA520	1-5/8"	4-3/4"	2"	3-7/8" x ¾"	3-3/4"



SPIRAL BEVEL GEARMOTORS

Spiral Bevel reducers provide high efficiency and quiet operation in low ratios. Spiral Bevel gearmotors are built as integral gearmotors, with the pinion gear mounted directly on a modified motor shaft. Right-hand, left-hand and vertical assembly options are available.

- Output shaft at right angle to the input shaft
- Required ratio is between 1:1 and 4:1
- Excellent efficiency
- Furnished with C-face or flange mount output faces
- Typical applications include positive displacement pump drives and tank mounted mixer drives where low headroom exists

Ratio	Output RPM	½ HP	1 HP	1½ HP	2 HP	3 HP	5 HP	7½ HP	10 HP	15 HP	20 HP
1:1	1740	SB56	SB56	SB56	SB56	SB180	SB180	SB210	SB210	SB250	SB250
1.5:1	1160	SB56	SB56	SB56	SB56	SB180	SB180	SB210	SB210	SB250	SB250
2:1	870	SB56	SB56	SB56	SB56	SB180	SB180	SB210	SB210	SB250	SB250
3:1	580	SB56	SB56	SB56	SB56	SB180	SB180	SB210	SB210	SB250	SB250
4:1	435	SB56	SB56	SB56	SB56						



Efficient and compact, our Inline Planetary gearmotors feature cast T304 housings with sanitary foot mounts. GMP design is evident in the smooth, cylindrical shape and integral motor interface. All outer surfaces are fully machined and ground for a superior sanitary finish. Custom modifications such as a flange or C-face mount, or altered shaft dimension are readily produced to order. High ratio units feature unique compound gearing to produce very low output speeds with a compact reducer.

- Output shaft that is concentric with the motor input shaft
- Cylindrical, very aesthetic, compact, and cleanable gearmotor
- Standard ratios are between 3:1 to 25:1
- Extremely high ratios are possible (1000:1 or more)
- Planetary gearmotors available as:
 - Foot mounted (typical for driving positive displacement pumps)
 - C-face or flange-mounted unit, as would be preferred for such applications as tank mounted mixers

IL570 RATIOS ½ HP MAX

RATIO	3.17	3.6	4.25	5.33	10.05	11.41	12.96	13.47	15.3	16.89	18.06	19.18	22.65	28.4
OUTPUT	548	483	409	326	173	152	134	129	113	103	96	90	76	61

Ratio	Output RPM	½-1 HP	1½ HP	2 HP	3 HP	5 HP	7½ HP	10 HP	15 HP	20 HP	25 HP	30 HP
3	580	IL650	IL650	IL650	IL650	IL880	IL880	IL880	IL1000	IL1000	IL1275	IL1275
3.67	474	IL650	IL650	IL650	IL650	IL880	IL880	IL880	IL1000	IL1000	IL1275	IL1275
4.2	414	IL650	IL650	IL650	IL650	IL880	IL880	IL880	IL1000	IL1000	IL1275	IL1275
5	348	IL650	IL650	IL650	IL650	IL880	IL880	IL880	IL1000	IL1000	IL1275	IL1275
6.33	275	IL650	IL650	IL650	IL650	IL880	IL880	IL880	IL1000	IL1000	IL1275	IL1275
7.8	223	IL650	IL650	IL650	IL650	IL880	IL880	IL880	IL1000	IL1000	IL1275	IL1275
9	193	IL650	IL650	IL650	IL650	IL880	IL880	IL880	IL1000	IL1000	IL1275	IL1275
11	158	IL650	IL650	IL650	IL650	IL880	IL880	IL880	IL1000	IL1000	IL1275	IL1275
12.6	138	IL650	IL650	IL650	IL880	IL880	IL880	IL880	IL1000	IL1000	IL1275	IL1275
15	116	IL650	IL650	IL650	IL880	IL880	IL880	IL880	IL1000	IL1000	IL1275	IL1275
17.6	98	IL650	IL650	IL650	IL880	IL880	IL880	IL1000	IL1000	IL1000	IL1275	IL1275
21	82	IL650	IL650	IL880	IL880	IL880	IL880	IL1000	IL1000	IL1000	IL1275	IL1275
25	69	IL650	IL880	IL880	IL880	IL880	IL880	IL1000	IL1000	IL1275	IL1275	IL1275



COMPOUND PLANETARY / SPIRAL BEVEL GEARMOTOR

Our innovative SBT series combines our proven IL planetary series technology with a high capacity spiral bevel gear set in a unique and ultra-cleanable tubular housing. All vertical output shaft models feature our Positive Pressure Lubrication System ensuring that all bearings and gears are well lubricated, even at very low rotational speeds. Purity FG EP 460 (USDA H1) synthetic lubricant provides exceptional lubrication and extended life performance. SBT units are made to order allowing OEM's and end-users to specify a particular mounting configuration for the best possible integration with new or existing equipment. The tubular housing features smooth, easily cleanable surfaces and is often equipped with a flange or C-face mounting. The output shaft of SBT units is at right angle to the motor shaft.

- Compact and highly efficient
- High ratio, high power applications
- Output shaft at right angle to input shaft
- Output Shafts
- Solid or Hollow bore
- Vertical or Horizontal orientation

Output RPM Range	5 HP	7.5 HP	10 HP	15 HP	20 HP	25 HP	30 HP	40 HP
71-200	SBT1000	SBT1100	SBT1200	SBT1300	SBT1400	SBT1600	SBT1600	SBT2000
51-70	SBT1100	SBT1200	SBT1300	SBT1400	SBT1600	SBT1800	SBT1800	SBT2000
36-50	SBT1200	SBT1300	SBT1400	SBT1600	SBT1600	SBT2000	SBT2000	SBT2200
27-35	SBT1300	SBT1400	SBT1600	SBT1800	SBT2000	SBT2200	SBT2200	SBT2400
17-26	SBT1400	SBT1600	SBT1600	SBT2000	SBT2200	SBT2400	SBT2600	SBT2600
12-16	SBT1600	SBT2000	SBT2000	SBT2400	SBT2600	SBT2600	SBT2800	SBT2800
10-11	SBT1800	SBT2000	SBT2200	SBT2400	SBT2800	SBT2800	SBT2800	SBT2800
9-10	SBT2000	SBT2200	SBT2400	SBT2600	SBT2800	SBT2800	SBT2800	SBT2800



We offer S-Flex Style flexible couplings with the same corrosion resistance as our motors. Made of stainless steel, they are suitable for washdown locations and can be specially made to fit your application. Hubs are bored to size, inch or metric.

S-Flex Style	Bore Range		Load Rating
	Inch	mm	
SS5S	.625-1.125"	16mm-28mm	.0038
SS6S	.625-1.250"	16mm-32mm	.0071
SS7S	.625-1.625"	16mm-41mm	.012
SS8S	1.250-1.875"	32mm-48mm	.018
SS9S	1.250-2.250"	32mm-57mm	.028
SS10S	1.500-2.750"	38mm-70mm	.046
SS11S	1.500-3.250"	38mm-82mm	.072
SS12S	1.500-3.625"	38mm-98mm	.114
SS13S	1.500-4.500"	38mm-115mm	.18
SS14S	1.500-5.000"	38mm-127mm	.286
SS16S	1.500-5.500"	38mm-140mm	.75

How to determine the Load Rating

Divide the horsepower of the motor by the RPM of the coupling.



NEMA QUICK REFERENCE CHART

NEMA Frame Designation	Frame Dimensions (inches)									
	D	E	2F	U	V	C-Face AH	C-Face AJ	AK	BA	BD
48	3	2 1/8	2 3/4	1/2	1 1/2	1 11/16	3 3/4	3	2 1/2	5 5/8
48C	3	2 1/8	2 3/4	1/2	1 1/2	1 1/2	3 3/4	3	2 1/2	5 5/8
56	3 1/2	2 7/16	3	5/8	1 7/8	2 1/16	5 7/8	4 1/2	2 3/4	6 1/2
56C	3 1/2	2 7/16	3	5/8	1 7/8	1 7/8	5 7/8	4 1/2	2 3/4	6 1/2
143T	3 1/2	2 3/4	4	7/8	2 1/4	2 1/8	5 7/8	4 1/2	2 1/4	6 1/2
143TC	3 1/2	2 3/4	4	7/8	2 1/4	2 1/8	5 7/8	4 1/2	2 3/4	6 1/2
145T	3 1/2	2 3/4	5	7/8	2 1/4	2 1/8	5 7/8	4 1/2	2 1/4	6 1/2
145TC	3 1/2	2 3/4	5	7/8	2 1/4	2 1/4	5 7/8	4 1/2	2 3/4	6 1/2
182	4 1/2	3 3/4	4 1/2	7/8	2 1/4	2 1/8	5 7/8	4 1/2	2 3/4	6 1/2
182C	4 1/2	3 3/4	4 1/2	7/8	2 1/4	2 1/8	5 7/8	4 1/2	3 1/2	6 1/2
182T	4 1/2	3 3/4	4 1/2	1 1/8	2 3/4	2 5/8	7 1/4	8 1/2	2 3/4	9
182TC	4 1/2	3 3/4	4 1/2	1 1/8	2 3/4	2 3/4	7 1/4	8 1/2	3 1/2	6 1/2
184	4 1/2	3 3/4	5 1/2	7/8	2 1/4	2 1/8	5 7/8	4 1/2	2 3/4	6 1/2
184TC	4 1/2	3 3/4	5 1/2	1 1/8	2 3/4	2 3/4	7 1/4	8 1/2	3 1/2	6 1/2
184T	4 1/2	3 3/4	5 1/2	1 1/8	2 3/4	2 5/8	7 1/4	8 1/2	2 3/4	9
213	5 1/4	4 1/4	5 1/2	1 1/8	3	2 3/4	7 1/4	8 1/2	3 1/2	9
213C	5 1/4	4 1/4	5 1/2	1 1/8	3	2 3/4	5 7/8	8 1/2	3 1/2	9
213T	5 1/4	4 1/4	5 1/2	1 3/8	3 3/8	3 1/8	7 1/4	8 1/2	3 1/2	9
213TC	5 1/4	4 1/4	5 1/2	1 3/8	3 3/8	3 3/8	7 1/4	8 1/2	4 1/4	9
215	5 1/4	4 1/4	7	1 1/8	3	2 3/4	7 1/4	8 1/2	3 1/2	9
215T	5 1/4	4 1/4	7	1 3/8	3 3/8	3 1/8	7 1/4	8 1/2	3 1/2	9
215TC	5 1/4	4 1/4	7	1 3/8	3 3/8	3 3/8	7 1/4	8 1/2	4 1/4	9
254T	6 1/4	5	8 1/4	1 5/8	3 3/4	3 3/4	7 1/4	8 1/2	4 1/4	10
254TC	6 1/4	5	8 1/4	1 5/8	3 3/4	4	7 1/4	8 1/2	4 3/4	10
256T	6 1/4	5	10	1 5/8	3 3/4	3 3/4	7 1/4	8 1/2	4 1/4	10
256TC	6 1/4	5	10	1 5/8	3 3/4	4	7 1/4	8 1/2	4 3/4	10
284T	7	5 1/2	9 1/2	1 7/8	4 5/8	4 3/8	9	10 1/2	4 3/4	11 1/4
284TC	7	5 1/2	9 1/2	1 7/8	4 5/8	4 5/8	9	10 1/2	4 3/4	11 1/4
284TS	7	5 1/2	9 1/2	1 5/8	3 1/4	3	9	10 1/2	4 3/4	11 1/4
286T	7	5 1/2	11	1 7/8	4 5/8	4 3/8	9	10 1/2	4 3/4	11 1/4
286TC	7	5 1/2	11	1 7/8	4 5/8	4 5/8	9	10 1/2	4 3/4	11 1/4
286TS	7	5 1/2	11	1 5/8	3 1/4	3	9	10 1/2	4 3/4	11 1/4
324T	8	6 1/4	10 1/2	2 1/8	5 1/4	5	11	12 1/2	5 1/4	13 3/8
324TS	8	6 1/4	10 1/2	1 7/8	3 3/4	3 1/2	11	12 1/2	5 1/4	13 3/8
326T	8	6 1/4	12	2 1/8	5 1/4	5	11	12 1/2	5 1/4	13 3/8
326TS	8	6 1/4	12	1 7/8	3 3/4	3 1/2	11	12 1/2	5 1/4	13 3/8
364T	9	7	11 1/4	2 3/8	5 7/8	5 5/8	11	12 1/2	5 7/8	13 3/8
364TS	9	7	11 1/4	1 7/8	3 3/4	3 1/2	11	12 1/2	5 7/8	13 3/8
365T	9	7	12 1/4	2 3/8	5 7/8	5 5/8	11	12 1/2	5 7/8	13 3/8
365TS	9	7	12 1/4	1 7/8	3 3/4	3 1/2	11	12 1/2	5 7/8	13 3/8

STANDARD

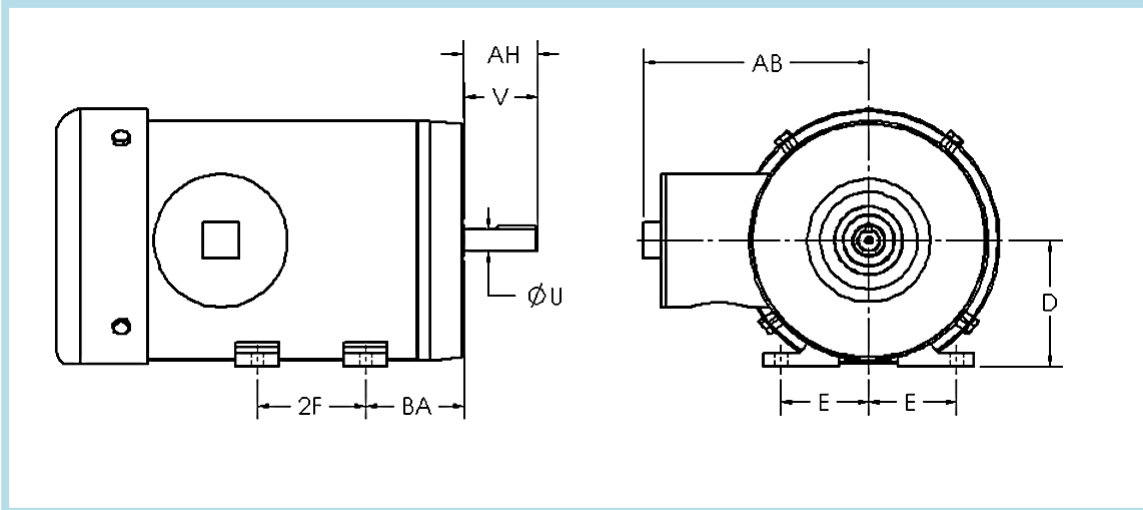

C-FACE

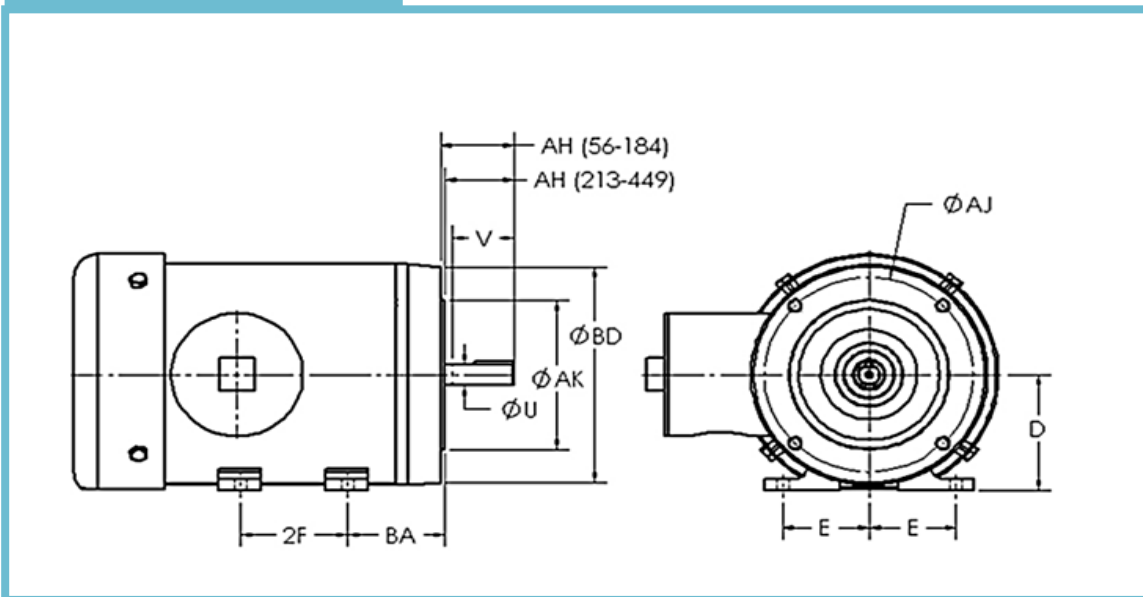

IEC QUICK REFERENCE CHART

IEC Frame Designation	Frame Dimensions (millimeters)																			
	Footed					B5 Flange						B14 Face					General			
	A	B	H	D	E	LA	M	N	P	S	T	M	N	P	S	T	AC	AD	HC	XX
80	125	100	50	19	40	13	165	130	200	11	3.5	100	80	120	M6	3	145	116	152	22
90S	140	100	56	24	50	13	165	130	200	12	3.5	115	95	140	M8	3	119	130	173	22
90L	140	125	56	24	50	13	165	130	200	12	3.5	115	95	140	M8	3	119	130	173	22
100S	160	112	63	28	60	14	215	180	250	14	4	130	110	160	M8	3.5	102	149	180	27
100L	160	140	63	28	60	14	215	180	250	14	4	130	110	160	M8	3.5	102	149	180	27
112S	190	114	70	28	60	14	215	180	250	14	4	130	110	160	M8	3.5	116	149	214	27
112L	190	140	70	28	60	14	215	180	250	14	4	130	110	160	M8	3.5	130	149	214	27
132S	216	140	89	38	80	14	265	230	300	14	4	165	130	200	M8	3.5	149	187	256	27
132L	216	178	89	38	80	14	265	230	300	14	4	165	130	200	M8	3.5	243	187	256	27
160M	254	210	108	42	110	20	300	250	350	19	5	215	180	250	M12	4	329	242	329	35
160L	254	254	108	42	110	20	300	250	350	19	5	215	180	250	M12	4	329	242	329	35
180M	279	241	121	48	110	20	300	250	350	19	5						395	333	372	51
180L	279	279	121	48	110	20	300	250	350	19	5						395	333	372	51
200M	318	267	133	55	110	27	350	300	400	19	5						441	359	416	63
200L	318	305	133	55	110	27	350	300	400	19	5						441	359	416	63
225S	356	286	149	60	140	19	400	350	450	19	6						495	383	483	63
225M	356	311	149	60	140	19	400	350	450	19	6						495	383	483	63
250S	406	311	168	70	140												520	457	513	63
250M	406	349	168	70	140												520	457	513	63
280S	457	368	190	80	170												616	497	581	63
80M	457	419	190	80	170												616	497	581	63
315S	508	406	216	85	170												759	683	682	102
315M	508	457	216	85	170												759	683	682	102
355S	610	500	254	85	170												759	683	719	102
355L	610	630	254	85	170												759	683	719	102

FOOTED

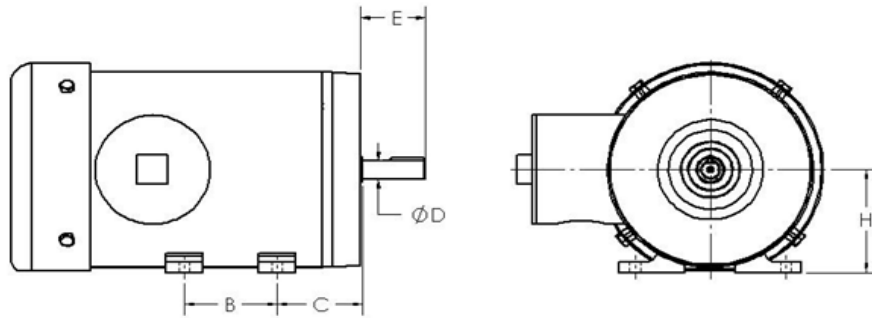

B5 FLANGE

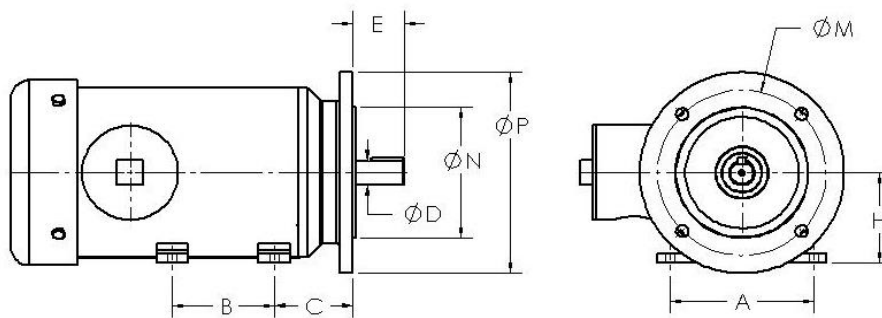

B14 FACE

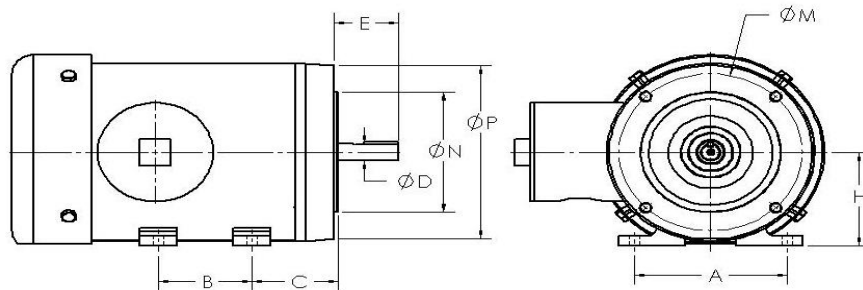

Contact Us

STAINLESS MOTORS, INC

Corporate Office & Manufacturing Facility
7601 Nita Place NE
Rio Rancho, N.M. 87144 USA

Main: 505-867-0224
Fax: 505-867-0225
Sales: 505-867-7100
Email: Sales@stainlessmotors.com
Website: www.stainlessmotors.com

Follow us on:



Please visit our website for model numbers, drawings and data sheets.

Your partner for a cleaner, safer and more sanitary processing environment



Sanifan® is a registered trademark of Stainless Motors, Inc.

StainlessMotors.com



(505) 867-0224