



PROCESSTEC

GET TOMORROW'S TECHNOLOGY TODAY

ViscoTwin 104 G10

Operation & Maintenance Manual

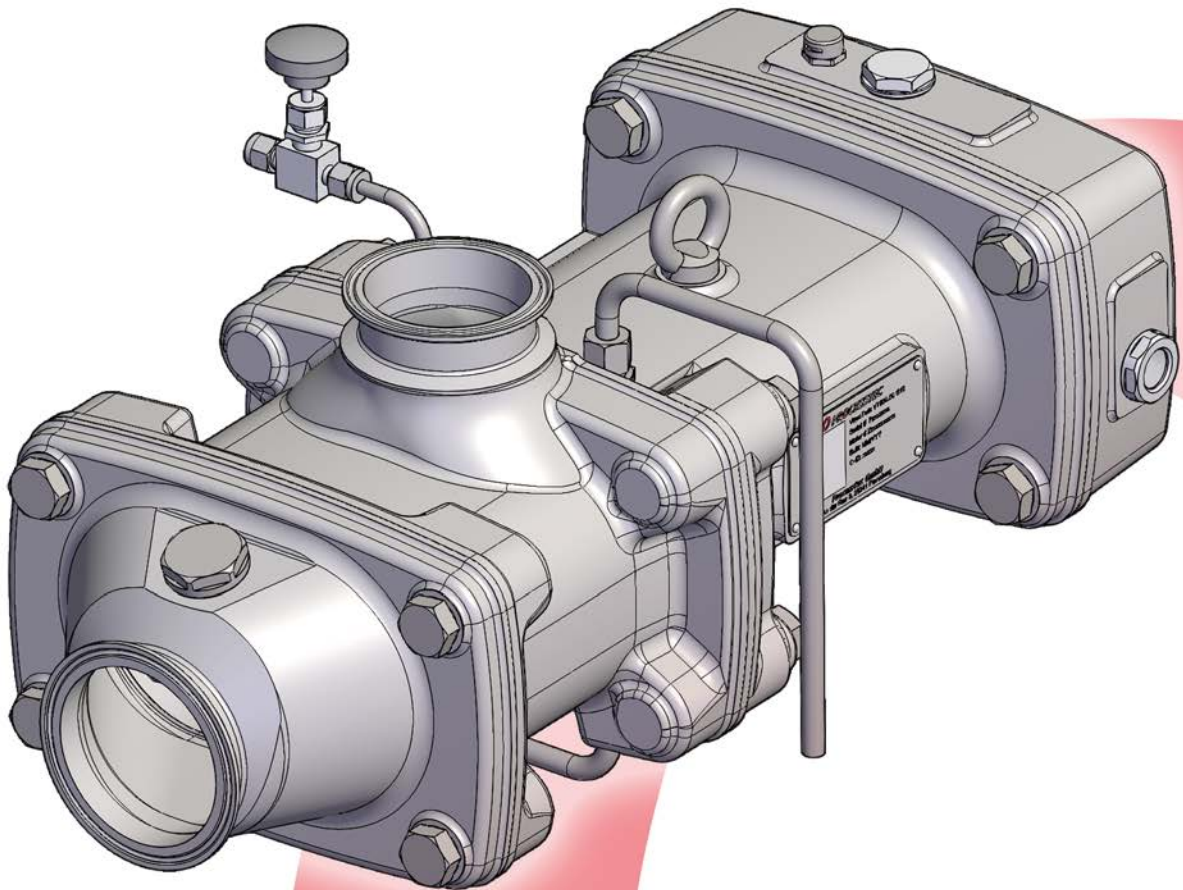

Address: 9938 West Legacy Ave | Visalia, CA 93291 | Phone: +1 (559) 429-4227
Fax: +1 (559) 429-4228 | Email: info@processtec.com | <http://processtec.com>

1. ABOUT VISCOTWIN SCREW PUMPS	1
1.1 Safety Notes	1
1.2 Working Principle	3
1.3 General Overview	4
1.4 Options	5
1.4.1 Options for 3A or EHEDG	5
1.4.2 Pump Face Options	6
1.4.3 Pump Housing Options	8
1.4.4 Elastomer Options	10
1.4.5 Spindle Options	11
1.4.6 Mechanical Seal Options	12
1.4.7 Bearing Housing Options	14
1.4.8 Motor Options	16
1.4.9 Frame Options	17
1.4.10 Coupling Options	18
1.5 Pump Sizing Software	19
2. INSTALLATION	21
2.1 Unpacking	21
2.2 Inspection / Technical Documentation	21
2.3 Hoisting and Transportation	22
2.4 Installation	24
2.5 Piping Before and After the Pump	25
2.5.1 Upstream Piping	25
2.5.2 Downstream Piping	26
2.5.3 Piping Before and After the Pump	26
2.6 Mechanical Seal Connection	27
2.7 Pre-Installation of Seal Water for Dual Acting Mechanical Seal	28
2.8 Electrical Installation	29
3. OPERATION	31
3.1 Pump Startup	31
3.2 Soft Starting the Pump	31
3.3 Avoiding Pump Cavitation	32
3.4 Pumping Sensitive Products	32

3.5 Material Selection for Sealing Surfaces	33
3.6 Pumping Product with Large Particulates	33
3.7 High Pressure Systems	33
3.8 CIP / COP Solution	34
3.9 Visual Inspection	35
3.10 Available Elastomer Options	35
3.11 Leakage	36
3.12 Scratches in the Pump Housing	37
4. MAINTENANCE	39
4.1 Maintenance Preparation	39
4.1.1 General Movie: HOW THE PUMP WORKS	39
4.1.2 Introduction to Web Page	39
4.1.3 Risk Assessment for Pump Maintenance	40
4.1.4 Safety Measures	40
4.2 Explaining Maintenance Levels	41
4.2.1 Maintenance Level 1 (ML-1)	41
4.2.2 Maintenance Level 2 (ML-2)	42
4.2.3 Maintenance Level 3 (ML-3)	43
4.3 Material at hand, Required Parts & Tools	44
4.3.1 Recommended Spare Parts	44
4.3.2 Recommended Tools	45
4.3.3 Recommended Oils, Grease	45
4.4 Maintenance Instructions for ML-2	46
4.4.1 Removing the Pump Housing	46
4.4.2 Complete Pump Disassembly	49
4.4.3 Complete Pump Assembly	55
4.5 Preventative Maintenance Program	61
4.5.1 First Oil Change	61
4.5.2 Oil Change Intervals	61
4.5.3 Checking Levels on Motor Gearbox Oil	61
4.5.4 Greasing Motor Bearings	61
4.5.5 Check Condition of O-rings	62
4.5.6 Check the Exterior Lip Seals and O-rings on the Mechanical Seals	62
4.5.7 Check Oil Shaft Sealing Rings	63
4.5.8 Proper Gapping of Pump	64
4.5.9 Changing Product Flow Direction	68
4.6 Failures	69
4.6.1 Foreign Material enters Pump Housing	69

5. TOOL-BOX	73
5.1 Tools	73
5.1.1 ViscoTwin Tools	73
5.1.2 General Tools	77
5.2 Spare Parts	83
5.2.1 Spare Parts for Pump Housing	83
5.2.2 Spare Parts for Seal Housing	88
5.2.3 Spare Parts for Bearing Housing	91
5.2.4 Spare Parts for Gear Housing	97
5.2.5 Spare Parts for Drive Train	104
5.3 Explosion Drawings	107
5.4 Torque Tables	108
5.5 Pump Housing Configuration	109
5.6 Oils, Grease & Lubrication Recommended	117
5.7 Oil Testing Kit (with Form)	119
6. GEEK'S CORNER	120
6.1 Oil Cooler with Oil Filter	120
6.2 Vibration Sensor with Oil Temperature Sensors	121
6.3 Quench Design for Recirculating Fluids in Mechanical Seals	122
6.4 Maximizing Bearing Lifespan	123
6.5 Equipment Commissioning Protocol	133

This page intentionally left blank.

1. ABOUT VISCOTWIN SCREW PUMPS

1.1 Safety Notes

This manual contains instructions which should be heeded to ensure personal safety and prevent damage to property. These instructions are highlighted by a warning triangle and a color to indicate the degree of the hazard. The following warnings should be observed throughout the life cycle of the pump:



ROTATING PARTS

Indicates rotating parts that can cause injury. Only perform work on or near these parts when it is locked to prevent rotation. It is advised to have a protective barrier surrounding the rotating part to prevent injury or property damage during operation.



HIGH VOLTAGE

Indicates high voltage and risk of shock or severe burns. No work should be performed around high voltage parts unless they have been disconnected from the main power supply. Any work on high voltage parts must only be performed by an electrician licensed in the state where operations and maintenance is being performed.



CRUSHING PARTS

Indicates moving parts that can crush and cut. Perform work with awareness of how parts move and where these crushing parts can be encountered.



SUSPENDED LOAD

Indicates a suspended or overhung load, where parts can fall, slip, or tip over if not properly secured. Do no work on any part that is suspended and avoid being directly under or near a suspended load. Do not stand between a stationary object and a suspended load.



LIFTING OBJECTS

Indicates heavy objects that can cause muscle strain or back injury. Lifting aids and proper lifting techniques should be used to prevent injury.



LEAKAGES

Indicates that leaks are possible. Leaked fluid can cause slip-and-fall hazards and should be cleaned up and disposed of immediately.



HOT SURFACE

Indicates a surface is hot to the touch and can cause burn injury. Do not maintain or touch a hot surface until the pump is turned off and allowed to cool. If immediate repair is necessary, it is advised to wear protective gloves while handling a hot part.



NOTE!

CAUTION

When operating the **ViscoTwin 104 G10**, it is essential to wear appropriate protective equipment.

Commissioning and operating the **ViscoTwin 104 G10** may only be performed by qualified personnel. Qualified personnel in terms of the safety instructions in this operating and safety manual are persons who have completely read this manual.

Furthermore, maintenance can only be performed by qualified maintenance technicians. Qualified maintenance technicians in terms of the maintenance instructions in this operating and safety manual are persons who have read Chapter 4 "Maintenance" and have been trained by **PROCESSTEC** in the use and maintenance of this pump. In lieu of in-person training by **Processtec** personnel, a qualified maintenance technician may also review the online maintenance movies available at <http://processtec.com>. **WARNING: ANY MAINTENANCE LEVEL 2 PERFORMED ON THIS PUMP BY UNTRAINED PERSONNEL WITHOUT THE EXPRESS WRITTEN CONSENT OF PROCESSTEC WILL RELEASE PROCESSTEC OF ANY LIABILITY AND VOID ANY WARRANTY CLAIMS ON THE PUMP..**

In addition to this operating manual, general on-site regulations as well as city, state, and federal regulations applicable to accident prevention must be made available and followed.

The **ViscoTwin 104 G10** may only be used in the applications as specified in Chapter 3 "Operation" on page 31, and only in connection with the spare parts recommended by **PROCESSTEC, Inc.**

1.2 Working Principle

Screw pumps are rotary positive displacement pumps for conveying low to high viscosity media. The **ViscoTwin G10** is a positive displacement pump characterized by a double screw, or spindle, design. The pump utilizes very close tolerances to create a series of “sealed” chambers between spindle windings. This allows the pump to more efficiently transport highly viscous product with minimal slippage and precision flowrate control as well as gentle handling of solid particulates already mixed into the product. The precision craftsmanship of the **ViscoTwin G10** means it can generate a very high pressure differential, even with a low inlet pressure.

The pump is also highly customizable, with several sizes and inlet/outlet variations to suit the needs of the product and the space available. Additionally, the pump is maintenance friendly and fully CIP-able, to ensure ease of use.

ViscoTwin G10 pumps used in the food and beverage industry are designed to meet the most stringent sanitary design criteria (3A, EHEDG), and are built with corrosion-resistant materials in accordance with recommendations from US Food and Drug Administration (FDA) and other international food safety governing bodies. Pumps are delivered with a motor, lantern, and framing as standard for easy installation.

1.3 General Overview

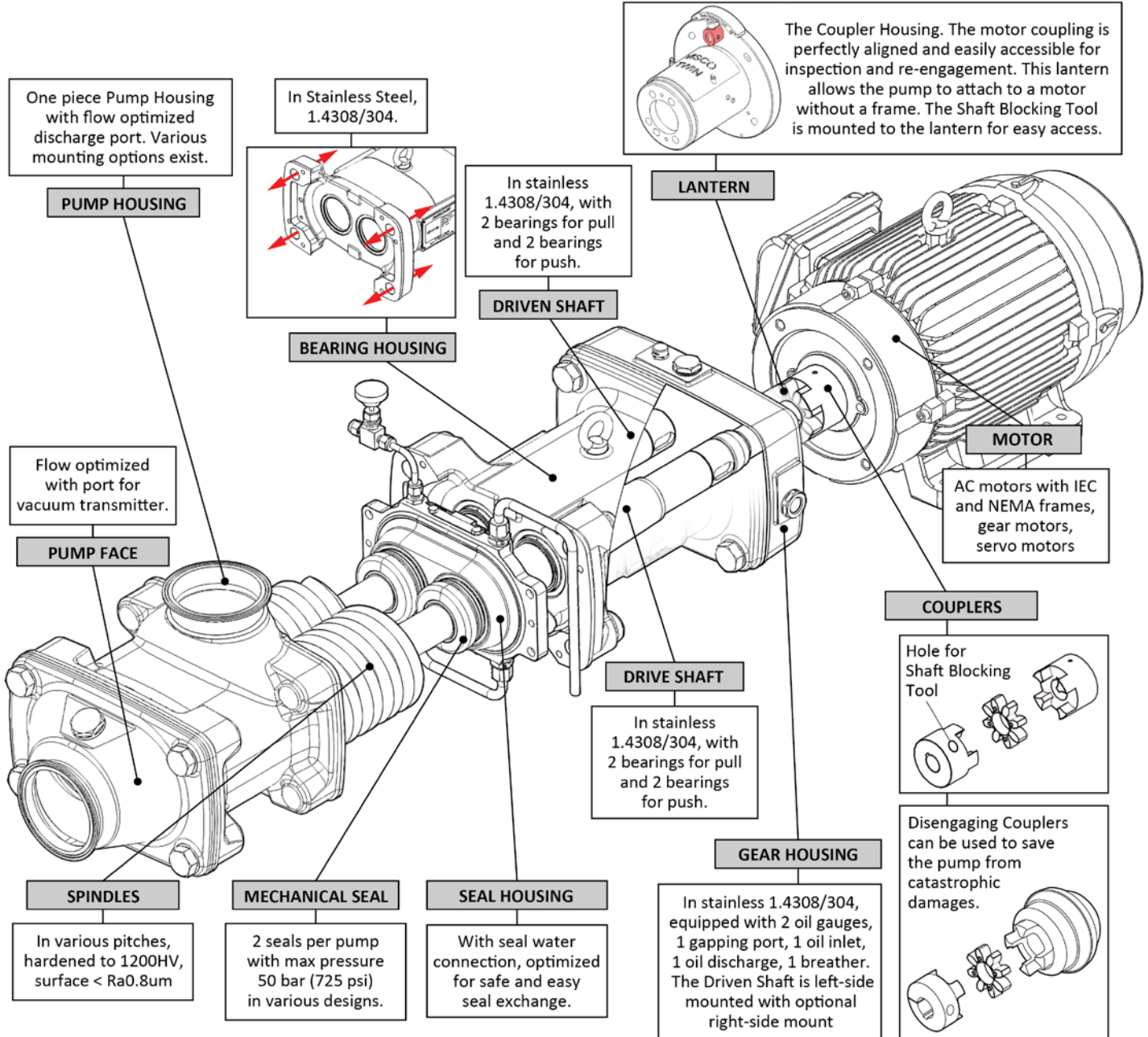

1.4 Options

1.4.1 Options for 3A or EHEDG

All **ViscoTwin** pump models including all associated options as listed throughout this Section 1.4 are designed according 3A and EHEDG guidelines. General design and detail design considerations like radii, O-ring grooves, surface treatment, material, and elastomer selection fulfill both norms.

Only pumps for the US dairy industry require the 3A symbol attached to it. The only difference is a slight improvement on the spindle polish. In case the spindles are hardened with the kolsterization process, the spindles show a matte surface, because the spindle polishing took place before the kolsterization process.

The general build of all **ViscoTwin** pumps also fulfill OSHA guidelines.

1.4.2 Pump Face Options



Processtec is always on the lookout for new ways to innovate products in our Industry, and so we are proud to announce the **NPSH Optimized Pump Face**. It was designed to transition pumped product more efficiently and gently between the pump face and the pump housing. This design helps in many ways: it keeps the product whole and intact, it eliminates cavitation, and gives the customer more options for piping configurations.

The **NPSH Optimized Pump Face** is designed to increase the efficiency of the pump face during either suction or discharge. During suction, the product has to transition from the cross-sectional area of a 4" OD tube (or smaller) to a cross-sectional area of the pump housing. By the mass flow rate equation and Bernoulli's equation, respectively:

$$\dot{m} = \rho VA = \text{constant} \qquad P_1 + \frac{\rho}{2} V_1^2 = P_2 + \frac{\rho}{2} V_2^2$$

The above equations imply that: $P_1 * V_1 = P_2 * V_2$

That is, that as the product goes from the smaller inlet to the larger pump housing, the velocity decreases thus the pressure increases. This increased pressure results in a higher NPSHa, thus increasing the pump's capabilities. The **NPSH Optimized Pump Face** also comes with a G1" sanitary port to add a pressure sensor to see the process in action.

Another factor considered in the NPSH design is smooth flow transition. Sudden changes in diameter rapidly increase the Reynolds number of the flow, which can create turbulent flow that will both decrease the pump efficiency and could damage sensitive product. The NPSH pump face addresses these concerns by using a diverging nozzle to expand the flow evenly, avoiding sharp corners and sudden changes to the flow characteristics.



The **Dual Port Pump Face** uses the same principle as the NPSH pump face. This configuration allows for two lines to conjoin at the pump which reduces piping system complexity, while maintaining the efficiency of the NPSH standard pump face.

Both the **NPSH Optimized** and **Dual Port Pump Faces** are standardized on 4"OD and a Tri-Clamp connection. Several other size options and process connection options also exist.

PUMP FACE SIZE OPTIONS		
ViscoTwin 70 2.5" / 3" DN65 / DN80	ViscoTwin 104 3" / 4" DN80 / DN100	ViscoTwin 130 4" / 6" DN100 / DN150

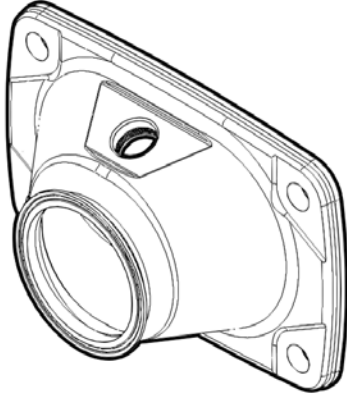
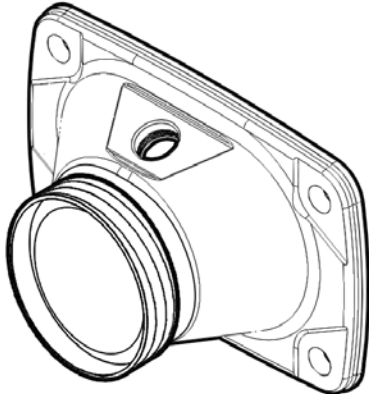
PROCESS CONNECTION OPTIONS	
 <p>Tri Clamp (Standard)</p>	 <p>Dairy Thread (DIN 11851)</p>

1.4.3 Pump Housing Options

The most common setup for **ViscoTwin** pumps is configuration FHI1A(T) (see page 112).

FH = Face In / Housing Out

I = Shafts Turning Inwards

1 = Pin Position 1

A = Spindle Arrangement "A"

T = Discharge to Top

Flow Direction

The **ViscoTwin G10** has two general flow directions: Face in -> Housing out (FH) and Housing in -> Face out (HF)

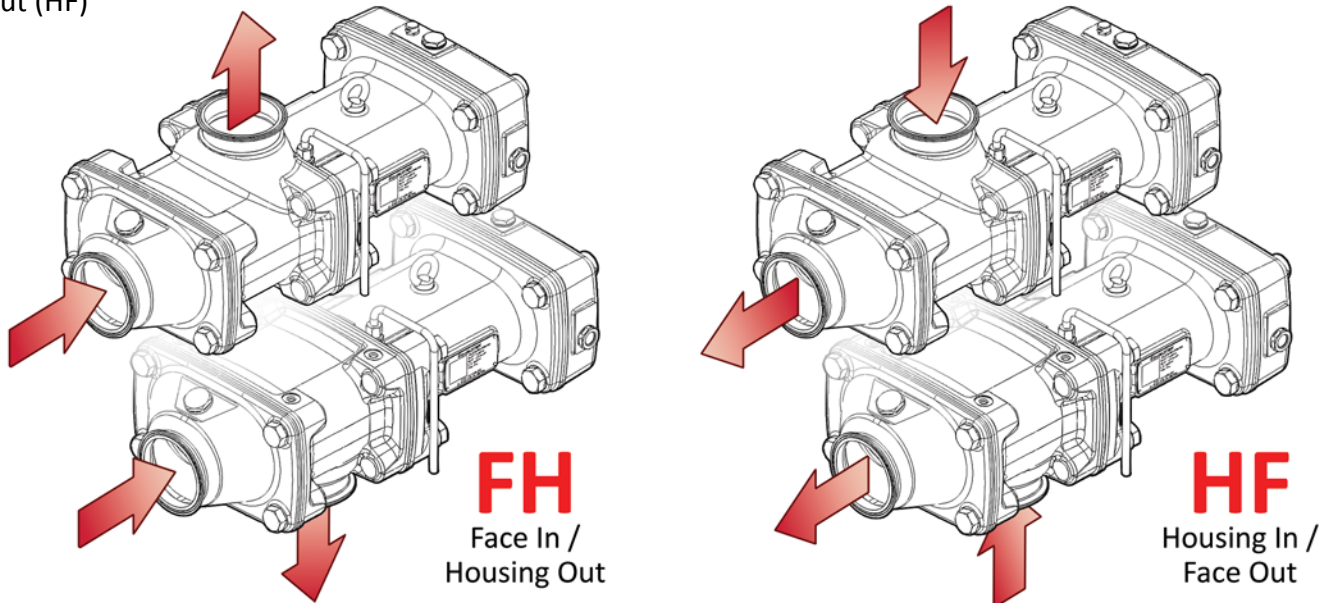

It is preferred to drag the product along the bottom of the housing which requires the shafts to spin "outwards".

Spindle arrangement for shafts turning "Inwards":

Inwards turning shafts require the PIN arrangement "1"

Housing arrangement "FH" -> Spindle arrangement "A"

Housing arrangement "HF" -> Spindle arrangement "V"

Spindle arrangement for shafts turning "Outwards":

Outwards turning shafts require the PIN arrangement "3"

Housing arrangement "FH" -> Spindle arrangement "V"

Housing arrangement "HF" -> Spindle arrangement "A"

Port Direction

The ViscoTwin G10 has two general port directions: Discharge to Top, and Discharge to Bottom.

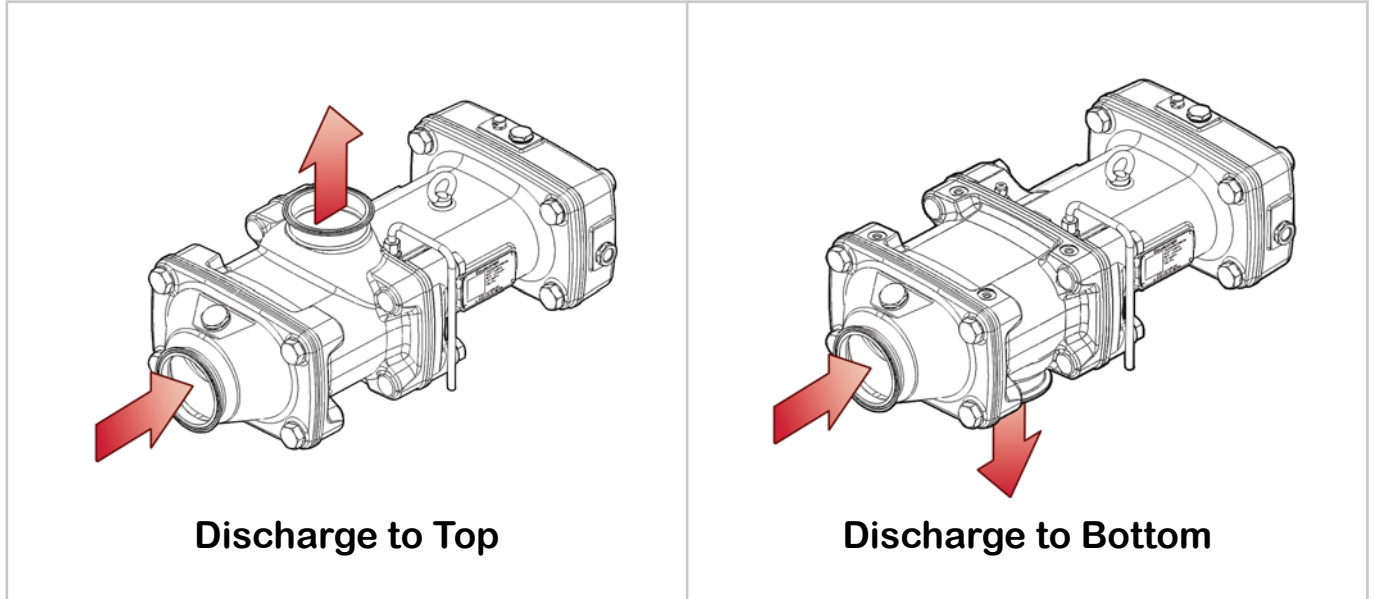

1.4.4 Elastomer Options

Elastomer Selection Table

	MAX. TEMP	MAX. FAT	TEMP / STRESS
EPDM	140° C	10%	28 bar
FKM	120° C	100%	28 bar
V70SW	200° C	100%	50 bar
PERLAST	200° C	100%	50 bar

1.4.5 Spindle Options

Three different spindle pitches are available for each **ViscoTwin** pump size. Each individual spindle is hardened to 1200 HV with a surface finish of Ra < 0.8 µm.

Smaller spindle pitches are used to create high discharge pressure. Lower spindle pitches result in less volume/revolution. High discharge pressures are easier to reach with increasing viscosity.

For product with specific particulate sizes, the spindle pitch will determine the minimum pump size. For example, if the particulate requires a cross section of 1", then the pump would need to be a Model 104.53 or Model 130.65.

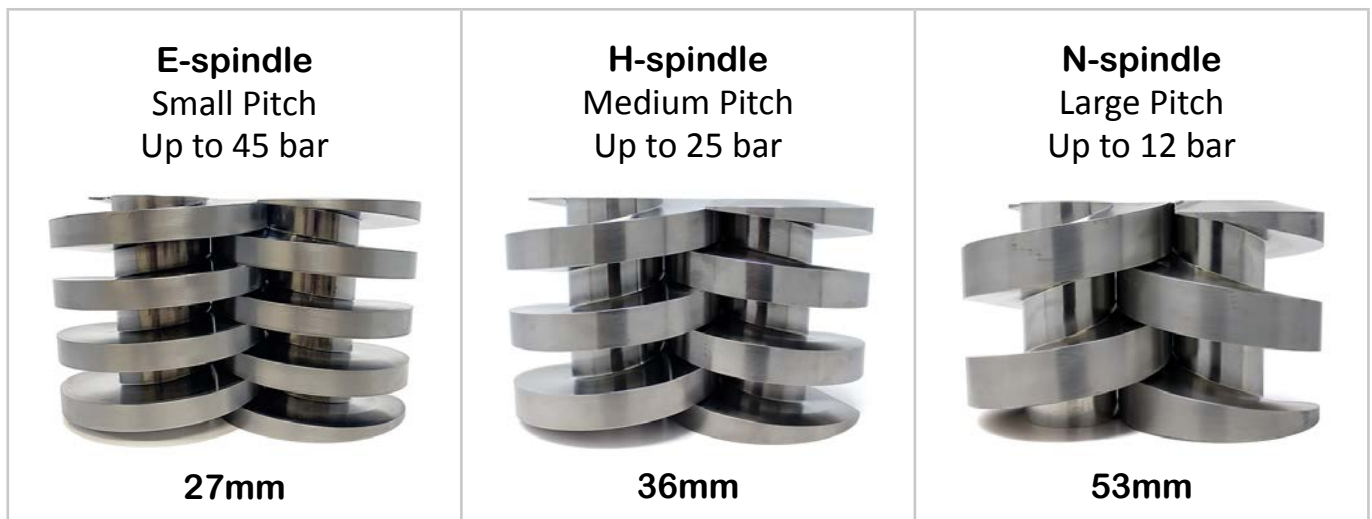

Volume per Revolution

SIZE	SCREW PITCH	VOLUME PER REVOLUTION		PARTICULATE SIZE	
		METRIC	US STANDARD	METRIC	US STANDARD
ViscoTwin 104 G10	27 mm	0.163 Liter	0.043 Gal	13.5 mm	1/2"
	36 mm	0.217 Liter	0.057 Gal	18.0 mm	11/16"
	53 mm	0.320 Liter	0.085 Gal	26.5 mm	1"

Max Pump Head RPM: 3600 rpm.

1.4.6 Mechanical Seal Options

Different mechanical sealing surfaces and elastomers are available for the **ViscoTwin G10** pumps. Material and design are selected based on application.

For easy handling, the **ViscoTwin 104 G10** is designed to use a fully pre-assembled cartridge seal to prevent assembly errors and damages to the sealing surfaces.

For a long service life, please follow the operating conditions the mechanical seals are designed for. **Processtec** has mechanical seals for various pressure and temperature requirements available.

Design Options

Mechanical seals for the **ViscoTwin** are categorized as follows:

- Single Acting Mechanical Seals (SAMS HUHNSSEAL)
- Double Acting Mechanical Seals (DAMS HUHNSSEAL)

Available sealing surfaces in the product area:

- Silicon Carbide (SIC)
- Tungsten Carbide knife edge (TC)

Available Elastomers in the product area:

- FKM (standard)
- EPDM for high temperature without fat content
- FFKM (special applications for high temperature, fat content, and stress)

The mechanical seals are designed to withstand a product area pressure of up to 400 psi. High pressure seals can be used when the product area pressure can reach up to 630 psi, however, these seals can only be used in a specially designed **HPHT** (High Pressure, High Temperature) **ViscoTwin**. Please contact **PROCESSTEC** for more information on our High-Pressure pumps.



Single Acting Mechanical Seals (SAMS)

ViscoTwin G10 Pumps with single acting mechanical seals CANNOT run dry. Due to the self draining capability of ViscoTwin G10 pumps, PROCESSTEC does not recommend using single acting mechanical seals for standard applications.



Sealing Surface:
Silicon Carbide (SiC)

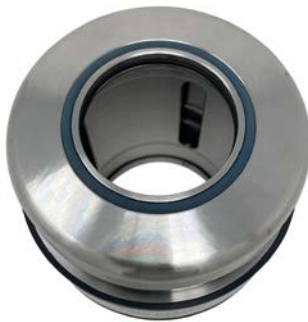

Double Acting Mechanical Seals (DAMS)

ViscoTwin G10 pumps with double acting mechanical seals can run dry as long as the quench media flows through the seal. The quench media lubricates and cools the sealing surfaces whether there is product in the pump or not.

The quench area is located between the inboard sealing surfaces (product area) and the outboard sealing surfaces (atmosphere). The quench media reduces friction between the rotating sealing surface and the static sealing surface. The quench media, in most cases, is city water, single pass. It can be glycerine or vegetable oil recirculated from a quench tank.



Sealing Surface:
Tungsten Carbide knife edge (TC)

1.4.7 Bearing Housing Options

Housing Options

The **ViscoTwin** Bearing Housing and Gear Housing have both been re-designed and offer these advantages.

Pump Head Fully in Stainless Steel

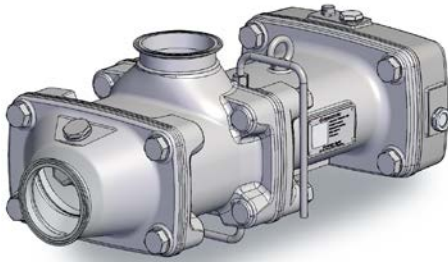

All G10 bearing housings are in **Stainless Steel**.

The **Stainless Steel** bearing housing will not show rust internally, or external wear even after many years in operation, and fulfills the highest sanitary standards.

Gear Housing / Drive Shaft LEFT

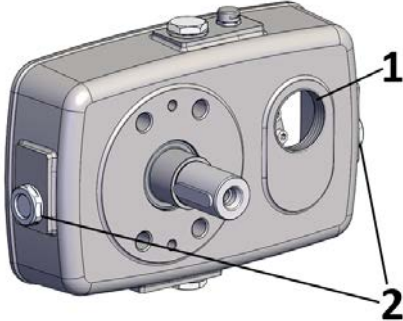

The **Stainless Steel** Gear Housing includes:

1) The Gapping Port, which allows for:

- A mounting space for a vibration sensor & oil temperature sensor to continuously monitor pump performance.
- Easy oil sampling for gear oil quality testing (see page 121).
- Spindle gapping without needing to remove and replace the gear oil.

Gear Housing / Drive Shaft RIGHT

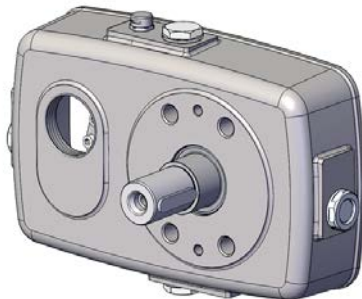

2) A second Oil Sight Gauge, which allows for:

- Oil level inspection from either side of the pump.
- Easier gear oil visual inspection (particulates in the oil, discoloration, etc.)

3) The Gear Housing is available in two arrangements:

- Drive Shaft Left (Standard)
- Drive Shaft Right (Available Option)

Bearing Options

The **ViscoTwin** pump bearing housing is designed to address various forces impacting the pump shafts, which are dependent on flow direction and discharge pressure.

Each shaft is supported by 4 angular ball bearings and one set needle bearing. The needle bearings support the shaft against radial forces in the front. The 4 angular ball bearings support the shaft against axial and radial forces in the back.

The axial forces limit the bearing's lifespan based on $P = F / A$, where:

P = differential pressure

F = Axial Force on the Shaft

A = Spindle Surface

For more details, please consult Section 6.4 "Maximizing Bearing Lifespan" on page 123.

ViscoTwin bearing housings are configured based on pressure rating and flow direction as follows:

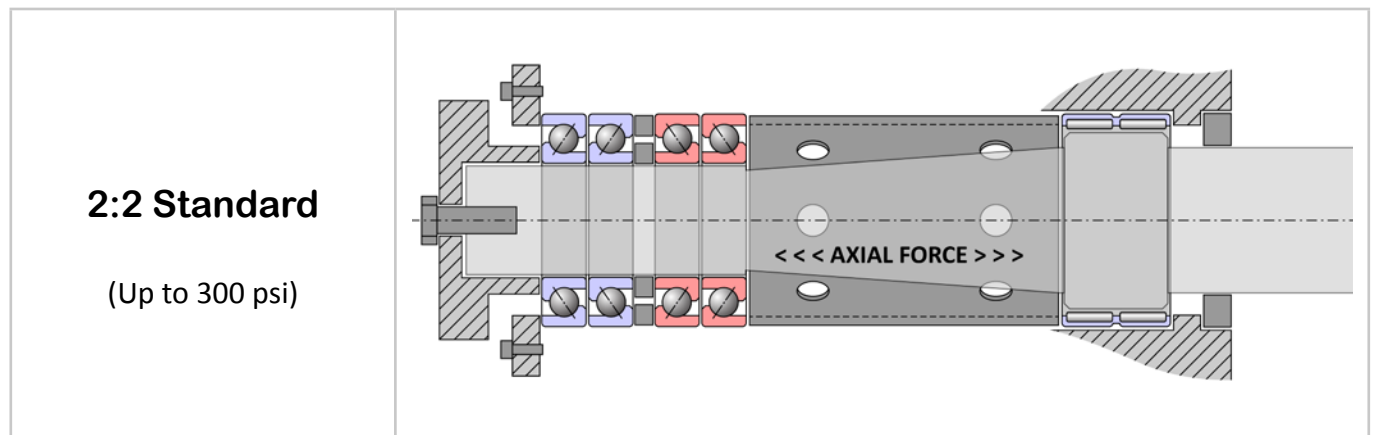

1.4.8 Motor Options

For **ViscoTwin** pump motors are optimized to deliver max torque in the 300 - 1200 rpm range at the lowest performance requirement to save cost & complexity. Above 1200 rpms, the **ViscoTwin** pump motor can be used to boost CIP & water, as low viscous media doesn't require high torque. In order to use the motor at higher rpm's, the VFD must be set to allow spin over 60 Hz. Most modern motors from reputable manufacturers can handle the 4000 rpm's, as the shaft & bearings from 4-pole + motors are typically the same as their 2-pole counterparts.

Sample with 7.5kW (10hp) Motor

DESCRIPTION	SPEED @ 50Hz	TORQUE @ 50Hz	SPEED @ 60Hz	TORQUE @ 60Hz
2-Pole Motor	2900 rpm	25 Nm/18 lb-ft	3500 rpm	20 Nm/15 lb-ft
4-Pole Motor	1450 rpm	49 Nm/36 lb-ft	1750 rpm	41 Nm/30 lb-ft
6-Pole Motor	965 rpm	74 Nm/55 lb-ft	1166 rpm	61 Nm/45 lb-ft
8-Pole Motor	725 rpm	99 Nm/73 lb-ft	875 rpm	82 Nm/60 lb-ft

Gearmotors

Gearmotors are selected when higher torque is needed at lower power & CIP boosting isn't required.

The general limit on gearboxes for overspeeding is 1.5x to 2x to nominal speed.

The generic rule of thumb is:

Metric: $(Kw \times 9549) = RPM \times Torque \text{ in Nm}$

Imperial: $(HP \times 5252) = RPM \times Torque \text{ in lb-ft.}$

The torque value of an electric motor is approximately flat between 30 Hz to 60 Hz. Above 60 Hz, the formulas above apply. Below 30 Hz, the loss in torque is very minimal.

1.4.9 Frame Options

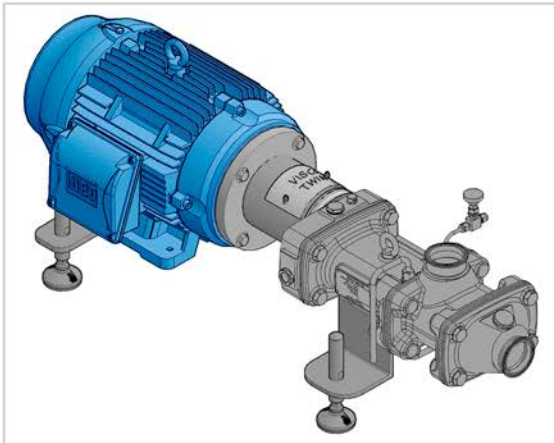

Frame #1 Frameless (w/Four Legs)

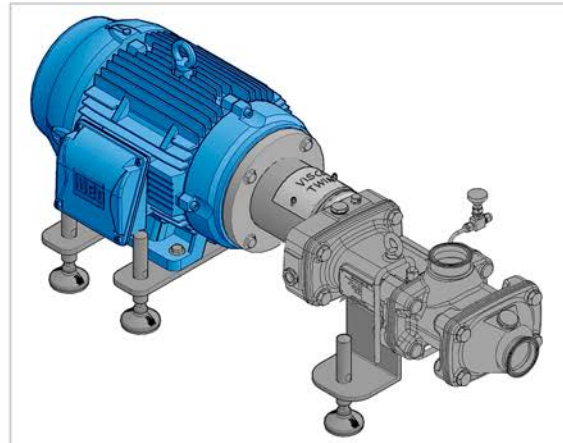

Frame #2 Frameless (w/Six Legs)

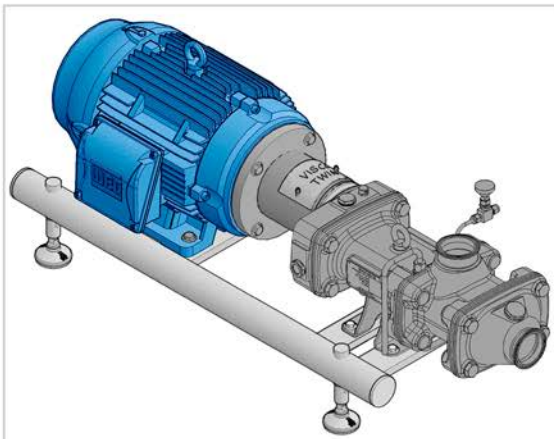

Frame #3 Heavy Duty Frame

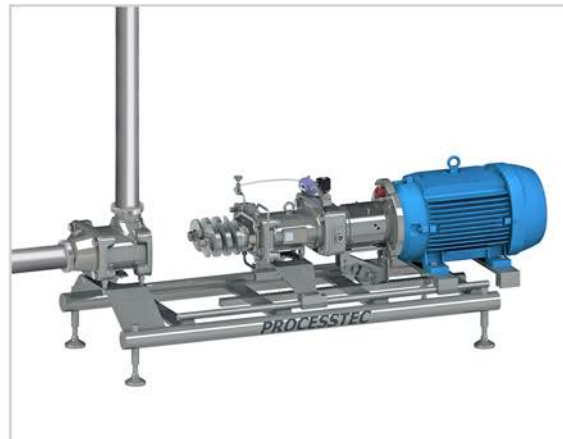

Frame #4 Service Rail

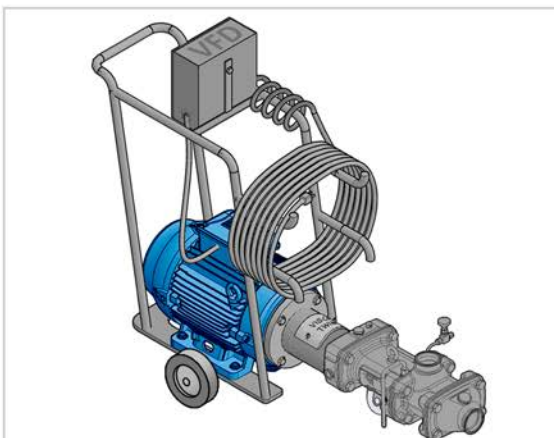

Frame #5 Caster Mount



Frame #6 On Wheels

1.4.10 Coupling Options

ViscoTwin G10 pumps feature Aluminum Claw Couplers as a Standard Option.

Also offered is a Disengaging Coupler upgrade, which automatically disengages the Motor Shaft from the Pump Drive Shaft in the event of blockage in the Spindle Area. This simple mechanism can prevent catastrophic damage to the pump in the case when spindle blockage occurs.

NOTE: When the Disengaging Coupler is disengaged due to blockage in the spindle area, it is important to stop the Motor within 1 minute to prevent the Disengaging Couplers inner bearing from overheating.



**Claw Coupler
(Standard)**



**Disengaging Coupler
(Optional Upgrade)**

1.5 Pump Sizing Software

The **ViscoTwin** pump sizing is dependent on the following factors:

- Viscosity of the pumped media
- Required Flowrate
- Required differential pressure

In the food industry it is very common to have several different set points for various products with various viscosities. Also, the pump is often used for self propelling CIP and needs to speed up in order to meet the desired CIP flowrate of 1.8 m/sec (5 ft/sec) for appropriate line cleaning.

The pump sizing is best accomplished with our proprietary sizing software. For the engineer without access to a sizing program, we created software that is ready to use.

The Pump Sizing Software can be used online from the **Processtec** website:

<https://processtec-web-c6b984f7bca1.herokuapp.com>



To use the Sizing Program, click on the Blue 'HELP ?' button and follow the detailed instructions.

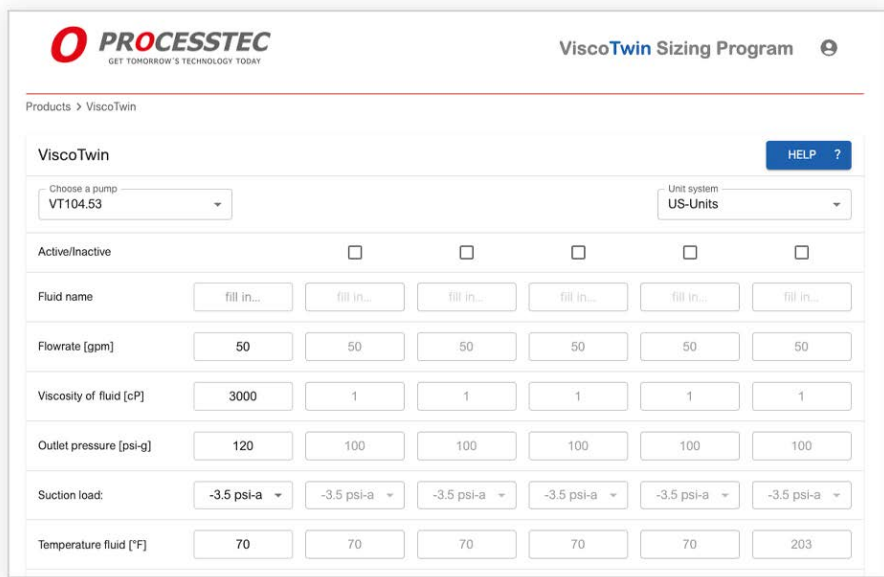

This page intentionally left blank.

2. INSTALLATION

2.1 Unpacking

Check the contents and all wrapping when unpacking the pump. Inspect the pump carefully for any damage that may have occurred during shipping. Immediately report any damage to the carrier. Keep the protective caps over the pump inlet and outlet in place until the pump is installed.

2.2 Inspection / Technical Documentation

Inspect the pump for visible shipping damages on pump head, lantern with coupling, motor, and frame. Locate the technical documentation that is shipped with the pump including:

- 0. Equipment Receiving Protocol
- 00. Pump Shipping Documents Template

- 1. Configuration Key
- 2. Equipment Commissioning Protocol

- 3.1 3.1 Pump Housing Photo
- 3.2 3.2 Spindle Photo
- 3.3 3.3 Bearing Housing Photo

- 4. Spindle and Pin Configuration
- 5. **ViscoTwin** Manual (104 G10)
- 6. Spare Parts Catalog (104 G10)
- 7. Customer Recommended Tools Catalog

Use these documents to ensure the pump is shipped as ordered & store these documents for future reference. All pumps are labeled with a sticker showing a QR code, the pump model, a serial number, and a Component ID identifying the building plan of the pump at **PROCESSTEC**.

2.3 Hoisting and Transportation

EYEBOLT INSTALLATION

The Eyebolt (Pos. 1001a) can be attached to the Bearing Housing, and is designed to allow the **ViscoTwin** Pump Head to be lifted while maintaining a center of balance.

Be sure that the Eyebolt, hooks, and all lifting straps are properly secured in place on the Pump Housing before proceeding.



STRAP PLACEMENT FOR HOISTING THE MOTOR WITH A FORKLIFT LIFTING HOIST

Forklift forks with a Forklift Lifting Hoist can also be used for lifting the **ViscoTwin** Motor off of the Frame once detached, in conjunction with a hoisting strap.

Make sure that the **ViscoTwin** Motor is completely supported and that the Forklift Lifting Hoist is firmly secured to both forks before lifting.



PUMP ASSEMBLY HOISTED IN MID-AIR

When the **ViscoTwin** Assembly is hoisted in midair via the Eyebolt, it may be necessary to counter balance the load by hand, depending on which parts are attached or detached.

The entire pump by itself should be in balance, unless the lantern and/or motor are attached, in which case you would want a second hoist on the Eyebolt of the Motor, or a lifting strap wrapped around the Lantern Body to stabilize the pump.



2.4 Installation

The following points need to be considered while installing the pump in the system:

1. All pump frames are delivered with height adjustable feet to accommodate sloped floors for drainage. The pump should always be level for proper lubrication of all the bearings. To level the pump, adjust the height-adjustable feet individually (see red arrows) until the pump is level.

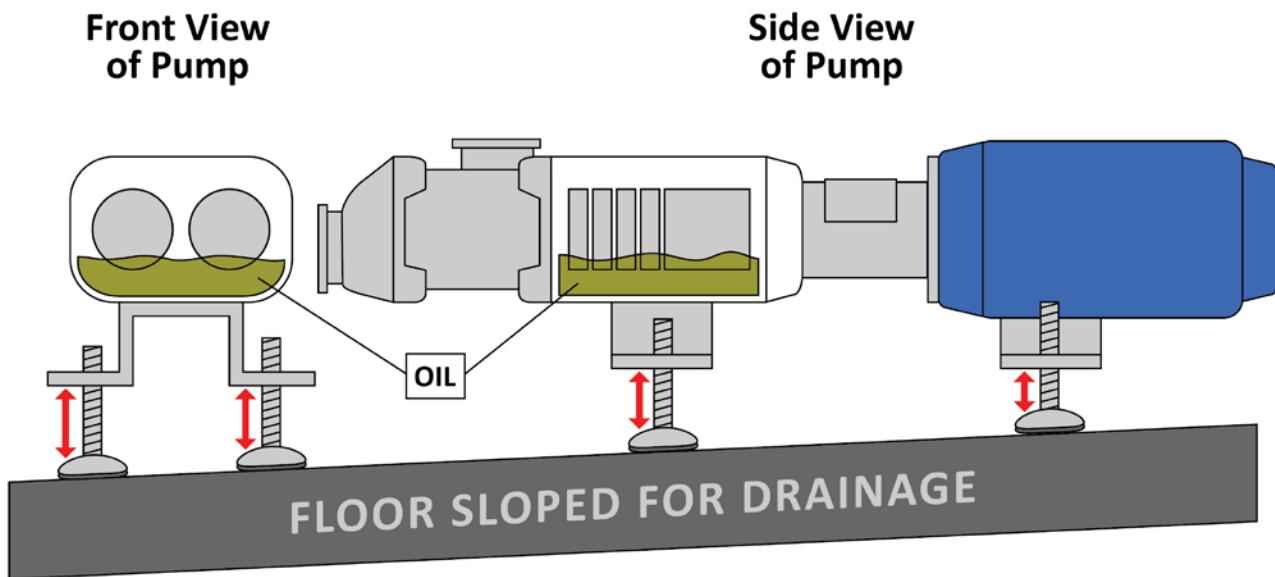

2. No excess forces should be exerted on the pump from piping systems, platforms etc.
3. Ensure good access to the oil sight glass at the gear housing for regular inspection from operators and maintenance personnel.
4. Ensure good access to the bolts (Pos. 1016) to easily remove the Pump Housing with a extended torque wrench for sanitary inspection.
5. Ensure that the whole pump can be easily accessed for preventive pump maintenance at the Pump Housing and the Gear Housing for oil change. If this can not be arranged, ensure that the pump can be easily removed from the operating location with a palette jack, forklift or rollers, into a location that allows accessing all parts of the pump.
6. Connect the Seal Water if the pump is equipped with a double seal that requires seal water. It is recommended that the seal water automatically starts and stops with the pump to save water.
7. Ensure that the electric wiring can easily be disconnected for maintenance and is not a safety hazard or dirt trap.

2.5 Piping Before and After the Pump

Sizing the correct upstream and downstream piping including valves and fittings is very involved and depends on the experience of the application engineer. **PROCESSTEC** developed a sizing program that accounts for kV values of common sanitary valves and pipe fittings at various sizes and port arrangements. The program requires the input of a valid apparent viscosity value. Please consult **PROCESSTEC** engineering if you need support to verify your piping arrangement.



2.5.1 Upstream Piping

The upstream piping of the pump requires the utmost attention. The NPSH available from the system (NPSHa) needs to be higher (higher absolute pressure) than the NPSH required (NPSHr) by the pump (lower absolute pressure).

The NPSHa must be less than the NPSHr or cavitation occurs. The pumped media creates vaporized bubble that immediately collapse & damage both the product & the pump.

The **ViscoTwin** has excellent suction capabilities and will maintain it throughout its life cycle if operated per design. Since **ViscoTwin** pumps can be used with very viscous media, any flow restrictions preventing the product from arriving at the pump suction nozzle at the desired flowrate must be removed. If the pump is sped up faster than the product can enter the pump, the pump cavitates, and will damage the pumped media, and the pump itself.

Typical installation errors that create cavitation:

- Product has a higher apparent viscosity than anticipated. Typically, colder product results in a higher apparent viscosity.
- The upstream pipe is undersized in diameter as well as the associated valves, fittings, elbows, and tees.
- Too many restricting devices in the suction line like valves, tees, elbows, or other pipe restrictions.
- The suction pipe is too long.
- Particulates in the product are caught in valves, restricting the flow

2.5.2 Downstream Piping

The max discharge pressure on standard **ViscoTwin** models depends on the pump configuration and the pumped media. Pump configurations with the largest possible spindle pitch max out between 12 bar and 14 bar. Pumps equipped with the smaller spindle pitches (consult the options table) have a max discharge pressure of 25 bar (362 psi). The max temperature with standard elastomers is 130° C (266° F).

If the desired discharge pressure can not be met with the **ViscoTwin 104 G10** due to spindle pitch restriction, the next larger pump model with a smaller spindle pitch needs to be selected.

For higher discharge pressures and temperatures, please consult **PROCESSTEC** Engineering to customize a durable pump setup for pressures up to 45 bar (692 psi) and 200° C (390° F). In Chapter 6 "Geek's Corner" in this manual (see page 120), we detail options for pressures, temperatures, and other demanding applications. Our customized pumps are engineered for the longevity of the bearings, elastomers, mechanical seals, and spindles. We can calculate the expected bearing life with optimized configurations for temperatures up to 180° C.

2.5.3 Piping Before and After the Pump

The **ViscoTwin** pump operates like a hybrid pump between a centrifugal pump and an absolute positive displacement pump, primarily due to slip between the left and right hand spindles and between the spindles and the pump housing. Due to this fact bypasses are generally not needed, allowing for a deadzone-free piping arrangement. **ViscoTwin** pumps can be installed in series without a bypass if proper engineering principles are applied.

In case the pump is cleaned with an external CIP supply pump for a higher flowrate than the **ViscoTwin** is designed for, the pushing CIP solution will propel the **ViscoTwin** pump at a relatively low flow restriction, making a bypass obsolete. The pump will start to spin, even if it is not started. No damage will occur if correct engineering principles are applied.

2.6 Mechanical Seal Connection

To maximize the service life of the mechanical seals and ensure a cool and clean area behind the inboard sealing surface, **ViscoTwin** pumps are pre-piped for pass through seal water with a manual needle valve to restrict the flow at the inlet. The inlet piping is connected with a 1/4" compression fitting. The bypass piping and discharge piping is piped in 3/8" round tubing, avoiding corners for easy passage of eventual residues or debris. The recommended flowrate is 0.1 GPM.

PROCESSTEC offers options to save water usage with:

- A pneumatic or magnetic valve to start the seal water only if necessary
- A small flowmeter (1/4") to confirm the flow of seal water
- A quench tank installation (see Section 6.3 "Quench Design for Recirculating Fluids in Mechanical Seals" on page 122)

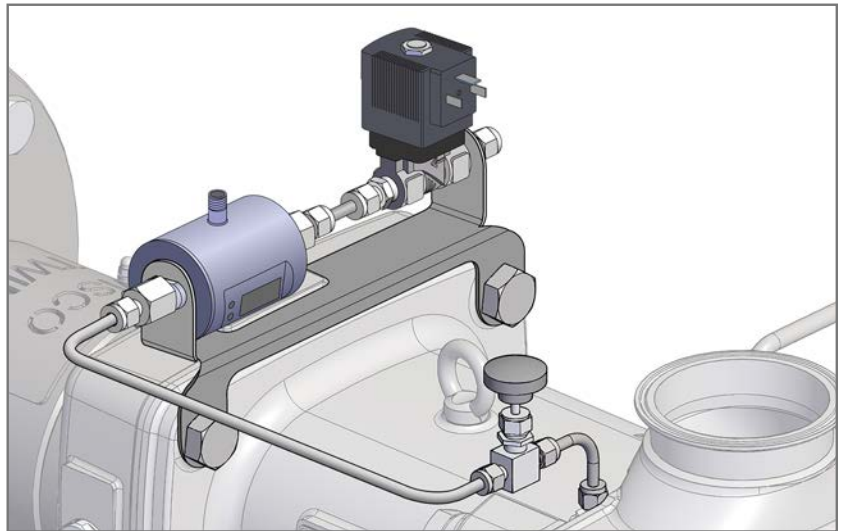

2.7 Pre-Installation of Seal Water for Dual Acting Mechanical Seal

When using city water (from the tap), it is advisable to run an in-line filter, to prevent any possible debris or sediment from entering the pump.

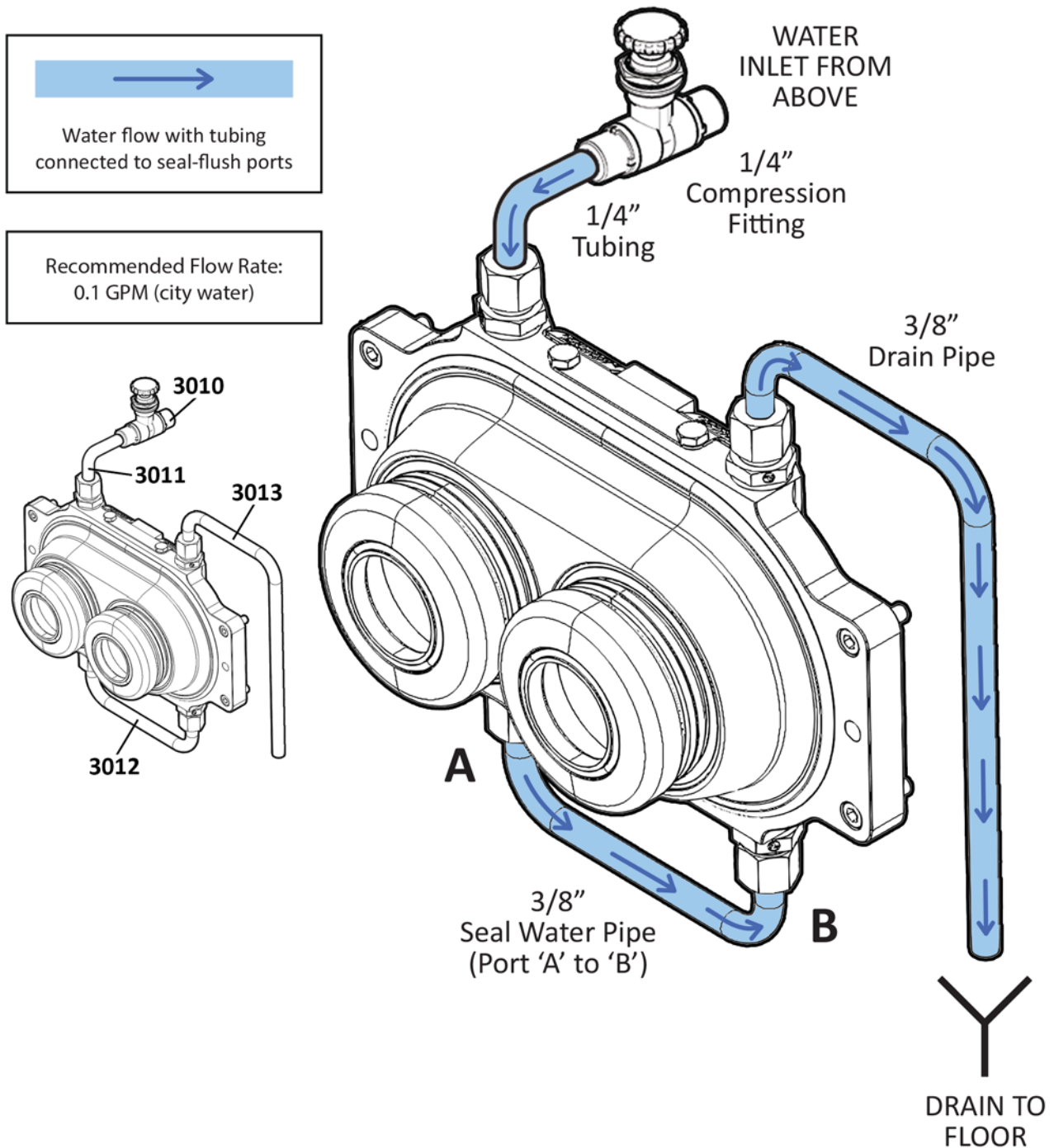

2.8 Electrical Installation

PROCESSTEC on default selects 3-phase AC motors that meet country specific installation requirements. For the US and Canada we select NEMA frame motors. For Mexico, Europe and Australia we select IEC motors that meet country spec.

Other motor standards are available upon request. It is up to the client to follow the country specific guidelines for electrical installations.

This page intentionally left blank.

3. OPERATION

3.1 Pump Startup

Before starting up the **ViscoTwin 104 G10** pump after the installation, or after system changes upstream occur, it is important that no debris or foreign material can enter the pump head. Because of the tight clearance between the spindles and the pump housing, any debris entering the pump housing can cause severe damage to pump housing and spindles. After any system modification upstream occur, the piping needs to be severely flushed. Before the pipe flushing begins, the pump suction line needs to be disconnected from the pump face or pump housing, and directed to the floor so no debris can be flushed into the pump housing.

3.2 Soft Starting the Pump

It is recommended to gradually ramp up the pump speed, as opposed to performing a hard start. Twin Screw pumps are mostly used in heavy duty applications with viscous media, often with particulates, and changing viscosity based on product properties and fluctuating temperatures. Most food products have non-Newtonian fluid behavior and are shear thinning.

When starting up slow, the viscous product is forced into motion. Friction along the pipe walls is imparted onto the product. The imparted friction on the shear thinning product lowers the apparent viscosity momentarily. The lower apparent viscosity results in a lower overall pressure drop in the system. This is especially helpful in the suction line of the pump. Lower apparent viscosity increases the NPSH available (NPSHa).

The soft start allows the pump to ramp up speed over a period of 15 to 30 seconds in a controlled manner while reading the motor amps from the VFD into the PLC. The shear thinning effect is sensed with the decreasing amps indicated by the VFD.

3.3 Avoiding Pump Cavitation

When the pump cavitates due to a flowrate that is too high for the suction line size and the product viscosity, the flowrate needs to be lowered. The NPSH Optimized Pump Face from **PROCESSTEC** has a built in pressure gauge port to install a vacuum sensor to indicate the NPSH directly at the pump head. With the feedback signal from the vacuum gauge, the pump can be safely operated at min NPSH required, resulting in its max speed for the given setup without damaging the product and pump.



3.4 Pumping Sensitive Products

Sensitive product like macaroni & cheese sauce or cooked potato pieces can easily be pumped without creating damage to it if the pump housing and the spindles are correctly sized. However, if the pump suction is too strong, sensitive product contents like macaroni can be stretched and break apart. In this case, the flowrate must be lowered as a momentary solution. For a long term solution, the pump suction system must be modified by increasing the suction line size and removing flow restrictions like valves, Tee's etc. The NPSH at the pump face should read between 2 and 4 feet, depending on product.

Note that -14.5 psi (- 1 bar) is absolute vacuum on this planet. If the suction line is undersized, hence the NPSH is too low or almost zero, no pumping system exists to provide the desired performance.

3.5 Material Selection for Sealing Surfaces

ViscoTwin pumps are often operated with viscous and sticky media in a stop and go application. The pump re-start can stress the seal faces at the engagement pins and break brittle seal face materials such as Silicon Carbide. In this case, a sustainable solution would be to use Tungsten Carbide knife edge seal faces.

3.6 Pumping Product with Large Particulates

When the application requires pumping product with large particulates, the pump housing needs to be configured accordingly:

- **Considering Spindle Size** - Large enough spindle pitches: A spindle pitch 65 means that the cross section between the flanks is 32.5mm = 1-1/4 inches.
- **Considering Port Size** - Large enough port size: The most critical opening is in the seal area towards the pump housing. Bigger is better.
- **The Ideal RPM Range** - Slow enough spindle speed: between 300 and 800 rpm.

3.7 High Pressure Systems

In case a differential pressure above 300 psi is required for extended operating times, **PROCESSTEC** offers system upgrades up to 600 psi and 375° F. This is limited to selected spindle pitches, therefore limiting max flowrate and min product viscosity.

3.8 CIP / COP Solution

CIP stands for Clean In Place, which is the process in which a pump is cleaned in its current location. It is standard for most pumps in the Industry. The **ViscoTwin** can be CIP'd in a variety of different setups:

Self-Propelled Cleaning

The pump is used as a CIP return pump. This is mostly the case when a pump is installed as a tank discharge pump.

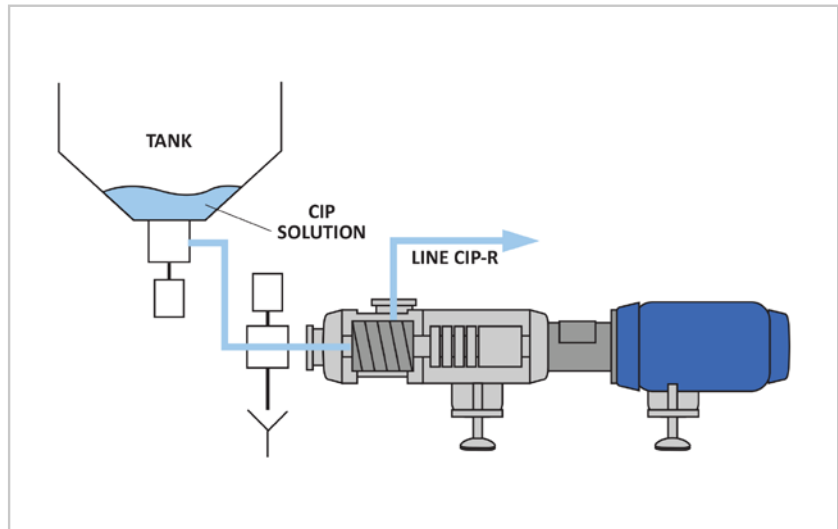

Inline Cleaning

The pump does not need to propel the CIP solution and is part of the cleaned pipe line. A dedicated CIP pump upstream is propelling the CIP solution. In this case there is no need for a bypass around the pump housing to achieve a high flow rate in the upstream and downstream pipe.

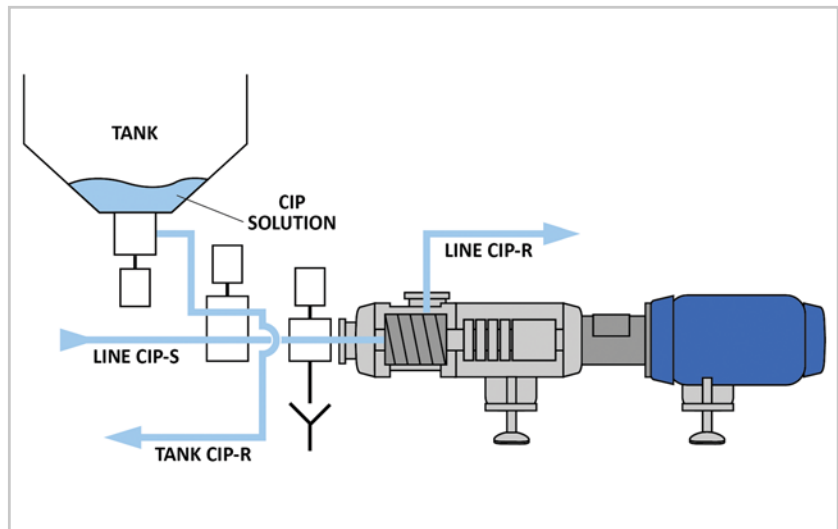

ViscoTwin pumps operating with watery solution are like a hybrid between a centrifugal and positive displacement pump.

ViscoTwin pumps have sufficient slip for CIP solution to be pushed through the pump head without creating large pressure drops. The spindles will start spinning by themselves if not operated during in-line cleaning. To protect the outboard seal faces from overheating, the seal water supply should be activated during CIP.

3.9 Visual Inspection

We recommend daily observation of the pump as described in Subsection 4.2.1 "Maintenance Level 1 (ML-1)" on page 41.

3.10 Available Elastomer Options

If excessive wear and tear on elastomers in the Pump Housing is observed, **PROCESSTEC** offers various elastomer options to address demanding applications based on temperature, oil/fat content, and permeable stress. We offer EPDM, FKM, V70SW and Perlast elastomers to address various oil content/temperature/stress combinations.

For more information, check out the Elastomer Options Chart in Subection 1.4.4 "Elastomer Options" on page 10.

3.11 Leakage

Leakage is the primary concern for mechanical sealing. Mechanical Seal Leakage depends on many factors, most of which are listed in the table below. Leakage is generally significantly higher during initial startup when the elastomers are dry and need to be broken-in to allow proper sealing. Afterwards, the elastomers should seal completely during normal operations.

Possible Causes of Mechanical Seal Failures or Leakage

FAILURES OR LEAKAGE	POSSIBLE CAUSES
Dry-Running	Thermal shock from lack of seal water
Mechanical Shock	Stator installed at the wrong angle
Wear on the sliding surfaces	Deposits on the sliding surfaces
Corrosion on the sliding surfaces or springs	Dirt, oil, or grease on the sliding surfaces
Axial misalignment	Improper installation
Extreme vibrations	Excess loads from pipe connections
Caked-on product on the product-side of the seal (DAMS)	Damaged/destroyed atmospheric-side of the seal (DAMS)
The seal faces will glue together	Long storage time and the screws have not been hand-turned as instructed

Slow leaks are a primary concern as the small amount of liquid tends to evaporate into the atmosphere. This is unacceptable with toxic or environmentally harmful liquids. The standard for such cases is a Double Acting Mechanical Seal with a quench medium to flush out and contain dangerous product media in a separate, closed system.

Due to legal regulations, leaks must be constantly monitored to protect the environment. For maintenance or cleaning cycles, it is recommended to monitor flushing loss using either a visual flow measurement or a back-pressure sensor. **PROCESSTEC** advises regularly inspecting and/or replacing the visible O-rings on the mechanical seal cartridge during maintenance and inspection intervals or repairs.

3.12 Scratches in the Pump Housing

If the spindles or the pump housing show scratches, this indicates that the spindles touch each other or touch the pump housing. The following should be investigated first:

A) Pump configuration with PIN position:

Each **ViscoTwin** Pump Housing is configured based on flow direction and kind of pumped product. The standard configuration is **FHI1A(T)**:

- F: Face In
- H: Housing Out
- I: Spindles turning inwards
- 1: Pin Position 1
- A: Spindle Arrangement "A"
- T: Discharge to Top

For more information, please see Section 5.5 "Pump Housing Configuration" on page 109.

B) The spindles are not correctly gapped. The clearances between the spindles show that the flights on one side touch each other. Please consult Subsection 4.5.8 "Proper Gapping of Pump" on page 64.

C) The spindles touch the housing at the pump face end when A) and B) are verified and correct. The clearance between spindle tip and housing is too small for the viscosity of the pumped product and the associated rpm. This issue can be addressed with tapered spindles.

This page intentionally left blank.

4. MAINTENANCE

4.1 Maintenance Preparation

4.1.1 General Movie: HOW THE PUMP WORKS



QR Code

Please use any cell phone or tablet with a QR reader application to start the movie.



This movie can be found at

<http://processtec.com/videos/ViscoTwin-Mechanics-2.mp4>

4.1.2 Introduction to Web Page

In the **ViscoTwin** Overview section on the main **PROCESSTEC** webpage (<http://processtec.com/viscotwin-pumps-overview.html>), you will find a variety of content that is helpful for pump maintenance, including links to various Maintenance Movies, General Documents and Manuals, and other useful information. Use the QR Code to the right to access this section on the **PROCESSTEC** web page.



On that Overview page, you will find the Downloads section (<https://processtec.com/viscotwin-downloads-overview.html>), which contains a directory of folders containing the following technical information:



- Explosion Drawings G10
- Manuals G10 (70, 104, 130)
- Pin Configurations G10
- Spare Parts Catalog G10
- Tool List G10
- Torque Tables G10

4.1.3 Risk Assessment for Pump Maintenance

1) Risk of Pump Falling

There are certain precautions which must be taken when working around **ViscoTwin** pumps. Failure to adhere to the proper guidelines for transporting or lifting of the pump can result in personal injury, or damage to the pump itself.

When moving or lifting the pump, please keep the following in mind:

- Pumps and related parts are heavy, and must be moved using the proper steps as outlined in Section 2.3 "Hoisting & Transportation" on page 22.
- When moving the pump, you must observe the center of gravity and also the maximum weight of the load.
- Only use suitable slings with sufficient load-bearing capacity.
- Only use proper hoisting attachment points to lift the motor.
- Never stand underneath the motor while it is being lifted or suspended.
- Never stand between the suspended load and a stationary object (such as a wall or floor)
- Keep the surrounding area clear from obstructions, and free from people

2) Metal Splinters due to Sharp Spindle Flights

This mostly occurs because the spindles touched while in operation. Reasons for touching spindles are failure to correctly install the spindles on the shaft or foreign material entered the pump and scratched the spindles and the pump housing.

3) Pinched Fingers / Cut Fingers

Pinched fingers occur when the pump is manually moved while the pump housing is removed. Carrying the pump on the spindles is risky because the spindles can turn towards each other.

4.1.4 Safety Measures

1) **LOTO** - Follow factory instructions for LOTO (Lock Out / Tag Out).

2) **Wear Gloves** - To prevent burns and cuts.

3) **Hands-On Training** - Qualified Maintenance Technicians performing **ML-2** tasks need to have hands-on training. They need to become familiar with the pump, the required tools, the supporting documents and charts.

4.2 Explaining Maintenance Levels

4.2.1 Maintenance Level 1 (ML-1)

ML-1 is the daily observation of the pump by the operator, which includes the following steps:

STEP 1) Checking for Product Leaks

A) Product leaks can occur around the pump housing due to a leaking pipe connection, or a worn and brittle O-ring in the pump housing.

B) In case the seal water is cloudy, the mechanical seal has a leak and needs to be inspected by a maintenance technician.

STEP 2) Check for Oil Leaks at the following positions:

A) Both Shaft Seal Rings in front of the Bearing Housing (Pos. 2322).

B) The Shaft Seal Ring in the back of the Gear Housing (Pos. 1010).

C) The Oil Level Sight Gauges at the Gear Housing (Pos. 2360).

D) Both Oil Plugs at the Gear Housing (Pos. 2233).

E) The Vent Plug on top of the Gear Housing (Pos. 2232)

In case the operator notices oil leaks on the floor, a maintenance technician needs to inspect the pump.

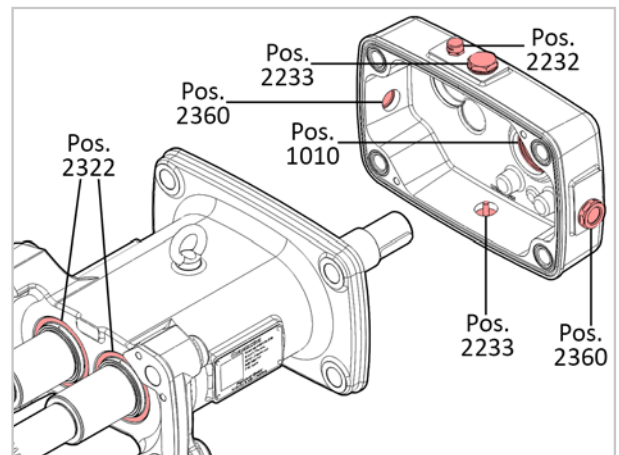

STEP 3) Check for Strange Noises

In case unusual noises occur, the pump needs to be stopped. A maintenance technician needs to inspect the pump for:

- A) Foreign material in the pump housing
- B) Damaged mechanical seals
- C) Damaged or mis-aligned motor coupling
- D) Damage at the motor, failing motor bearings

4.2.2 Maintenance Level 2 (ML-2)

ML-2 is recommended to only be performed by qualified maintenance technicians as defined in Section 1.1 "Safety Notes" on page 1.

STEP 1) Sanitary Inspection

In order to inspect the product contact area, the pump housing needs to be removed by unthreading the FOUR (4) bolts in Pos. 1016. The spindles, the mechanical seals, the seal housing and the pump housing with pump face can be inspected from every angle.

STEP 2) Oil Inspection/Sampling and/or Oil Change

A) The first oil change is required after 250 hours. This is known as the break-in period.

B) It is recommended to sample the oil every 3 months after the first oil change and exchange it accordingly with the recommended oil. Based on the humidity of the environment, the oil can degrade more or less quickly depending on amount of starts and stops the pump is exposed to. Repeated start/stopping heats and cools the bearing housing, which sucks in outside air and moisture into the gear housing.

STEP 3) Exchange Mechanical Seal

Please follow the steps outlined in Subsection 4.4.2 "Complete Pump Disassembly" on page 49.

STEP 4) Gapping the Pump

In case the spindles touch each other after a pump cleanup because foreign material entered the pump housing, the pump needs to be gapped. Please follow Subsection 4.5.8 "Proper Gapping of Pump" on page 64.

4.2.3 Maintenance Level 3 (ML-3)

ML-3 is recommended to only be performed by a specialized shop that handles bearing exchange and pump testing like **PROCESSTEC**.

STEP 1) Timing

In very rare cases the pump needs to be timed. Timing is necessary when the gearwheel space is too small for gapping. The gearwheel needs to be moved by one tooth. Timing is always necessary after a bearing exchange.

STEP 2) Bearing Fatigue

Exchange all bearings with the correct tools only by a specialized shop. For more information on Bearing Fatigue, please see Section 6.4 "Maximizing Bearing Lifespan" on page 123.

4.3 Material at hand, Required Parts & Tools

4.3.1 Recommended Spare Parts

The recommended spare parts at hand are shown in the explosion drawing in the following positions:

Pos. #	Description
2192	Pump Face O-Ring
2194	Spindle Screw O-Ring
2195	Pump Housing Alignment Pin
1088	Seal Housing O-Ring
2535	Mechanical Seal (Single Acting or Double Acting)
2322	Shaft Sealing Ring (Bearing Housing)
1010	Shaft Sealing Ring (Gear Housing)
2513	O-ring Large for Gear Housing
2514	O-rings Small for Gear Housing
2360	Oil Level Sight Gauges
2233	Magnetic Screw Plugs
2249	Coupling Spider (Rubber)

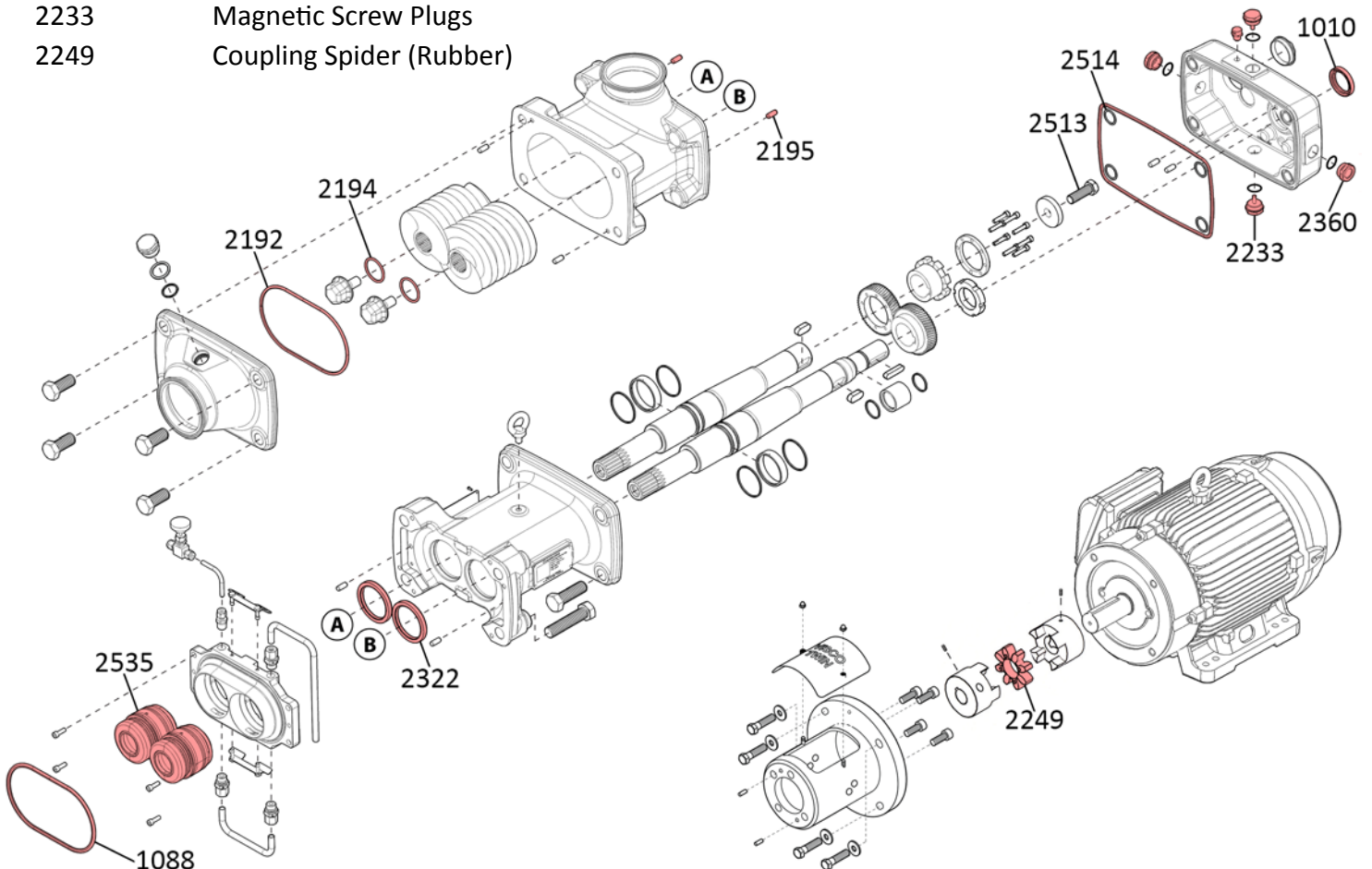

4.3.2 Recommended Tools

The recommended tools at hand are Tools for 104 ML-2 use only. (Please see Section 5.1 "Tools" on page 73 for more information)

4.3.3 Recommended Oils, Grease

The quality of the bearing oil greatly influences the service life of the pump, especially pumps operating in humid environments with many starts and stops. Please study Section 6.4 "Maximizing Bearing Lifespan" on page 123.

It is important to notice that not all oils can be mixed. Synthetic oils based on Polyglycol have water absorbing properties that greatly increase service life, but cannot be mixed with oils based on Polyalphaolifin.

PROCESSTEC recommends Klubersynth UH1-6 150 for **ViscoTwin** pumps. It's a foodgrade oil with water absorbing properties. Its viscosity covers a large temperature range. The max temperature is 140° C.

The **ViscoTwin 104 G10** requires 0.7 liter gear oil.

In cold locations like receiving bays, **PROCESSTEC** recommends the selection of the lower end viscosity, normally indicated with numbers 68 or 100. For warmer processing environments, we recommend a more viscous oil indicated with numbers 150.

For more information on Oils, please see to Section 5.6 "Oils, Grease & Lubrication Recommended" on page 117.

4.4 Maintenance Instructions for ML-2

4.4.1 Removing the Pump Housing

Removing the Pump Housing can be done for the following reasons:

- A) Sanitary Inspection
- B) First action in case the pump does not pump product.

Required Tools:

- Socket Hex Nut (30mm)
- Torque Wrench (Large) for torques up to 150 Nm

STEP 1)

Remove the FOUR (4) Hex Screws (Pos. 1016).

STEP 2)

Remove the whole Pump Housing (Pos. 2530) towards the front.

STEP 3)

Inspect the product contact surfaces for cleanliness.

STEP 4)

Inspect the product contact surfaces for scratches and bruises.

STEP 5)

Inspect the elastomers for wear and tear, and correct installation.

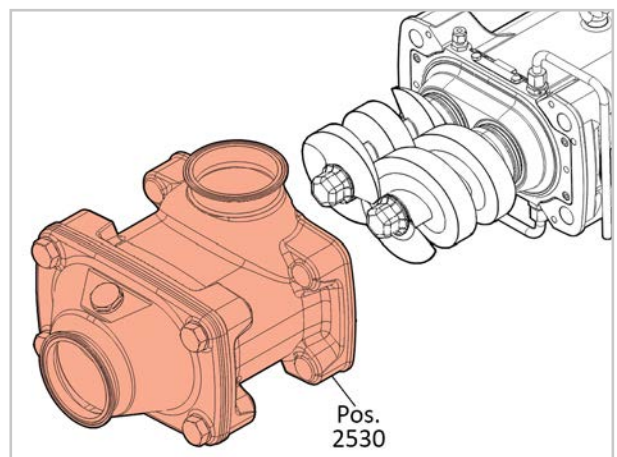
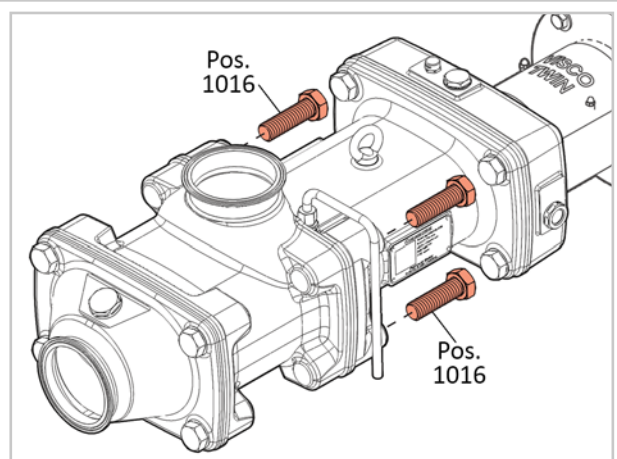

STEP 6)

Turn the Spindles with your hands (use gloves) and inspect that the spindles turn freely and do not touch.

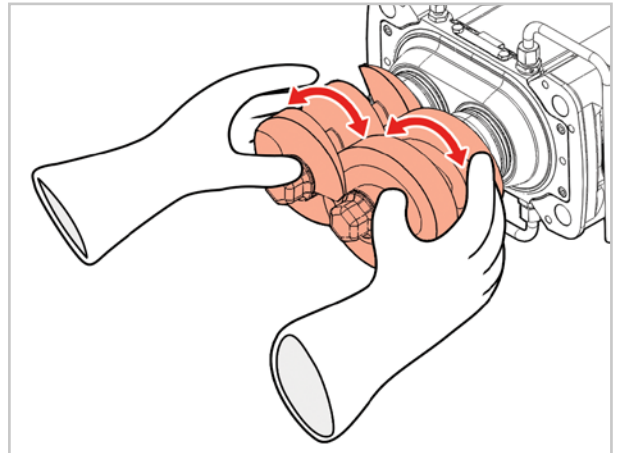

STEP 7)

Push the spindles axially to inspect that the shafts are tight, indicating that the bearings are in good condition.

STEP 8)

Hold a white sheet of paper underneath the spindles, point a flashlight from underneath and verify that the spindles do not touch.

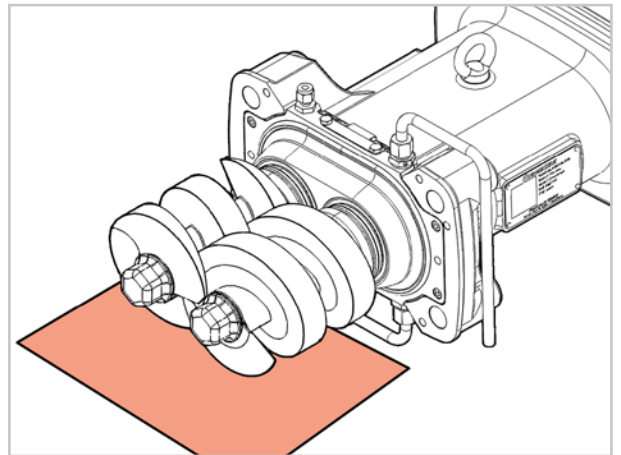

STEP 9)

In case of touching or tight gaps, the pump needs to be gapped. This can become necessary if foreign material entered the pump, blocked one of the shafts, and the gearwheel slipped. For more information, please see Subsection 4.5.8 "Proper Gapping of the Pump" on page 64.

Action Steps for Re-assembly of Pump Housing:

STEP 1)

Slide the Pump Housing (Pos. 2530) back into position. Check that the TWO (2) Pump Housing Alignment Pins (Pos. 2195) are still in place. If you removed the pins, please re-install it as required by your Pump Housing Pin Configuration (Pos 1, 2 or 3).

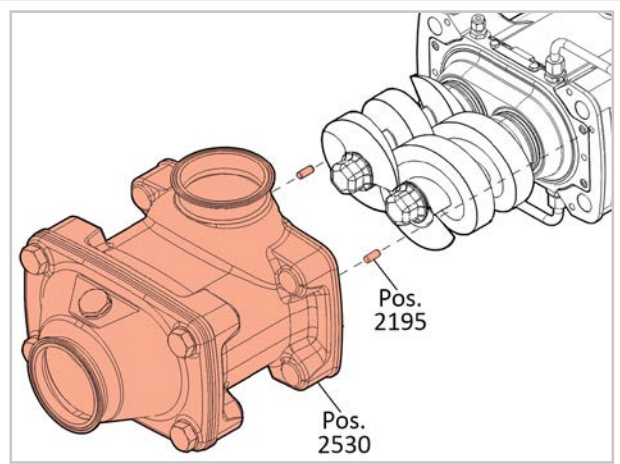

STEP 2)

Re-install the FOUR (4) Hex Screws (Pos. 1016) and torque each of them to 150 Nm.

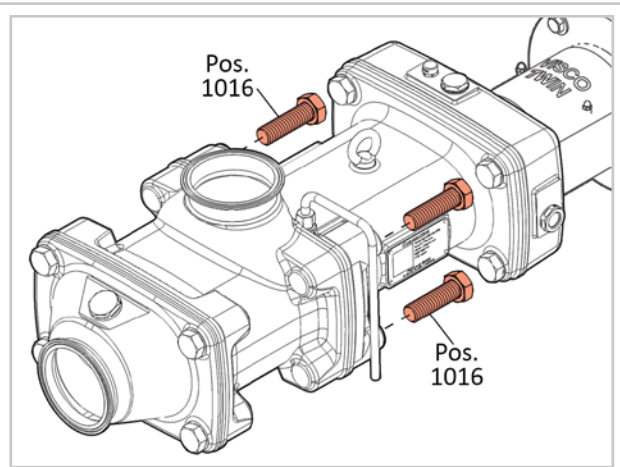

4.4.2 Complete Pump Disassembly

Removing the Pump Housing can be done for any one of the following reasons:

- A) Exchange the Mechanical seals
- B) Exchange all elastomers in the product contact surface area.
- C) Exchange the spindles because of wear or reconfiguring the pump
- D) General Pump Inspection

Required Tools:

- 8mm Hex Nut Socket (for Pos. 3002)
- 30mm Hex Nut Socket (for Pos. 1016 & 2527)
- 36mm Hex Nut Socket (for Pos. 2180)
- Torque Wrench - Small (1/4" Drive, Capable of Torque ranging from 8 to 15 Nm)
- Torque Wrench - Large (1/2" Drive, Capable of Torque up to 150 Nm)

Action steps for complete pump disassembly:

- STEP 1)** Removing the Pump Face
- STEP 2)** Removing the Pump Housing
- STEP 3)** Blocking the Shaft in the Lantern Area
- STEP 4)** Removing the Spindles
- STEP 5)** Removing both seals from the Seal Housing
- STEP 6)** Inspecting the Pump Parts

STEP 1)

REMOVING THE PUMP FACE

A. Remove the Pump Face (Pos. 2528) by unthreading the FOUR (4) Hex Head Bolts (Pos. 2527). The Pump Face (Pos. 2528) is still held in place by the Pump Face Alignment Pins (Pos. 2196). You might need a rubber mallet to remove it because it can sit very tight.

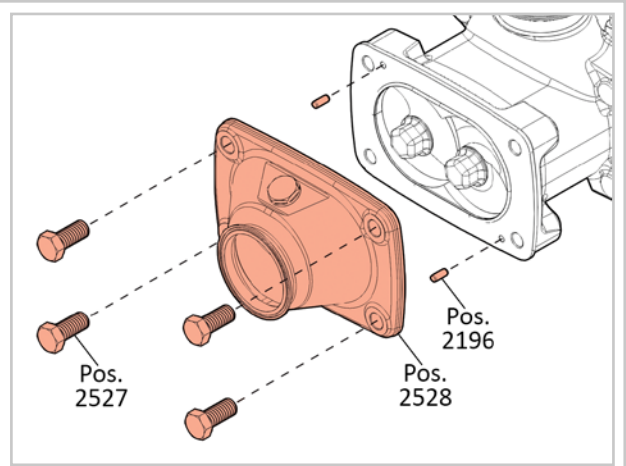

STEP 2)

REMOVING THE PUMP HOUSING

A. Remove the FOUR (4) Hex Screws (Pos. 1016) from the Pump Housing (Pos. 2530).

B. Remove the Pump Housing (Pos. 2530) from off of the Spindles (Pos. 2202).

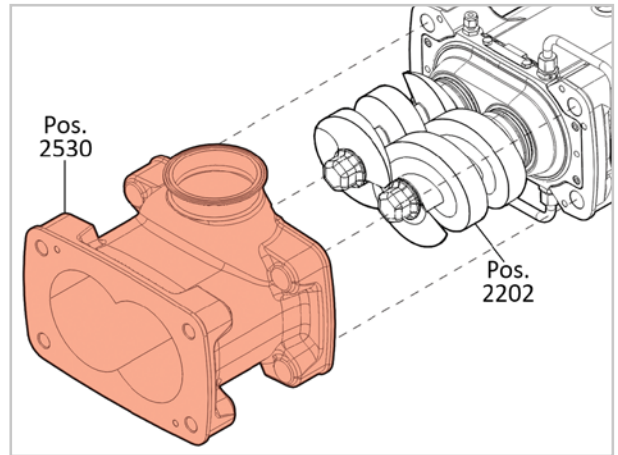
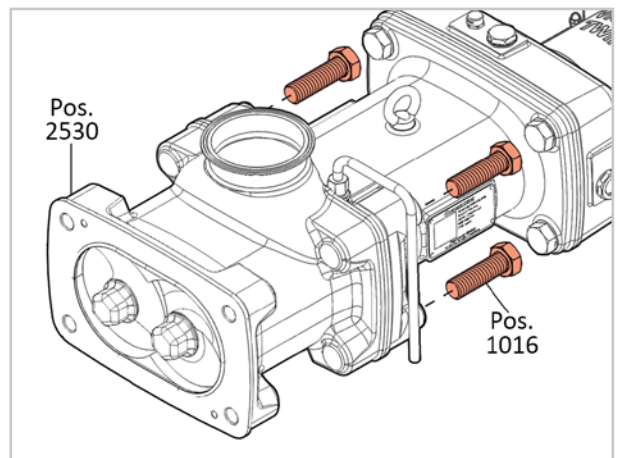

STEP 3)

BLOCKING THE SHAFT IN THE LANTERN AREA

Blocking the Shaft in the Lantern area prevents the Spindles (Pos. 2202) from turning during maintenance and inspection.

A. On the Lantern, remove both Cap Nuts (Pos. 3002) and then remove the Lantern Safety Guard (Pos. 3001).

B. Turn the Spindles (Pos. 2202) until the hole on Pump Coupler (Pos. 2247) is facing up.

C. Insert the Shaft Blocking Tool (Pos. 3036) into the Lantern opening, and guide the peg into the hole on the Pump Coupler (Pos. 2247), making certain that it is all the way in and firmly in place. Be sure that the Shaft Blocking Tool also engages both side edges of the Lantern opening.

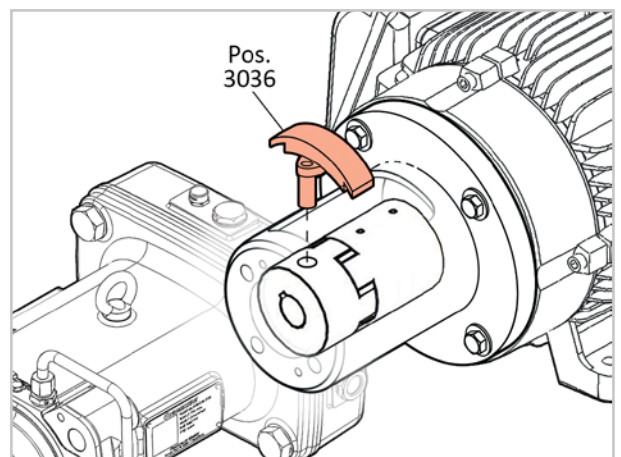
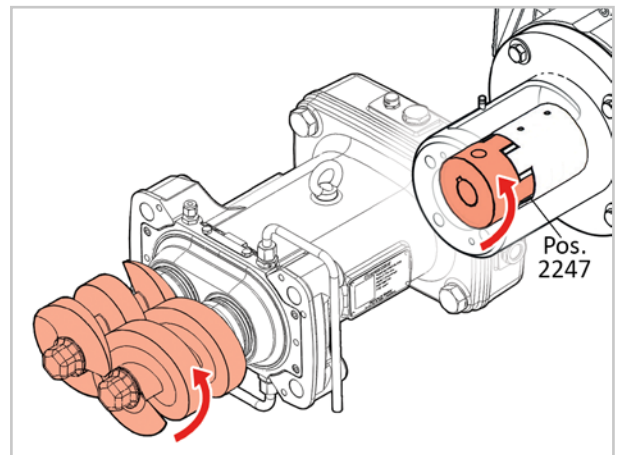
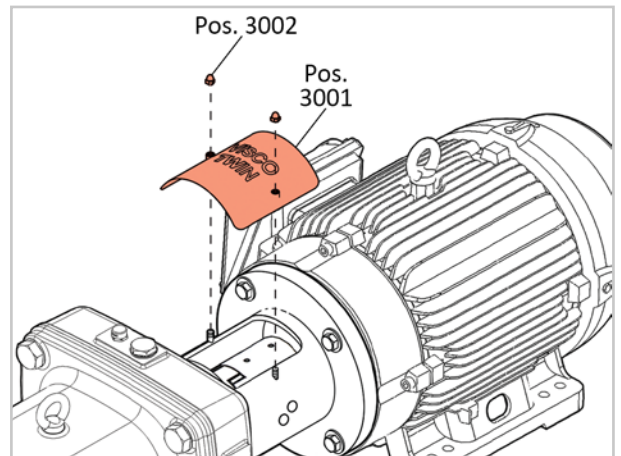

STEP 4)

REMOVING THE SPINDLES

A. Once the Shaft Blocking Tool (Pos. 3036) is in place, use the Aluminum Spindle Screws Slotted Nut on a torque wrench to remove the Spindle Screws (Pos. 2180) on the Drive Shaft (Pos. 1000) and Driven Shaft (Pos. 2171).

B. In the event that the Spindles get stuck, simply use a Rubber Mallet to knock them loose. Hit one side, then the other, alternating until driven loose.

C. WARNING! DO NOT USE A METAL HAMMER. DOING SO WILL CAUSE DAMAGE!

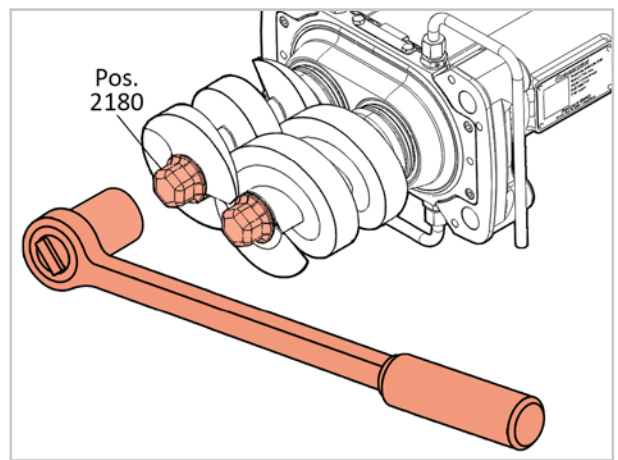

STEP 5)

REMOVING BOTH SEALS FROM THE SEAL HOUSING

A. Using the custom Seal Removal Tool from **PROCESSTEC**, attach the tool to one Mechanical Seal (Pos. 2535), and secure it with the included O-ring.

B. With a firm grip on the Mechanical Seal (Pos. 2535) with the Seal Removal Tool clamped onto it, pull the Mechanical Seal off of the Drive Shaft (Pos. 1000).

C. Repeat the same process for the other Mechanical Seal (Pos. 2535) and pull it off of the Driven Shaft (Pos. 2171).

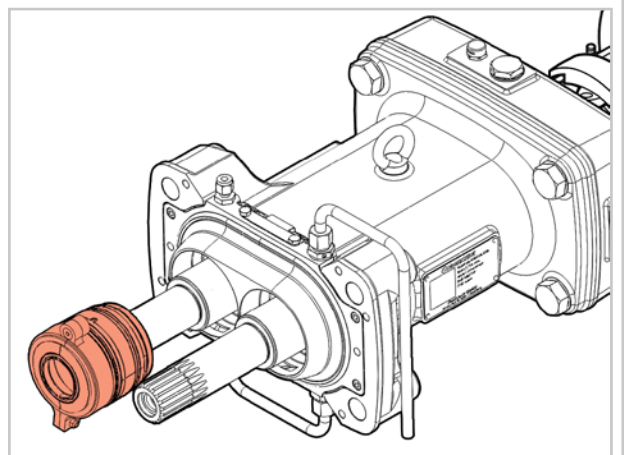
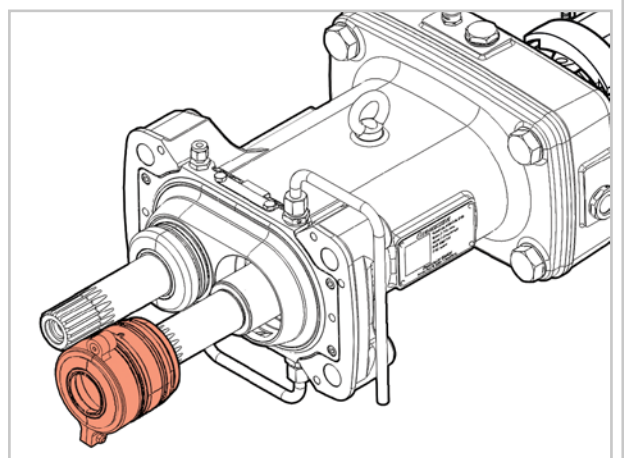
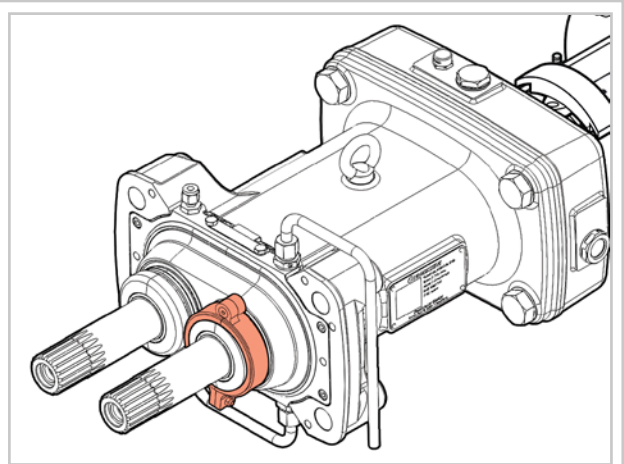

STEP 6)

INSPECTING THE PUMP PARTS

A. The Pump Housing (Pos. 2530) should be smooth inside and not show any rough spots. Both Spindles (Pos. 2202) should show smooth surfaces, not be worn from touching or show splintered corners.

B. Both the Drive Shaft (Pos. 1000) and the Driven Shaft (Pos. 2171) need to sit tight without any play or wiggle room in axial and radial direction. If any, there could be very minimal play from the gear wheels. Grip both shafts and wiggle up & down, forward & backwards, and also side to side, to check for excessive wear. If even small movements are detected, it will require a complete bearing replacement before further operation.

C. Inspect both Mechanical Seals (Pos. 2535) for visible wear and tear. In case the seals are worn, please send them to **PROCESSTEC** for refurbishing or replacement.

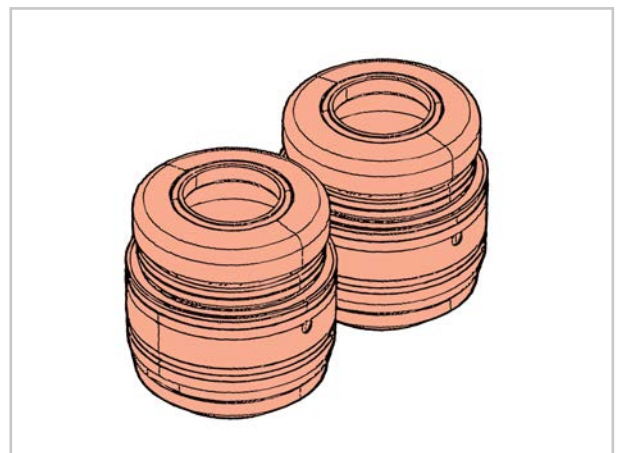
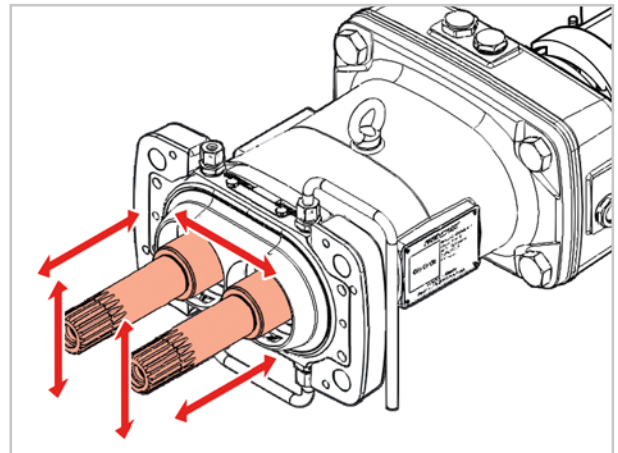
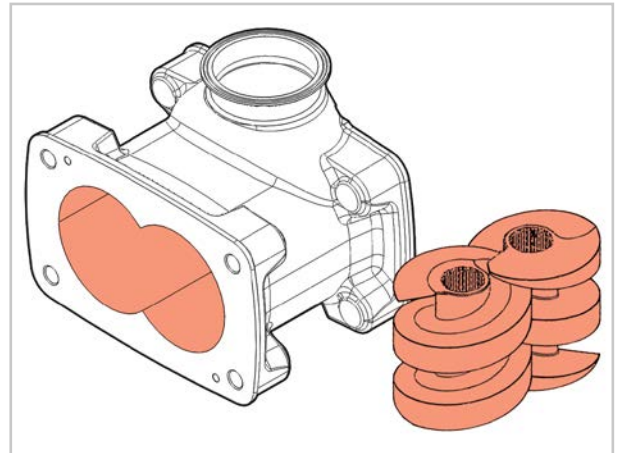

4.4.3 Complete Pump Assembly

To assemble the pump, follow each of the steps outlined in this subsection.

Required Tools:

- 8mm Hex Nut Socket (for Pos. 3002)
- 30mm Hex Nut Socket (for Pos. 1016 & 2527)
- 36mm Hex Nut Socket (for Pos. 2180)
- Torque Wrench - Small (1/4" Drive, Capable of Torque ranging from 8 to 15 Nm)
- Torque Wrench - Large (1/2" Drive, Capable of Torque up to 150 Nm)

Action steps for complete pump assembly:

- STEP 1)** Installing the Seals into the Seal Housing
- STEP 2)** Installing both Spindles
- STEP 3)** Fixating the Spindles
- STEP 4)** Removal of the Shaft Blocking Tool
- STEP 5)** Reinstall the Lantern Safety Guard
- STEP 6)** Verify that the Spindles Spin Freely
- STEP 7)** Check gapping of Spindles
- STEP 8)** Install the Pump Housing
- STEP 9)** Installing the Pump Face to the Pump Housing

STEP 1)

INSTALLING THE SEALS INTO THE SEAL HOUSING

A. Lightly lubricate all exposed elastomers at both Mechanical Seals (Pos. 2535) with the delivered silicone-based lubricant. Adding too much lubricant can be detrimental to properly seating the O-rings.

B. Using the custom Seal Removal Tool from **PROCESSTEC**, attach the tool to one of the Mechanical Seals (Pos. 2535), and secure it with the included O-ring. This tool allows for a smooth installation of the Mechanical Seal into the Seal Housing. Then you can remove the Seal Removal Tool, and use it to press in the other Mechanical Seal.

C. Install both of the Mechanical Seals (Pos. 2535), making sure that the flat spots on the seals align with the flat spots on the Seal Housing (Pos. 2188). Be sure that the Mechanical Seals (Pos. 2535) are pressed all the way into the Seal Housing (Pos. 2188), and that both are seated evenly.

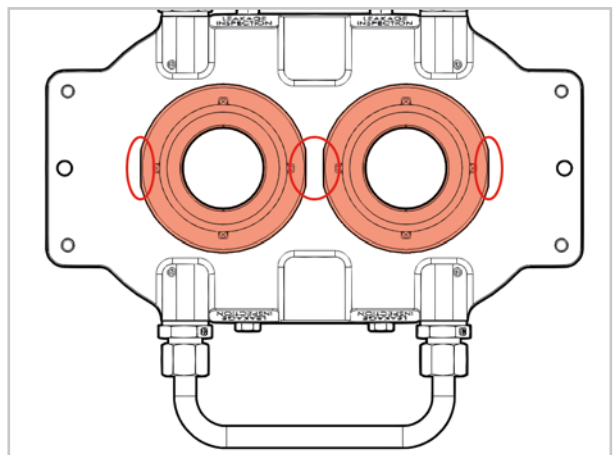
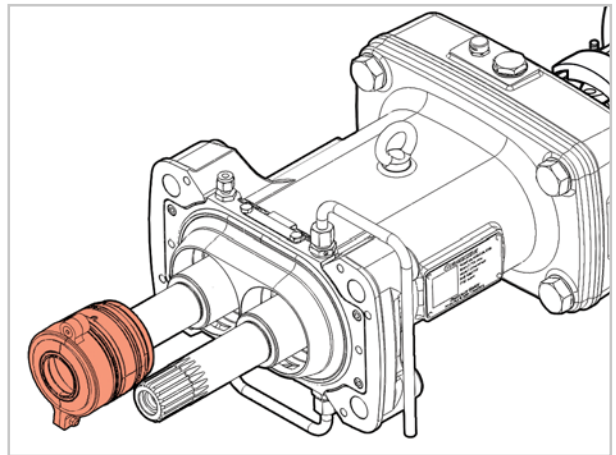
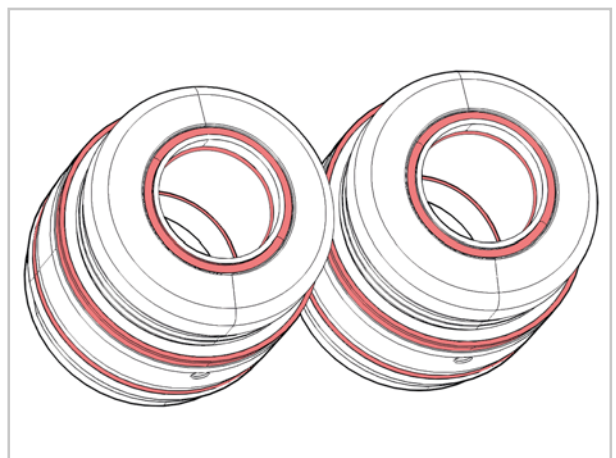

STEP 2)

INSTALLING BOTH SPINDLES

A. Determine whether you have Spindle Configuration "A" or "V", based on your Pump Housing Configuration (Please refer to Section 5.5 "Pump Housing Configuration" on page 109 for more detailed information on identifying "A" or "V" Spindle Configurations).

B. Place both Spindles (Pos. 2202) on a clean dry surface, with the spline sides facing downwards, and align them into either "A" or "V" configurations.

C. Rotate both Spindles (Pos. 2202) until they are aligned from the top view as shown to the right, where the colored/highlighted flat top surfaces of the spindles sit totally flush with each other.

D. Pick up both Spindles (Pos. 2202), taking care to keep them aligned with each other in the current position, and place them onto the shafts, rotating them very slightly inwards and outwards, until they slide onto the Drive Shaft (Pos. 1000) and Driven Shaft (Pos. 2171) splines. Before proceeding to the next step, be sure to check that the Spindles are still aligned properly. If both Spindle surfaces are still flush with each other, then you have achieved proper alignment.

E. Press the Spindles (Pos. 2202) towards the Product Side of the Bearing Housing (Pos. 1001) until they are flush up against the Seal O-Ring of the Mechanical Seals (Pos. 2535).

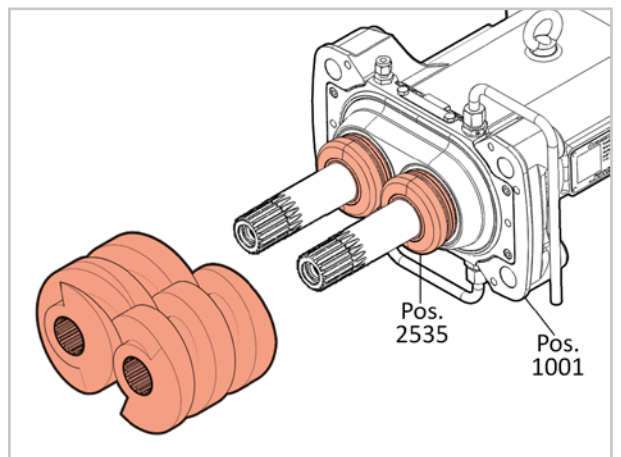
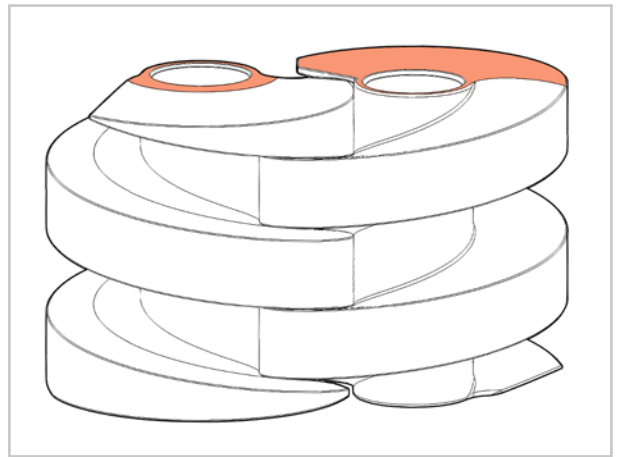
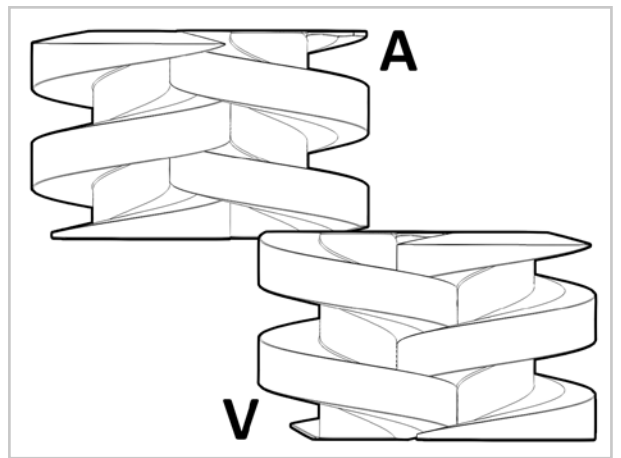

STEP 3)
FIXATING THE SPINDLES

To fixate the Spindles (Pos. 2202), use the Spindle Bolts (Pos. 2180) with O-rings (Pos. 2194). Add a small amount of Blue Loctite™ to the Spindle Screw threads to secure it. Torque both Spindle Bolts (Pos. 2180) to 150 Nm.

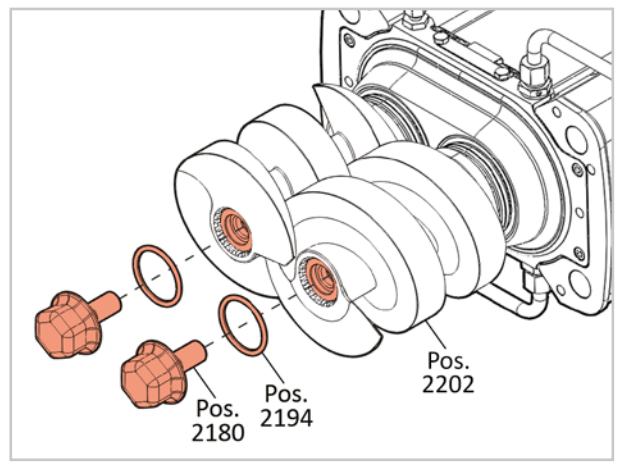

STEP 4)
REMOVAL OF THE SHAFT BLOCKING TOOL

Remove the Shaft Blocking Tool (Pos. 3036) in the Lantern area, and if available, re-secure it to the Shaft Blocking Tool Mount (Pos. 3004) on top of the Lantern (Pos. 3000).

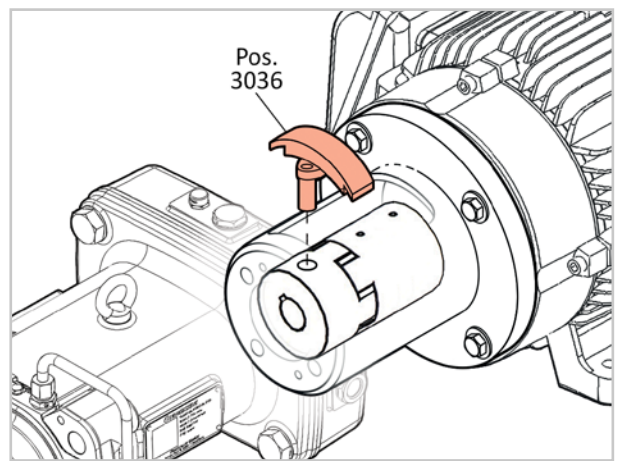

STEP 5)
REINSTALL THE LANTERN SAFETY GUARD

Re-install the Lantern Safety Guard (Pos. 3001) and secure it in place with the Cap Nuts (Pos. 3002).

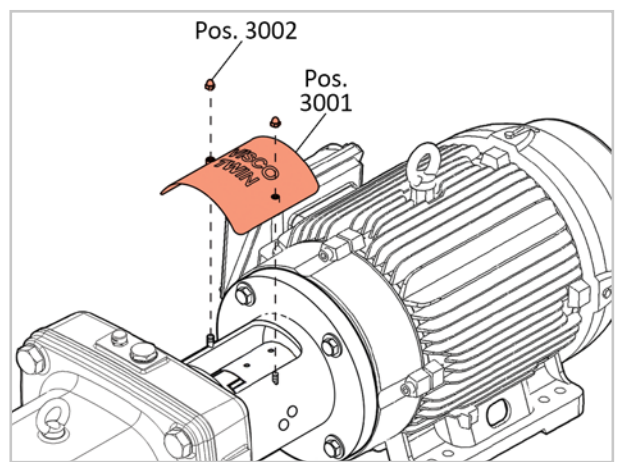

STEP 6)

VERIFY THAT THE SPINDLES SPIN FREELY

Verify while turning both Spindles (Pos. 2202) by hand that they are spinning freely. Then hold a white paper underneath the Spindles and visually check that there is an even gap between the spindle flights. The Spindles are not allowed to touch.

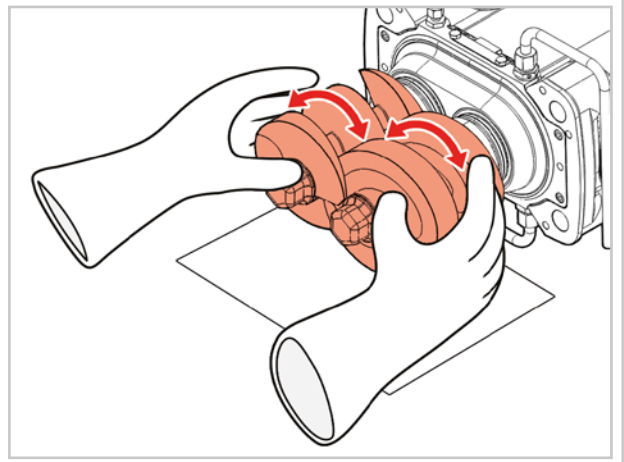

STEP 7)

CHECK GAPPING OF THE SPINDLES

In case the Spindles (Pos. 2202) touch each other, the shafts need to be gapped (See Subsection 4.5.8 "Proper Gapping of Pump" on page 64). In case that the tolerances between the flights are not equal but do not touch, gapping is not absolutely necessary.

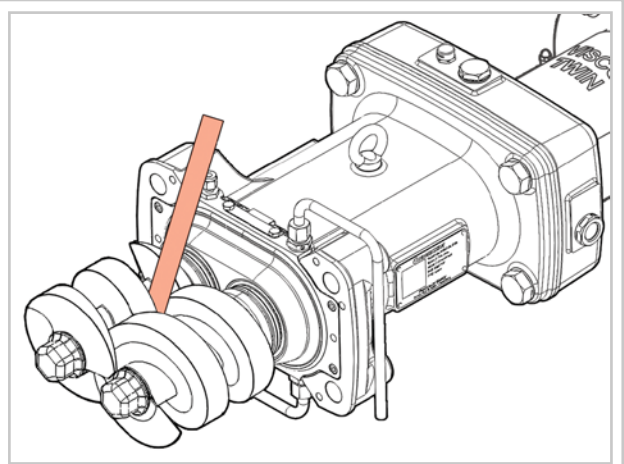

STEP 8)
INSTALLING THE PUMP HOUSING

A) Verify that the O-ring (Pos. 1088) is correctly seated and that both Alignment Pins (Pos. 2195) are installed in the proper locations based on your pump's Pin Configuration (see Section 5.5 "Pump Housing Configuration" on page 109).

B) Carefully slide the Pump Housing (Pos. 2530) onto the Spindles, and then tighten and torque all FOUR (4) Hex Screws (Pos. 1016) to 150 Nm.

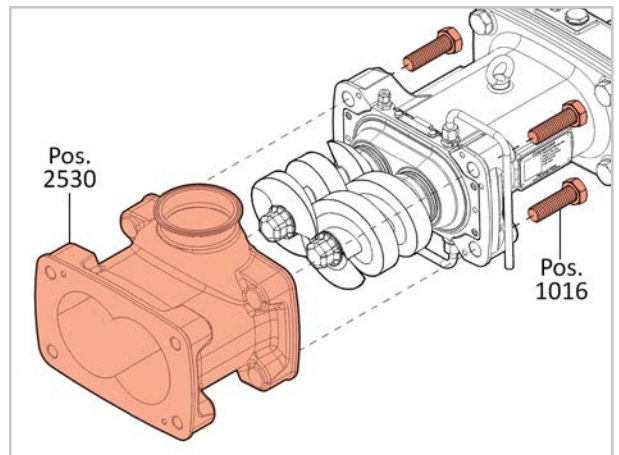
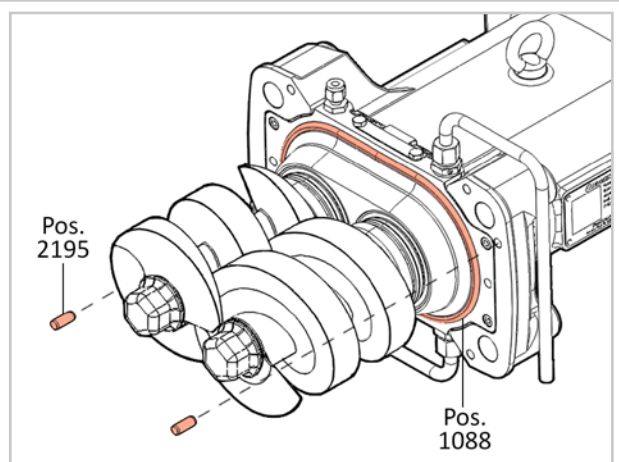

STEP 9)
INSTALLING THE PUMP FACE TO THE PUMP HOUSING

Install the Pump Face (Pos. 2528) to the Pump Housing (Pos. 2530). Verify that both Alignment Pins (Pos. 2196) are in position and O-ring (Pos. 2192) is correctly in place. Tighten the FOUR (4) Hex Screws (Pos. 2527) to 150 Nm.

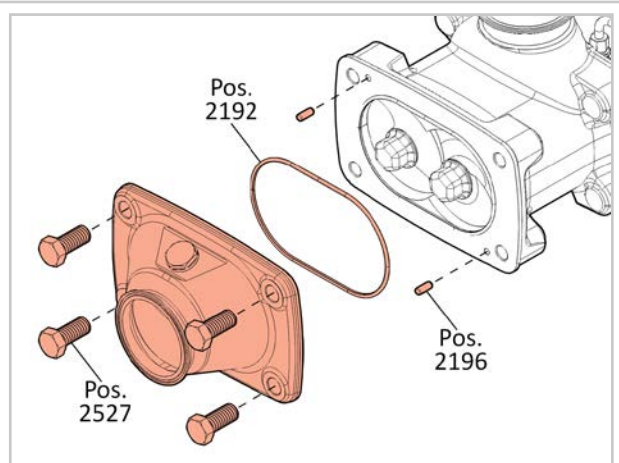

4.5 Preventative Maintenance Program

4.5.1 First Oil Change

A) The First Oil Change is required after 250 hours of operation, or 3 months (whichever comes first). This is known as the Break-In period.

4.5.2 Oil Change Intervals

A) After the first Oil Change is completed, sample & test the oil every 3 months for condensed water and debris.

B) Based on the results of the oil test, change if necessary. For more information about oils and oil testing, please see Section 5.6 "Oils, Grease & Lubrication Recommended" on page 117 and Section 5.7 "Oil Testing Kit" on page 119.

C) As a rule of thumb, the oil should last for 2000 to 3000 operating hours, or approximately 6 months.

D) Humid Environments in Production can lead to a shorter interval requirement for oil changes. A clean and accurate amount of oil can help extend the lifespan of your bearing and pump performance, while lowering maintenance costs.

4.5.3 Checking Levels on Motor Gearbox Oil

If the pump is motorized with a gearmotor, the gearbox needs gear oil as well. Please follow the instructions in the Motor Manual.

4.5.4 Greasing Motor Bearings

A) Motor Bearings must be properly greased according to the Motor Manufacturer's recommendations, which is typically every 3 months. Failure to do so could result in the motor not operating at peak performance, and can possibly lead to permanent motor damage or improper motor function.

4.5.5 Check Condition of O-rings

There are THREE (3) O-rings that need to be inspected to be sure they are free from damage in order for the ViscoTwin pumps to work correctly:

- Pos. 2192 (O-rings for Pump Face)
- Pos. 2194 (O-rings for Spindle Screws)
- Pos. 1088 (O-rings for Seal Housing)

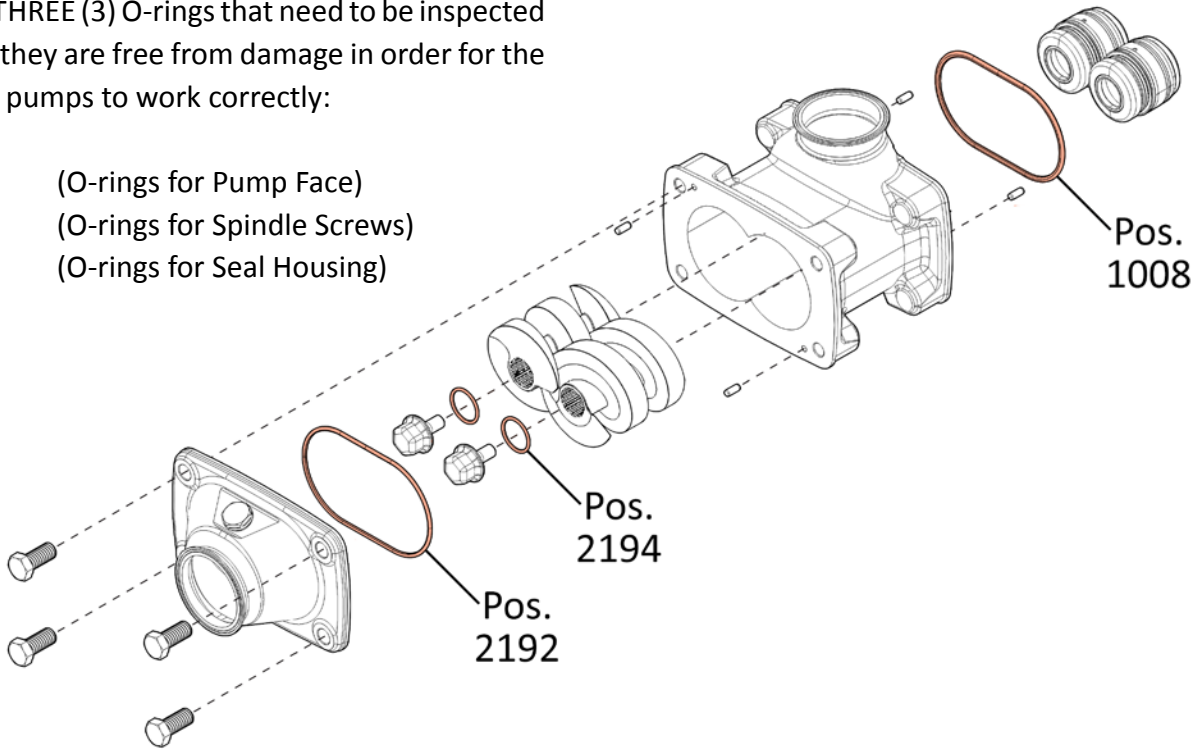

4.5.6 Check the Exterior Lip Seals and O-rings on the Mechanical Seals

Inspect the Lip Seal (1) and O-Rings (2, 3 & 4) at the locations shown below for signs of damage.



4.5.7 Check Oil Shaft Sealing Rings

Check the condition of the Oil Shaft Sealing Rings (Pos. 2322) on the Bearing Housing (Pos. 1001) and also the Oil Shaft Sealing Ring (Pos. 1010) on the Gear Housing (Pos. 2172).

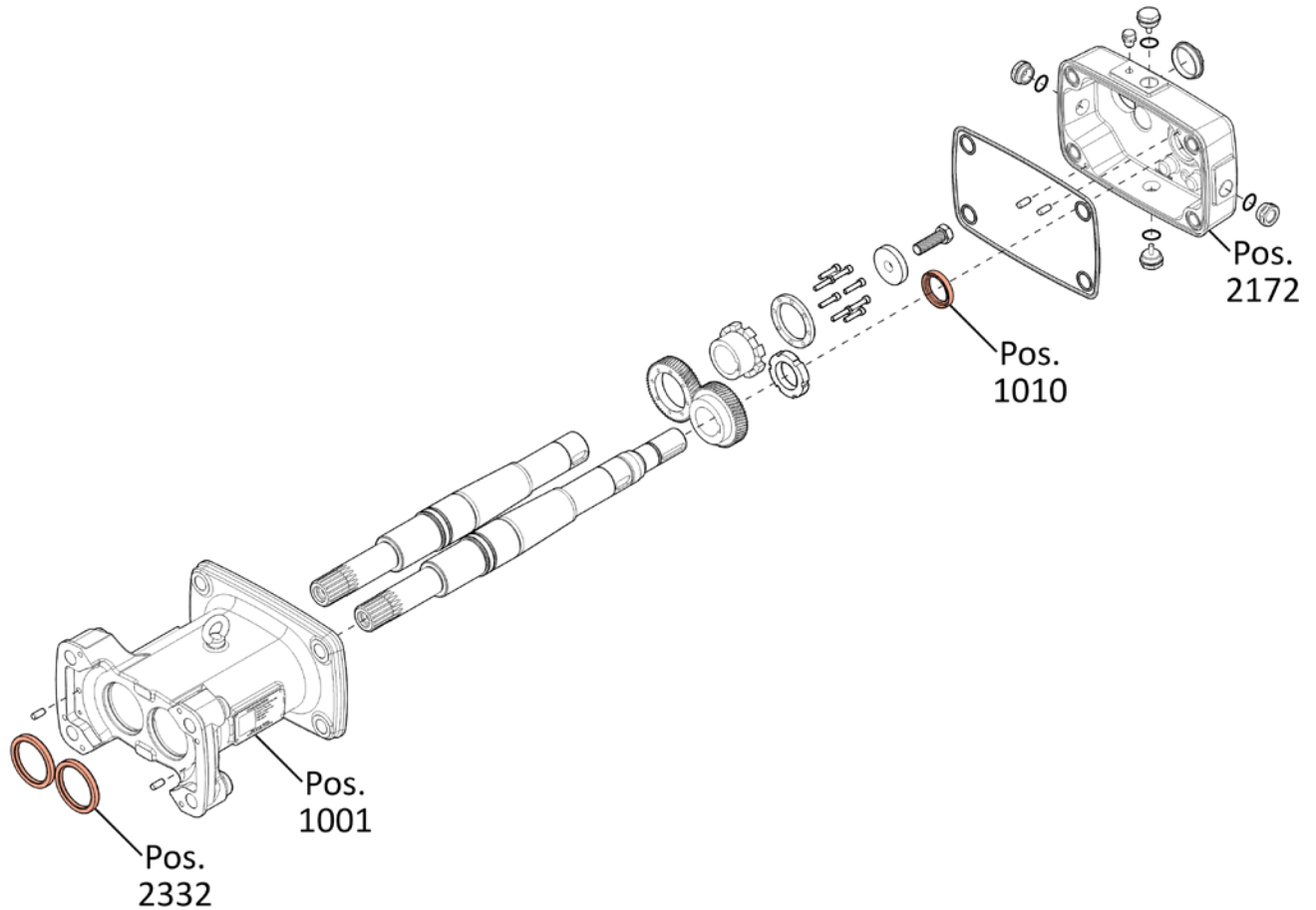

4.5.8 Proper Gapping of Pump

In case foreign material entered the pump housing and blocked the spindles, the gear synchronization lock ring (Pos. 2515) might have slipped. The “S” clearances between the spindles shifted to the extent that the spindles touch and block each other. In this case the pump needs to be gapped.

Gapping means that the “S” clearances between the spindle flights need to be evenly distributed while turning the driven shaft into the “middle position”. Successful gapping results in the “S” clearances measuring all the same (S10, S20, S30, S40).

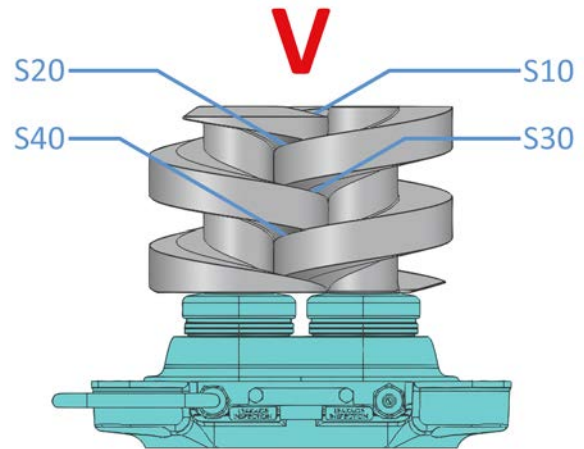

STEP 1)

Remove FOUR (4) Hex Head Cap Screws (Pos. 1016) and then remove the Pump Housing (Pos. 2530). The Pump Face (Pos. 2528) does not have to be removed from the Pump Housing (Pos. 2530).

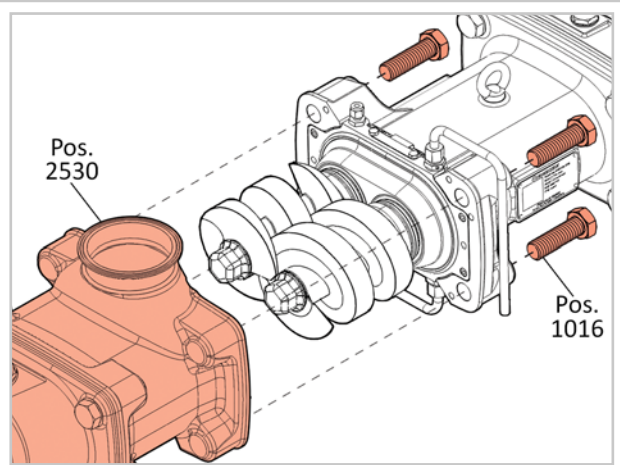

STEP 2)

Using a 24mm Socket, remove the Gapping Port Cover (Pos. 3100) from the Gear Housing (Pos. 2172). Now, loosen each of the EIGHT (8) Socket Head Cap Screws (Pos. 2186) while turning the Shaft by hand on the Spindles.

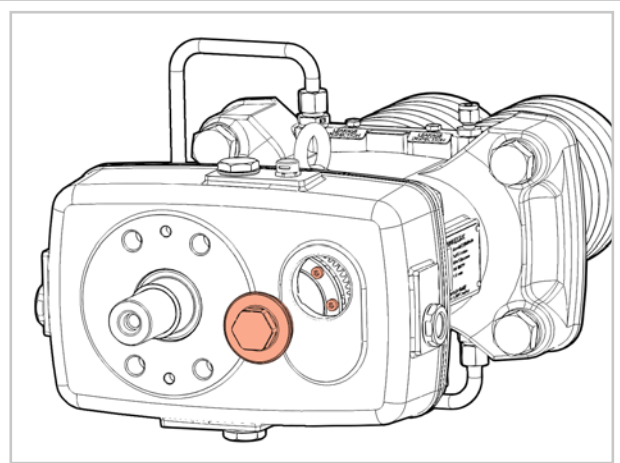

STEP 3)

Fixate the Drive Shaft (Pos. 1000) by holding the Drive Shaft Spindle (Pos. 2202) by hand, and turning the Driven Shaft Spindle (Pos. 2202) to one end with the other hand, until both spindles touch each other at position S20 and S40.

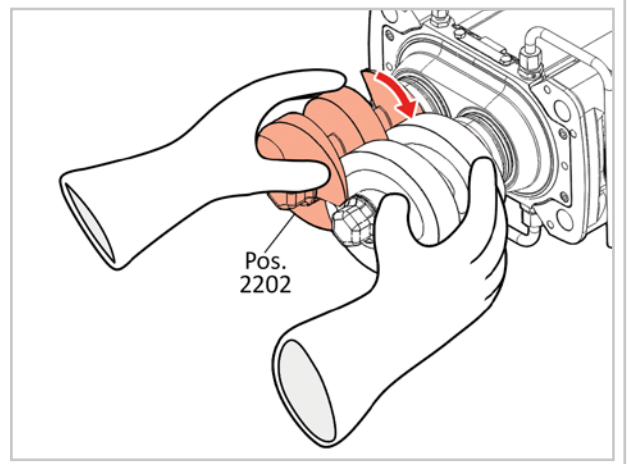

STEP 4)

Measure the gap position S30 with a feeler gauge. Divide that clearance in 2. (For example, if the clearance at S30 was 0.30mm, you will end up with .15mm). This is known as the "half-gap" dimension.

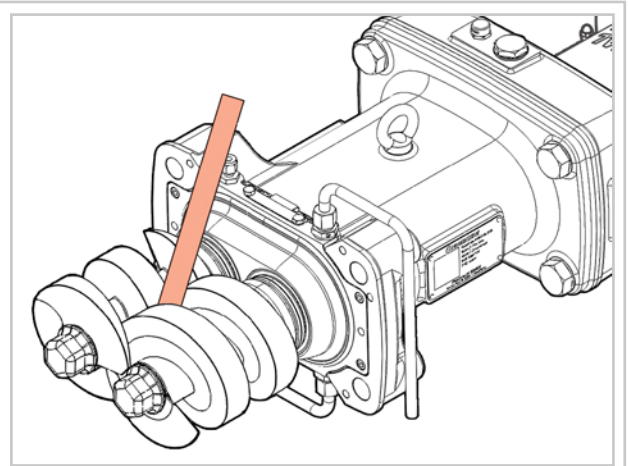

STEP 5)

Select a feeler gauge that is sized to this "half-gap" dimension, and insert it at S30, for use as a shim.

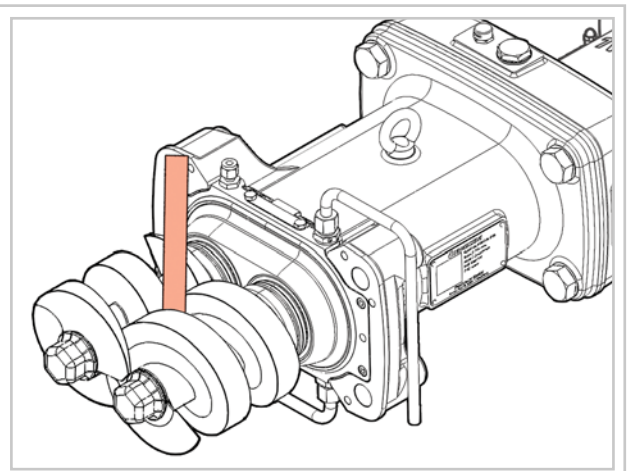

STEP 6)

Turn the Drive Shaft Spindle (Pos. 2202) until it closes onto the feeler gauge/shim at S30. If done correctly, this will now give you the exact same gap at S20.

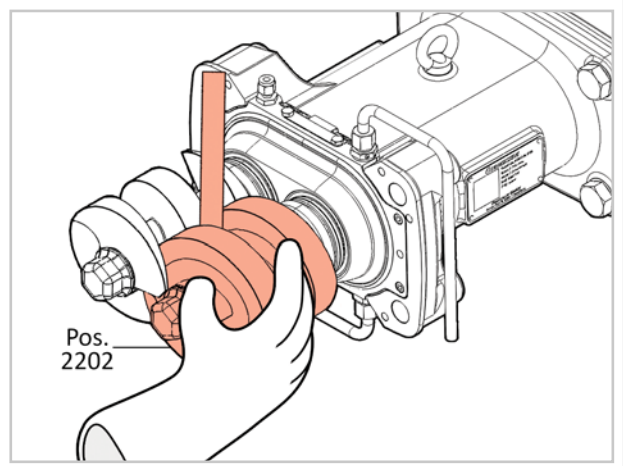

STEP 7)

Hand tighten just ONE (1) Socket Head Cap Screw (Pos. 2186). The shaft should be blocked and both spindles turn synchronized.

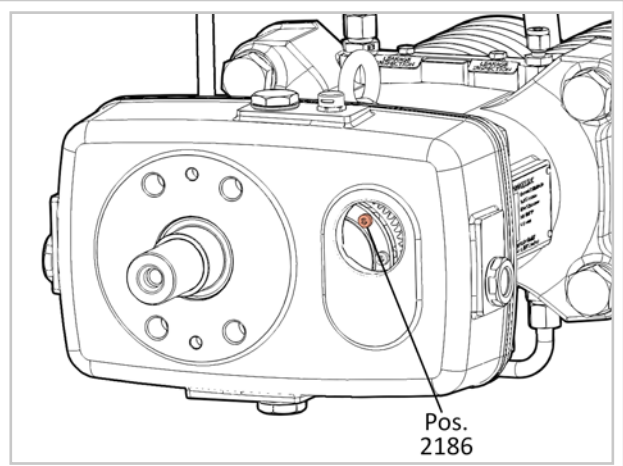

STEP 8)

Verify that S20 and S30 are now the same (or at least within .05mm). S10 will natively match with S30 and S20 will natively match with S40. Depending on the shape of the spindles used, a close value is good enough. The spindles are not allowed to touch anywhere, however. If that were to be the case, the spindles are severely damaged and probably need to be replaced.

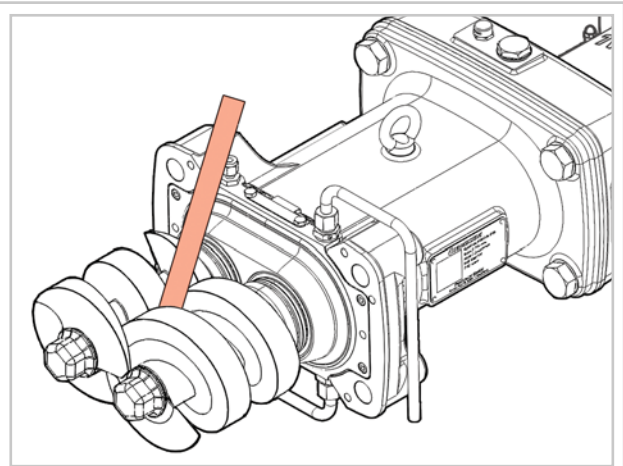

STEP 9)

While hand turning the Spindles (Pos. 2202), verify that the shafts turn freely. Also verify, by holding a white sheet of paper underneath the spindles and then shining a flashlight upwards, that the gaps are clear from galls as well.

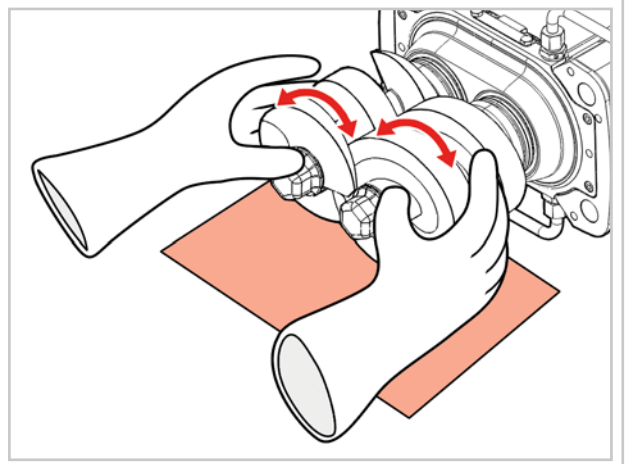

STEP 10)

Fixate the Gear Synchronization Lock Ring (Pos. 2515) by tightening the EIGHT (8) Socket Head Cap Screws (Pos. 2186) to 17 Nm (12.5 lb-ft.).

Now you can re-assemble the pump.

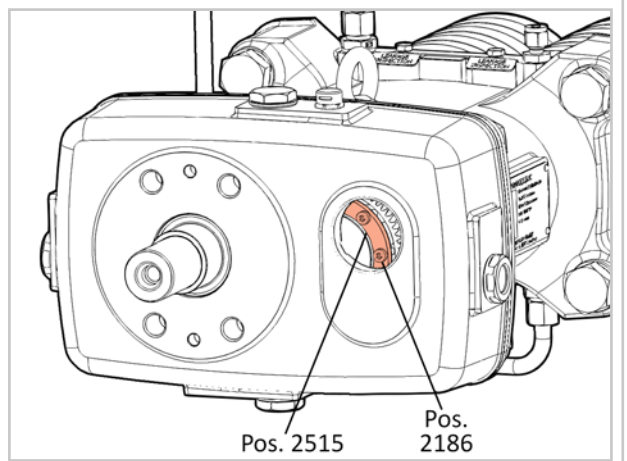

4.5.9 Changing Product Flow Direction

To change Product Flow Direction from any configuration, you will need to do **ONLY ONE** of the two following options:

OPTION 1

Change Spindle Arrangement from "V to A" or "A to V"

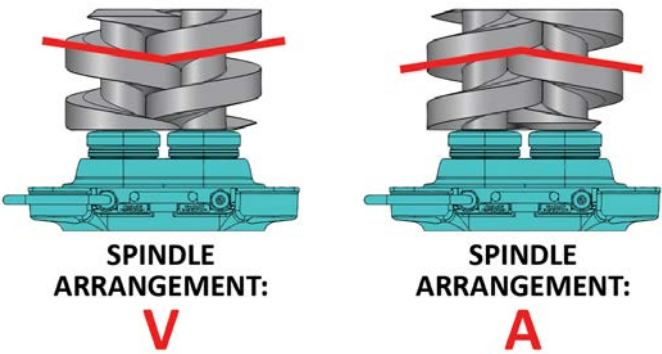

SPINDLE ARRANGEMENT: V

SPINDLE ARRANGEMENT: A

OR

OPTION 2

Step 1) Change Rotation from "O to I" or "I to O"

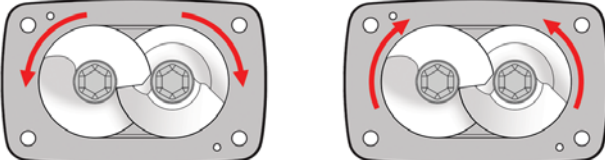

SHAFT ROTATION: OUTWARDS
requires clearance on the top

SHAFT ROTATION: INWARDS
requires clearance on bottom

Step 2) Switch the Pin Arrangement from "3 to 1" or "1 to 3"

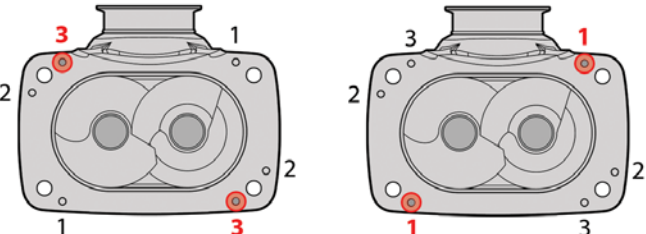

PIN CONFIGURATION: 3

PIN CONFIGURATION: 1

4.6 Failures

4.6.1 Foreign Material enters Pump Housing

STEP 1)

Remove FOUR (4) Hex Head Cap Screws (Pos. 1016) and then remove the Pump Housing (Pos. 2530). The Pump Face (Pos. 2528) does not have to be removed from the Pump Housing (Pos. 2530).

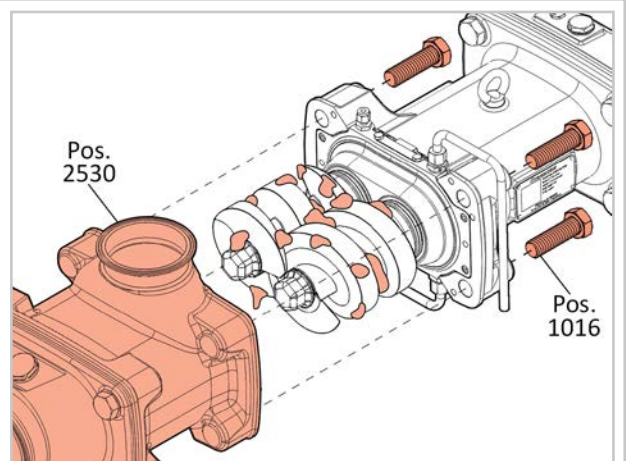

STEP 2)

Clean the Spindle Area by spraying with pressurized water.

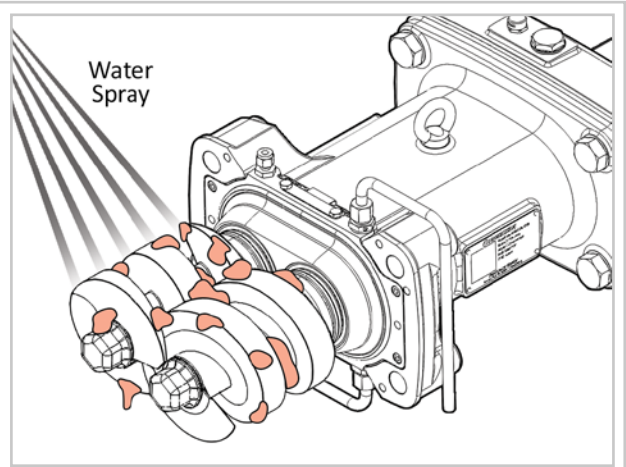

STEP 3)

Inspect the Drive Shaft (Pos. 1000) & Driven Shaft (Pos. 2171) for axial & radial movement by hand.

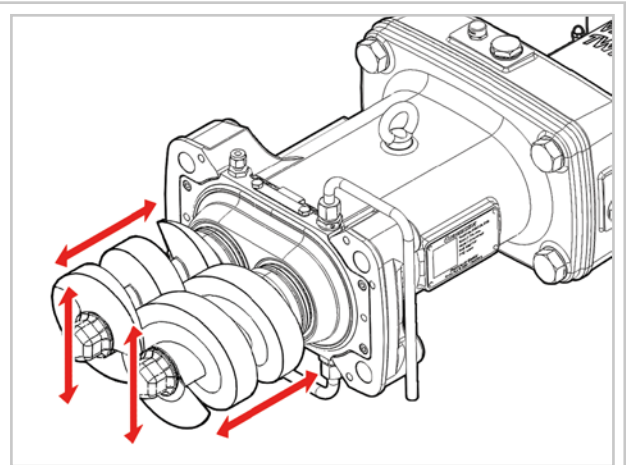

STEP 4)

Inspect if the Spindles (Pos. 2202) turn by hand. Visually inspect the condition of the Spindles (Pos. 2202).

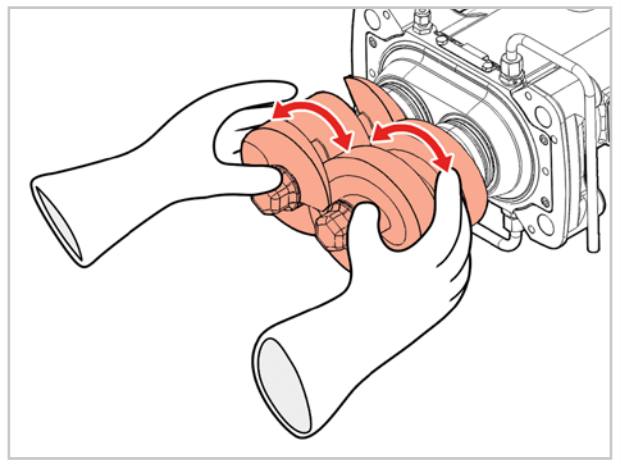

STEP 5)

Inspect the Spindles (Pos. 2202) and Pump Housing (Pos. 2530) condition for debris, scars, and crevices. If necessary, gap or time the Spindles (Pos. 2202).

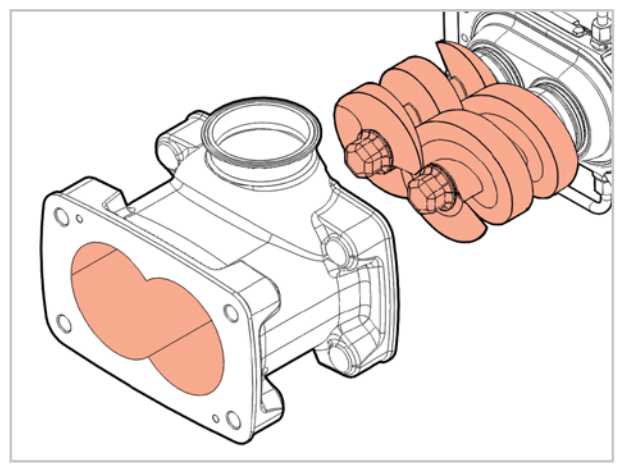

STEP 6)

Gapping and/or timing can be necessary if the Spindles (Pos. 2202) need to be replaced.

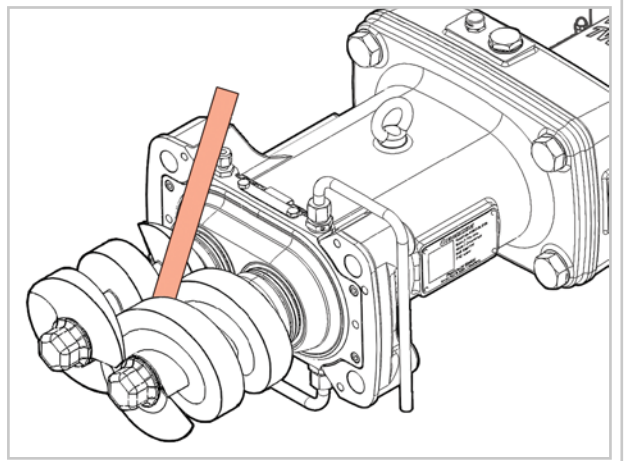



This page intentionally left blank.

5. TOOL-BOX

5.1 Tools

Below are all of the Tools that are available for purchase from **PROCESSTEC** for use on the **ViscoTwin** pumps:

5.1.1 ViscoTwin Tools

Complete Tool Box ML2 VT104 G7, G8+ NG, G10				--
Part #	Material	Description	Pump Generation	
22659	Various	Complete Tool Box Maintenance Level 2	G7, G8+, NG, G10	
<p>NOTES: To replace a missing or damaged tool, simply place an order with PROCESSTEC, Inc. using the part numbers that are listed on the following pages.</p>				

T0038 Hex Nut VT104, VT130 G7, G8+ NG, G10				for Pos. 2180
Part #	Material	Tool #	Pump Generation	
23254	Steel Oxidized, PLA insert	T0038	G7, G8+, NG, G10	
<p>NOTES: To loosen and tighten Hex Head Spindle Bolts.</p>				

T0047 Mounting Cone for Shaft Seal Ring Gear Housing VT104 G7, G8+ NG, G10				for Pos. 1010/1183
Part #	Material	Tool #	Pump Generation	
12587	304	T0047	G7, G8+, NG, G10	
<p>NOTES:</p>				

T0082 Press Fitting Mandrel Shaft Sealing Ring VT104_G7, G8+ NG, G10				for Pos. 1010
Part #	Material	Tool #	Pump Generation	
18776	304	T0082	G7, G8+, NG, G10	
<p>NOTES:</p>				

T0083 Mounting Cone Shaft Seal Ring Bearing Housing VT104 G7				for Pos. 1111
Part #	Material	Tool #	Pump Generation	
12569	304	T0083	G7	
NOTES:				

T0083 Mounting Cone Shaft Seal Ring Bearing Housing VT104 G8+, NG, G10				for Pos. 2322
Part #	Material	Tool #	Pump Generation	
23069	304	T0083	G8+, NG, G10	
NOTES:				

Pump Drive Shaft Blocking Tool				for Pos. 3000/2247
Part #	Material	Size	Pump Generation	
23812	304	VT70	G10	
21768	304	VT104	G10	
23472	304	VT130	G10	
NOTES:				

5.1.2 General Tools

Torque Wrench Large				--
Part #	Material	Size	Pump Generation	
21852	--	1/2" drive, 30-340 Nm	G7, G8+, NG	
<p>NOTES: For high torque application</p>				

Torque Wrench Medium				--
Part #	Material	Size	Pump Generation	
21851	--	3/8" drive, 10-135 Nm	G7, G8+, NG	
<p>NOTES: For medium torque application</p>				

Torque Wrench Small				--
Part #	Material	Size	Pump Generation	
21873	--	1/4" drive, 2.5-25 Nm	G7, G8+, NG	
<p>NOTES: For small torque application</p>				

Hex Nuts (Various Sizes)				for Pos. per Torque Table
Part #	Material	Size	Pump Generation	
21853	--	10mm (3/8" drive)	G7	
21854	--	13mm (1/2" drive)	G7	
21915	--	16mm (1/2" drive)	G7, G8+, NG	
22108	--	17mm (1/2" drive)	G8+, NG	
21910	--	18mm (1/2" drive)	G7	
21855	--	19mm (1/2" drive)	G7, G8+, NG	
21911	--	22mm (1/2" drive)	G7, G8+, NG	
21856	--	24mm (1/2" drive)	G7, G8+, NG	
21857	--	27mm (1/2" drive)	G7, G8+, NG	
21858	--	30mm (1/2" drive)	G7, G8+, NG	
21912	--	32mm (1/2" drive)	G7, G8+, NG	
<p>NOTES: Operate on positions per chart.</p>				

Hex Socket Bits Set (13 Piece)				for Pos. see notes
Part #	Material	Size	Pump Generation	
21828	CVS	2mm to 14mm	G7, G8+, NG	
<p>NOTES: Operate on positions per chart For Pos. 1008, 2246, 2247, 2248, 2258</p>				

Pliers				for Pos. 1183
Part #	Material	Size	Pump Generation	
21844	--	--	G7, G8+, NG	
NOTES:				

Hex Socket Screw Drivers				for Pos. see Notes
Part #	Material	Size	Pump Generation	
21913	--	7mm	G7, G8+, NG	
22405	--	8mm	G8+, NG	
21914	--	10mm	G7, G8+, NG	
NOTES:				
7mm used on Pos. 2287/3532				
8mm used on Pos. 3002				
10mm used on Pos. 2259/3533				

Feeler Gauge Metric				--
Part #	Material	Size	Pump Generation	
21847	303	--	G7, G8+, NG	
NOTES:				
Long blades to verify gaps in Spindles, Housing.				

Set of Small Hooks for Removal of O-Rings				--
Part #	Material	Size	Pump Generation	
21848	SS	--	G7, G8+, NG	
<p>NOTES: Operate on positions per chart</p>				

Hex Socket Extension				--
Part #	Material	Size	Pump Generation	
21874	--	9"	G7	
<p>NOTES: For 1/2" Drive</p>				

Breaker Wrench				for Pos. 4410
Part #	Material	Size	Pump Generation	
22488	--	18" Long (1/2" Drive)	G7, G8+, NG	
<p>NOTES:</p>				

Grease Tube				for Various Elastomers
Part #	Material	Size	Pump Generation	
22260	--	--	G7, G8+, NG	
NOTES:				

Open Spanner (Wrench) 10mm				for Pos. 3002
Part #	Material	Size	Pump Generation	
22489	--	10mm	G7, G8+, NG	
NOTES:				

Wrench for Operating Hex Nuts				for Pos. 2532/2533
Part #	Material	Size	Pump Generation	
21849	--	3/8" Drive	G7, G8+, NG	
21850	--	1/2" Drive	G7, G8+, NG	
NOTES:				

This page intentionally left blank.

5.2 Spare Parts

Below is a list of the Spare Parts that are available for purchase from **Processtec** for use on the **ViscoT-win** pumps:

5.2.1 Spare Parts for Pump Housing

Spindle Bolt VT104, VT130 G7, G8+, NG, G10				Pos. 2180
Part #	CUSTOMER REFERENCE #	Material	Specification	
23113		2205	Hex Style	
NOTES:				

O-Ring for Spindle Bolt VT104, VT130 G7, G8+, NG, G10				Pos. 2194
Part #	CUSTOMER REFERENCE #	Material	Specification	
12504		FKM	DIN3771-42x3,0	
12510		EPDM	DIN3771-42x3,0	
NOTES:				

Spindle Pairs VT104 G10				Pos. 2202
Part #	Specific Model Name	Material	Specification	
12639	Spindles (One Pair) VT104.27H3A	316L	27mm Hardened, 3A	
18489	Spindles (One Pair) VT104.36H3A	316L	36mm Hardened, 3A	
17516	Spindles (One Pair) VT104.53H3A	316L	53mm Hardened, 3A	
<p>NOTES:: Rotation Direction</p> 				

Hex Head Cap Screw for Pump Face VT104 G8+, NG, G9, G10				Pos. 2527
Part #	CUSTOMER REFERENCE #	Material	Specification	
21762		A270	ISO4017 - M16 x 40	
NOTES:				

Pump Face VT104 G10				Pos. 2528
Part #	CUSTOMER REFERENCE #	Material	Specification	
23645		FC316L	OD 3", ASME/DIN11866_C	
23646		FC316L	OD 4", ASME/DIN11866_C	
NOTES:				

Pump Housing VT104 G10				Pos. 2530
Part #	CUSTOMER REFERENCE #	Material	Specification	
23680		FC316L	OD 2-1/2", ASME/ DIN11866_C	
23644		FC316L	OD 3", ASME/DIN11866_C	
NOTES:				

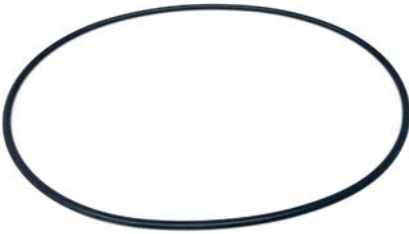
O-Ring for Pump Face VT104 G7, G8+, NG, G9, G10				Pos. 2192
Part #	CUSTOMER REFERENCE #	Material	Specification	
12505		FKM	DIN3771-155x4,0	
12511		EPDM	DIN3771-155x4,0	
NOTES:				

Dowel Pin for Pump Face & Housing VT70, VT104, VT130 G8+, NG, G9, G10				Pos. 2195, 2196
Part #	CUSTOMER REFERENCE #	Material	Specification	
12616	--	303	DIN7-8h8x20 US	
NOTES:				

Aseptoflex Plug for Sensor Port VT104, VT130 G8+, NG, G9, G10				Pos. 3050
Part #	CUSTOMER REFERENCE #	Material	Specification	
22252		316L	1 x 24 x 2 DIN 3869-33-FKM	
NOTES:				

Hex Head Cap Screw for Pump Face VT104 G8+, NG, G9, G10				Pos. 3050a
Part #	CUSTOMER REFERENCE #	Material	Specification	
22948		FKM	ID: 29.7mm x OD: 35.7mm	
NOTES:				

Hex Head Cap Screw for Pump Face VT104 G8+, NG, G9, G10				Pos. 3050b
Part #	CUSTOMER REFERENCE #	Material	Specification	
22253		FKM	24 x 2mm	
NOTES:				

5.2.2 Spare Parts for Seal Housing

O-Ring Seal Housing VT104 G7, G8+, NG, G9, G10				Pos. 1088
Part #	CUSTOMER REFERENCE #	Material	Specification	
12503		FKM	DIN3771-142x6,2	
12512		EPDM	DIN3771-142x6,2	
NOTES:				

Elastomer Kit - DAMS H I VT104 G10				Pos. 2535 EK
Part #	CUSTOMER REFERENCE #	Material	Specification	
--		FKM	HUHNSEAL, SD: 42mm	
--		EPDM	HUHNSEAL, SD: 42mm	
NOTES:				

Elastomer Kit - DAMS H C VT104 G10				Pos. 2535 EK
Part #	CUSTOMER REFERENCE #	Material	Specification	
--		FKM	HUHNSEAL, SD: 42mm	
--		EPDM	HUHNSEAL, SD: 42mm	
NOTES: Includes Pos. 110, 140, 180, 220, and 230				

Mechanical Seal DAMS VT104 G10				Pos. 2535
Part #	CUSTOMER REFERENCE #	Material	Specification	
23673		SIC/SIC FKM	HUHNSEAL, SD: 42mm	
23850		SIC/SIC EPDM	HUHNSEAL, SD: 42mm	
23555		TuC/TuCKE FKM	HUHNSEAL, SD: 42mm	
21566		TuC/TuCKE EPDM	HUHNSEAL, SD: 42mm	
NOTES:				

Male Connector Straight G3/8 - T1/4				Pos. 1863
Part #	CUSTOMER REFERENCE #	Material	Specification	
21690		316	G-3/8" x 1/4" Tubing	
NOTES:				

Male Connector Straight G3/8 - T3/8				Pos. 1864
Part #	CUSTOMER REFERENCE #	Material	Specification	
21689		316	G-3/8" x 3/8" Tubing	
NOTES:				

Seal Housing VT104 G10				Pos. 2188
Part #	CUSTOMER REFERENCE #	Material	Specification	
23611		316L	3A	
NOTES:				

Hex Socket Screw for Seal Housing VT104 G10				Pos. 2259
Part #	CUSTOMER REFERENCE #	Material	Specification	
19366		A270	20mm, HHS: 6mm	
NOTES:				

Safety Guard VT104 G10				Pos. 2546
Part #	CUSTOMER REFERENCE #	Material	Specification	
23617		304	20mm, HHS: 6mm	
NOTES:				

5.2.3 Spare Parts for Bearing Housing

Key for Coupling VT104 G7, G8+, NG, G9, G10				Pos. 1183
Part #	CUSTOMER REFERENCE #	Material	Specification	
12618		316	DIN6885-AS 8x7x32	
NOTES:				

Shaft Sealing Ring Bearing Housing VT104 G10				Pos.2322
Part #	CUSTOMER REFERENCE #	Material	Specification	
23773		FKM	DIN3760-AS 55x70x8	
NOTES:				

Dowel Pin for Seal Housing VT104, VT130 G8+, NG, G9, G10				Pos. 2536
Part #	CUSTOMER REFERENCE #	Material	Specification	
21903		303	DIN7-8h8x24 US	
NOTES:				

Drive Shaft VT104 G10				Pos. 1000
Part #	CUSTOMER REFERENCE #	Material	Specification	
23615		316	Replaceable Sleeves	
<p>NOTES: Replaceable sleeve at oil sealing ring positions</p>				

Shaft Protection Sleeve Gear Housing VT104 G8+ NG G9 G10				Pos. 2675
Part #	CUSTOMER REFERENCE #	Material	Specification	
23400		SS	Hard Inox S Treated	
<p>NOTES:</p>				

Hex Head Cap Screw Gear Housing VT104 G8+, NG, G9, G10				Pos. 1016, 2258
Part #	CUSTOMER REFERENCE #	Material	Specification	
22418		A270	ISO4017 - M16 x 55	
<p>NOTES:</p>				

O-Ring for Shaft Protection Sleeve Gear Housing VT104 G8+, NG, G9, G10				Pos. 2676
Part #	CUSTOMER REFERENCE #	Material	Specification	
23399		FKM	DIN3771 - 25,12x1,78mm	
NOTES:				

Shaft Protection Sleeve Bearing Housing VT104 G10				Pos. 2677
Part #	CUSTOMER REFERENCE #	Material	Specification	
23705		SS	Hard Inox S Treated	
NOTES:				

O-Ring for Shaft Protection Sleeve Bearing Housing VT104 G10				Pos. 2678
Part #	CUSTOMER REFERENCE #	Material	Specification	
23704		FKM	ISO3601 - 1,47.5x1,8mm	
NOTES:				

Driven Shaft VT104 G10 S				Pos. 2171
Part #	CUSTOMER REFERENCE #	Material	Specification	
23616		316	Replaceable sleeve	
<p>NOTES: Replaceable sleeve at oil sealing ring positions</p>				

Bearing Housing VT104 G10				Pos. 1001
Part #	CUSTOMER REFERENCE #	Material	Specification	
23649		FC304	--	
<p>NOTES:</p>				

Eyebolt VT70 VT104 VT130 G10				Pos. 1001a
Part #	CUSTOMER REFERENCE #	Material	Specification	
23579		304	DIN580 - M10	
<p>NOTES:</p>				

Needle Roller Bearing VT104 G7 G8+, NG, G9, G10				Pos. 1003
Part #	CUSTOMER REFERENCE #	Material	Specification	
19099		--	--	
NOTES:				

Lock Snap Ring VT104 G7, G8+, NG, G9, G10				Pos. 1009 a, b
Part #	CUSTOMER REFERENCE #	Material	Specification	
19316		--	--	
NOTES:				

Spacer Sleeve for Bearings VT104 G8+ NG G9 G10				Pos. 1529
Part #	CUSTOMER REFERENCE #	Material	Specification	
22070		SS	--	
NOTES:				

Angular Ball Bearing VT104 G7, G8+, NG, G9, G10				Pos. 2181
Part #	CUSTOMER REFERENCE #	Material	Specification	
21963		--	--	
NOTES:				

Gear Wheel Key for Drive & Driven Shaft VT104 G8, NG, G9, G10				Pos. 2179
Part #	CUSTOMER REFERENCE #	Material	Specification	
22256		SS	DIN6885-AS 10 x 8 x 32	
NOTES:				

Venting Valve VT70 VT104 VT130 G7, G8+, NG, G9, G10				Pos. 2232
Part #	CUSTOMER REFERENCE #	Material	Specification	
18757		304	1/4"	
NOTES:				

5.2.4 Spare Parts for Gear Housing

Shaft Sealing Ring Gear Housing VT104_G8+, NG, G9 G10				Pos. 1010
Part #	CUSTOMER REFERENCE #	Material	Specification	
21905		FKM	DIN 3760-AS-32x52x7 SD: 45mm	
NOTES:				

Magnetic Screw Plug VT70, VT104, VT130 G8+, NG, G9, G10				Pos. 2333
Part #	CUSTOMER REFERENCE #	Material	Specification	
21767		Alum.	DIN910, Size G3/4"	
23114		FKM	Pos. 2333a, Gasket for Sight Gauge and Magnetic Screw Plug (5 Pack)	
NOTES:				

Oil Level Sight Gauge_VT70, VT104, VT130_G7, G8+, NG, G10				Pos. 2360
Part #	CUSTOMER REFERENCE #	Material	Specification	
21766		Aluminum Glass	Size G3/4"	
23114		FKM	Pos. 2360a, Gasket for Sight Gauge and Magnetic Screw Plug (5 Pack)	
NOTES:				

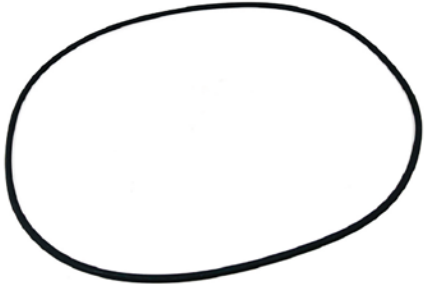
O-Ring Large for Gear Housing VT104 G8+ NG, G9, G10				Pos. 2513
Part #	CUSTOMER REFERENCE #	Material	Specification	
21764		FKM	DIN3771-237x4,0	
NOTES:				

O-Ring Small for Gear Housing VT104 G8+ NG, G9, G10				Pos. 2514
Part #	CUSTOMER REFERENCE #	Material	Specification	
21765		FKM	DIN3771-18,5x2,0	
NOTES: Sold in sets of 4.				

Gear Oil Bearing Housing VT				
Part #	CUSTOMER REFERENCE #	Material	Specification	
21871		--	1 Liter, Food Grade	
NOTES:				

Hex Socket Screw for Bearing Cover VT70 VT104 VT130 G7, G8+ NG, G9, G10				Pos. 1008
Part #	CUSTOMER REFERENCE #	Material	Specification	
19341		Steel 10.9	DIN6912 - M8 x 25 B=22mm, Low Profile Socket Head	
NOTES:				

Bearing Cover VT104 G7, G8+ NG, G9, G10				Pos. 1227
Part #	CUSTOMER REFERENCE #	Material	Specification	
19096		C45	--	
NOTES:				

Gear Wheel Nut for Drive Shaft VT104 G7, G8+ NG, G9, G10				Pos. 1526
Part #	CUSTOMER REFERENCE #	Material	Specification	
19320		SS	--	
NOTES:				

Gear Housing Right VT104 G10				Pos. 2172
Part #	CUSTOMER REFERENCE #	Material	Specification	
23648		FC304	Right, Housing with Gapping Port	
NOTES:				

Gear Housing Left VT104 G10				Pos. 2172
Part #	CUSTOMER REFERENCE #	Material	Specification	
23647		FC304	Left, Housing with Gapping Port	
NOTES:				

Gapping Port Plug VT104 G10				Pos. 3100
Part #	CUSTOMER REFERENCE #	Material	Specification	
23557		304	40mm	
NOTES:				

O-Ring for Gapping Port Plug VT70 VT104 G10				Pos. 3100a
Part #	CUSTOMER REFERENCE #	Material	Specification	
23669		FKM	OR 38 x 1.5	
NOTES:				

Gear Wheel Collar Driven Shaft VT104 G8+ NG, G9, G10				Pos. 2176
Part #	CUSTOMER REFERENCE #	Material	Specification	
22420		304	--	
NOTES:				

Hex Bolt for Driven Shaft VT104 VT130 G8+ NG, G9, G10				Pos. 2177
Part #	CUSTOMER REFERENCE #	Material	Specification	
22335		Steel 12.9	ISO4017 - M16 x 50	
NOTES:				

Press Ring Gear Wheel Driven Shaft VT104 G8+ NG, G9, G10				Pos. 2178
Part #	CUSTOMER REFERENCE #	Material	Specification	
22436		304	--	
NOTES:				

Gear Wheel Drive Shaft VT104 G8+ NG, G9, G10				Pos. 2183
Part #	CUSTOMER REFERENCE #	Material	Specification	
22337		AISI 5115, hardened	49teeth, b: 36.5mm, Module 1,5	
NOTES:				

Gear Wheel Driven Shaft VT104 G8+ NG, G9, G10				Pos. 2184
Part #	CUSTOMER REFERENCE #	Material	Specification	
22338		AISI 5115, hardened	49teeth, b: 36.5mm, Module 1,5	
NOTES:				

Hex Socket Screw for Gear Synchronization Lock Ring VT104 G8+ NG, G9, G10				Pos. 2186
Part #	CUSTOMER REFERENCE #	Material	Specification	
22332		Steel 12.9	ISO4762 - M6 x 25mm	
NOTES:				

Dowel Pin for Gear Housing G7 G8+ NG, G9, G10				Pos. 2256
Part #	CUSTOMER REFERENCE #	Material	Specification	
18764		303	8 x 8 x 20mm, US	
NOTES:				

Gear Synchronization Lock Ring VT104 G8+ NG, G9, G10				Pos. 2515
Part #	CUSTOMER REFERENCE #	Material	Specification	
22027		304	--	
NOTES:				

5.2.5 Spare Parts for Drive Train

Coupling Hub Pump_VT104_G8+ NG, G10				Pos. 2247
Part #	CUSTOMER REFERENCE #	Material	Specification	
21702		Alum.	BS: 28mm, SIT	
NOTES:				

Coupling Hub Motor_VT104_G8+ NG, G10				Pos. 2248
Part #	CUSTOMER REFERENCE #	Material	Specification	
21704		Alum.	BS: 1-3/8"	
21705		Alum.	BS: 1-5/8"	
21706		Alum.	BS: 1-7/8"	
21707		Alum.	BS: 2-1/8"	
22196		Alum.	BS: 2-3/8"	
NOTES: Size might change due to motor size. Please consult configuration key or contact PROCESSTEC .				

Coupling Spider VT104, VT130 G8+ NG, G10				Pos. 2249
Part #	CUSTOMER REFERENCE #	Material	Specification	
7115		PU	98 42/55-Red, SIT	
NOTES:				

Coupling Hub Pump VT104 G8+, NG, G10				Pos. 2247
Part #	Material	Size	Specification	
23178	Aluminum	--	BS: 28mm, R+W	
NOTES:				

Coupling Hub Motor_VT104_G8+, NG				Pos. 2248
Part #	Material	Size	Specification	
23241	Aluminum	--	SD: 1-3/8" R+W	
23237	Aluminum		SD: 1-5/8" R+W	
23236	Aluminum		SD: 1-7/8" R+W	
23176	Aluminum		SD: 2-1/8" R+W	
NOTES: Size might change due to motor size. Please consult configuration key or contact PROCESSTEC .				

Coupling Spider_VT104, VT130_G8+, NG				Pos. 2249
Part #	Material	Size	Specification	
23243	TPU	--	Servomax EK-150, R+W	
NOTES:				

W22 Severe Duty Motor (with C-Face)				Pos. 3003
Part #	Material	Size	Pump Generation	
--	variable	--	variable	
<p>NOTES: Size might change due to application requirements. Please contact PROCESSTEC Inc. for more details.</p>				

5.3 Explosion Drawings

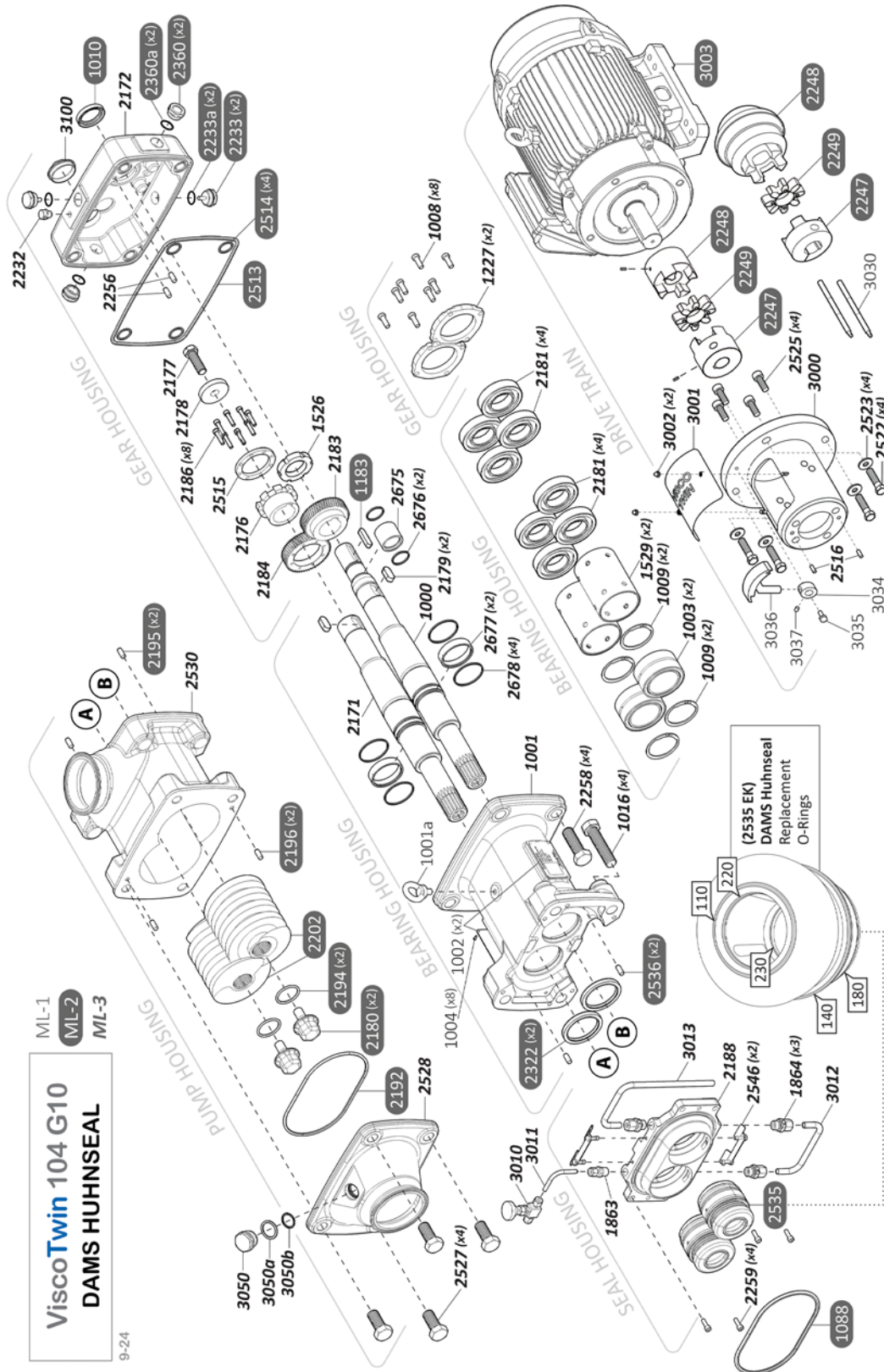

5.5 Pump Housing Configuration

Each **ViscoTwin 104 G10** Pump Housing can be set up for a variety of configuration options to suit particular application.

Each Configuration has been uniquely identified with a series of letters and numbers that call out the specific flow direction, shaft rotation, pin positions and spindle arrangements to get the desired output.

For example, a **FHO3V** configuration means that the Flow Direction is Face In/Housing Out (FH), Shaft Rotation is Outward (O), Pin Position is Configuration 3 (3) with Spindle Arrangement V (V).

There are SIX possible configurations, and each one is listed in the chart below, as well on the following pages. The default configuration is **FHI1A**.

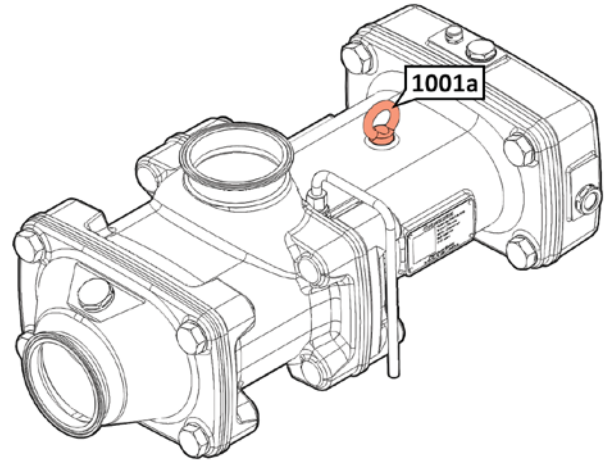

The TOP of the pump is always determined by the location of the Eye-Hook (Pos. 1001a) on the Bearing Housing, regardless of the Pump Housing orientation and the final position of the Pump.

CONFIGURATION NAME	FLOW DIRECTION	SPINDLE ROTATION	PIN POSITION	SPINDLE ARRANGEMENT	COMMENTS
FHO3V	Face In / Housing Out	Outwards	3	V	Product dragged along the bottom
FHI1A	Face In / Housing Out	Inwards	1	A	Product dragged along the top
HFI1V	Housing In / Face Out	Inwards	1	V	Product dragged along the top
HFO3A	Housing In / Face Out	Outwards	3	A	Product dragged along the bottom
BDB2V	Bi-Directional	Bi-Directional	2	V	Limited Viscosity Tapered Spindles Preferred
BDB2A	Bi-Directional	Bi-Directional	2	A	Limited Viscosity Tapered Spindles Preferred

Flow Direction (figure 1)

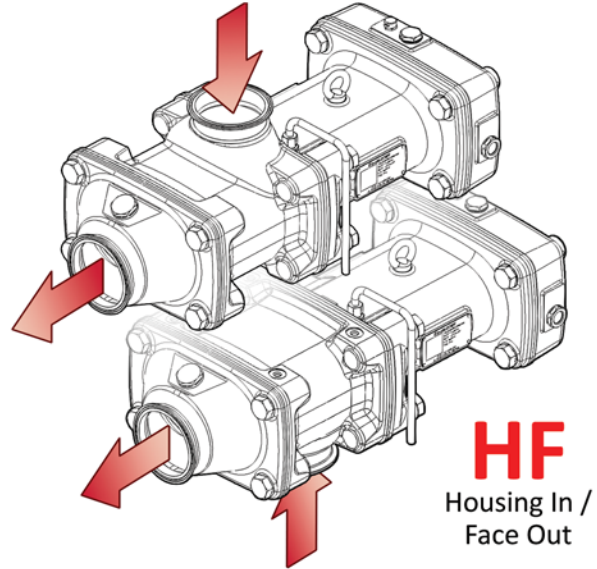
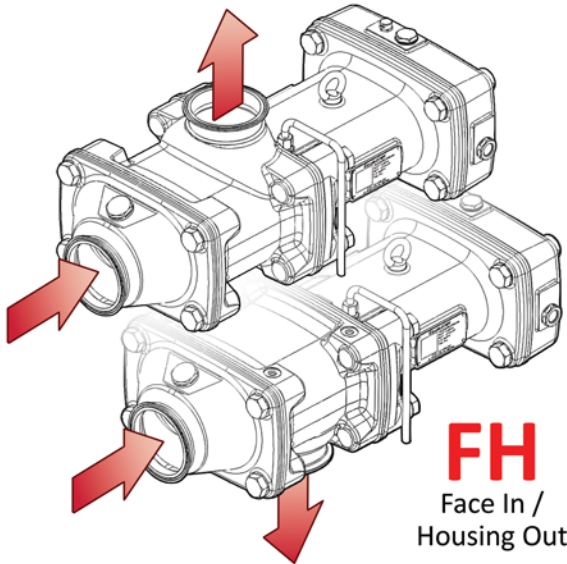

Shaft Rotation (figure 2)

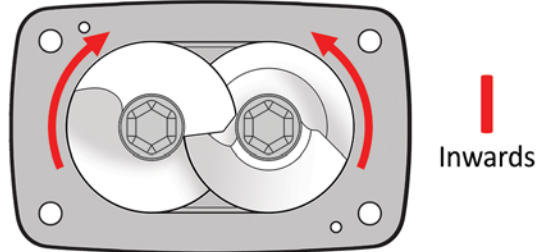
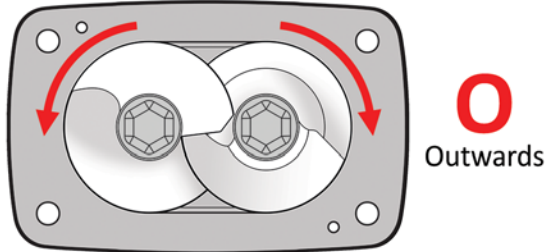

Pin Configuration (figure 3)

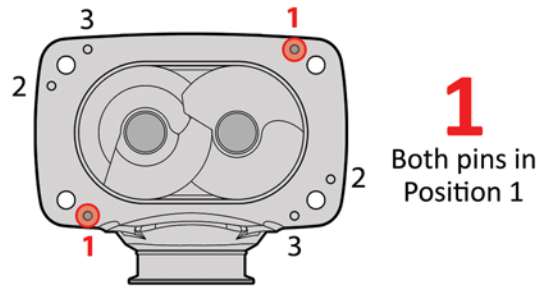
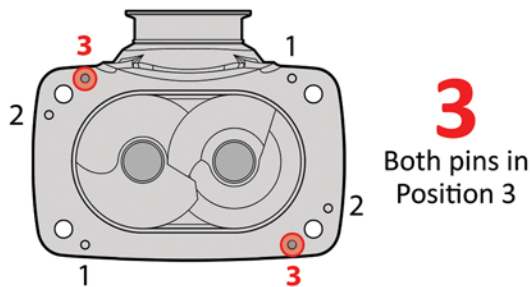

Spindle Arrangement (figure 4)

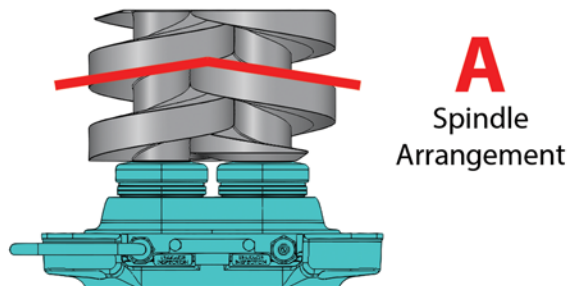
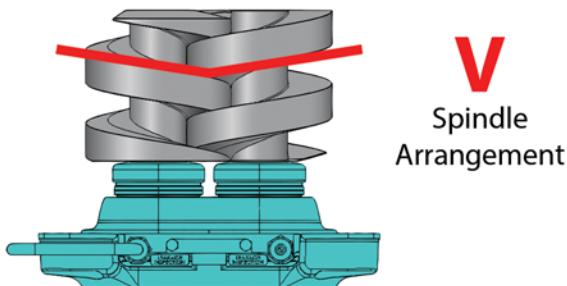

FHO3V (T)

FH - Face In / Housing Out
O - Outwards
3 - Pin Position 3
V - Spindle Arrangement V
T - Top

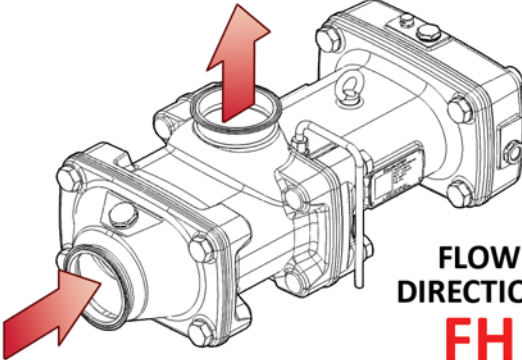

FLOW DIRECTION
FH

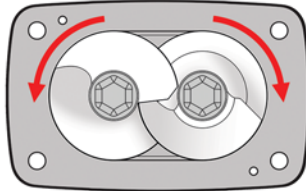

SHAFT ROTATION:
OUTWARDS
requires clearance on the top

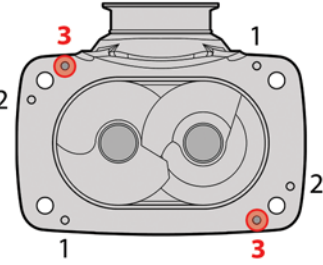

PIN CONFIGURATION:
3
delivers clearance on the top

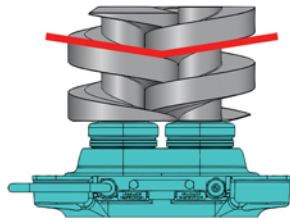

SPINDLE ARRANGEMENT:
V

FHO3V (B)

FH - Face In / Housing Out
O - Outwards
3 - Pin Position 3
V - Spindle Arrangement V
B - Bottom

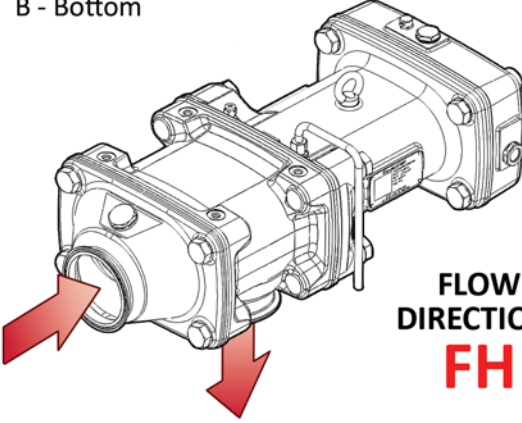

FLOW DIRECTION
FH

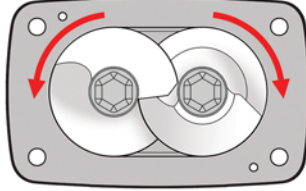

SHAFT ROTATION:
OUTWARDS
requires clearance on the top

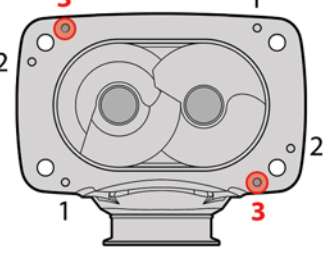

PIN CONFIGURATION:
3
delivers clearance on the top

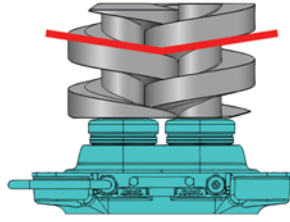

SPINDLE ARRANGEMENT:
V

FHI1A (T)

FH - Face In / Housing Out
I - Inwards
1 - Pin Position 1
A - Spindle Arrangement A
T - Top

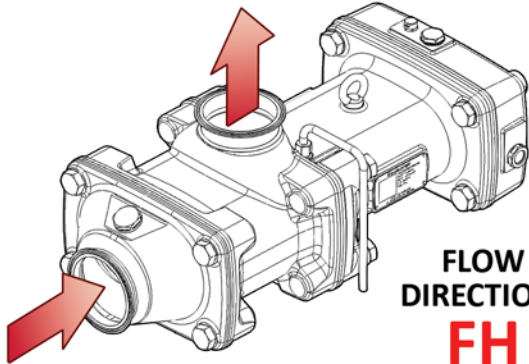

FLOW
DIRECTION:
FH

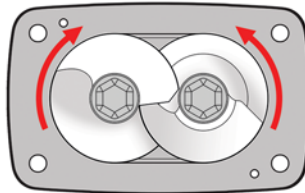

SHAFT ROTATION:

INWARDS

requires clearance on bottom

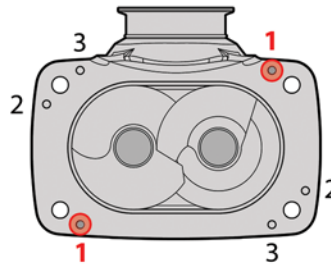

PIN CONFIGURATION:

1

delivers clearance on bottom

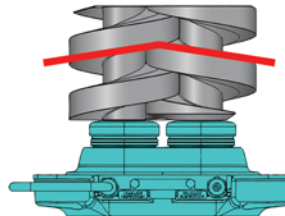

SPINDLE
ARRANGEMENT:

A

FHI1A (B)

FH - Face In / Housing Out
I - Inwards
1 - Pin Position 1
A - Spindle Arrangement A
B - Bottom

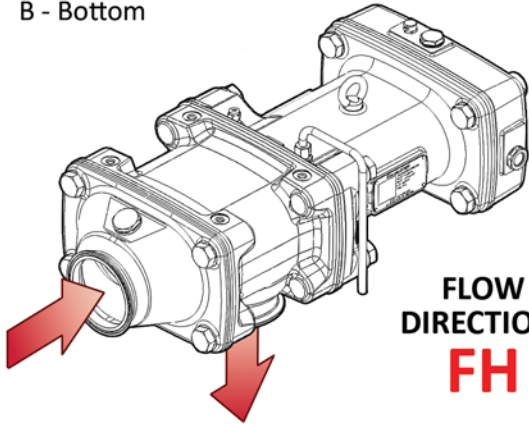

FLOW
DIRECTION:
FH

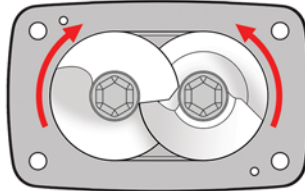

SHAFT ROTATION:

INWARDS

requires clearance on bottom

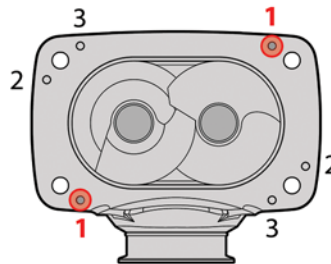

PIN CONFIGURATION:

1

delivers clearance on bottom

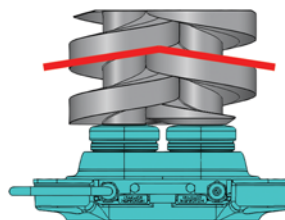

SPINDLE
ARRANGEMENT:

A

HFI1V (T)

HF - Housing In / Face Out
I - Inwards
1 - Pin Position 1
V - Spindle Arrangement V
T - Top

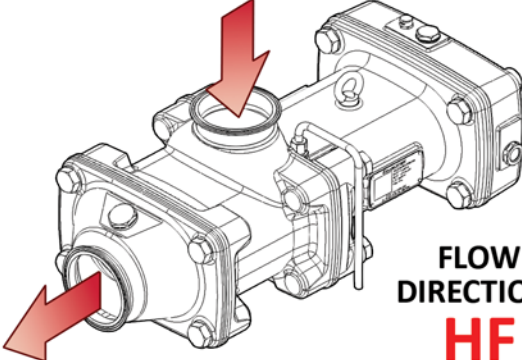

FLOW DIRECTION
HF

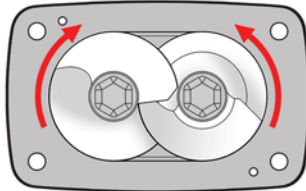

SHAFT ROTATION:
INWARDS
requires clearance on bottom

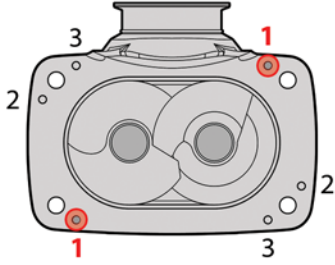

PIN CONFIGURATION:
1
delivers clearance on bottom

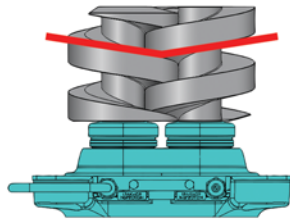

SPINDLE ARRANGEMENT:
V

HFI1V (B)

HF - Housing In / Face Out
I - Inwards
1 - Pin Position 1
V - Spindle Arrangement V
B - Bottom

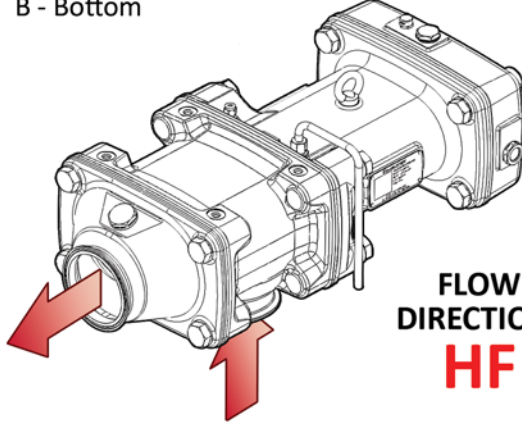

FLOW DIRECTION
HF

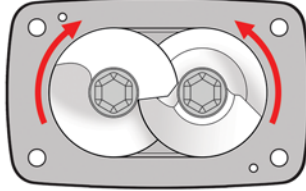

SHAFT ROTATION:
INWARDS
requires clearance on bottom

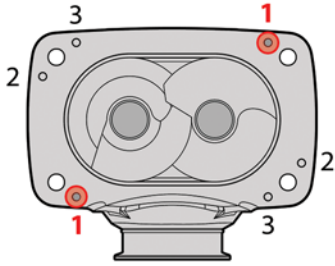

PIN CONFIGURATION:
1
delivers clearance on bottom

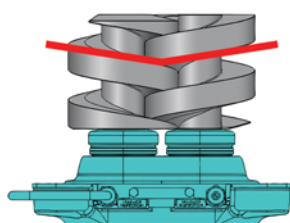

SPINDLE ARRANGEMENT:
V

HFO3A (T)

HF - Housing In / Face Out
O - Outwards
3 - Pin Position 3
A - Spindle Arrangement A
T - Top

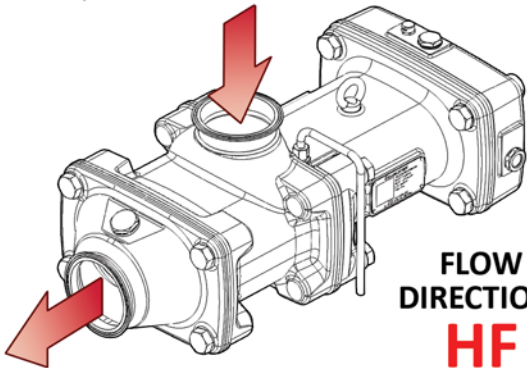

FLOW
DIRECTION:
HF

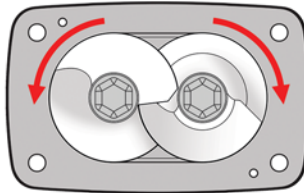

SHAFT ROTATION:
OUTWARDS

requires clearance on the top

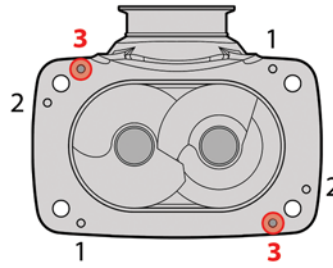

PIN CONFIGURATION:

3

delivers clearance on the top

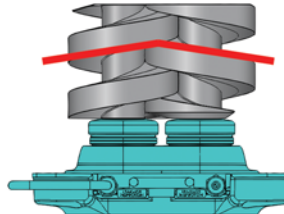

SPINDLE
ARRANGEMENT:
A

HFO3A (B)

HF - Housing In / Face Out
O - Outwards
3 - Pin Position 3
A - Spindle Arrangement A
B - Bottom

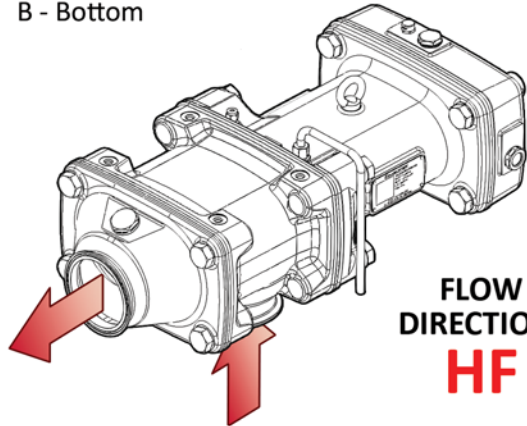

FLOW
DIRECTION:
HF

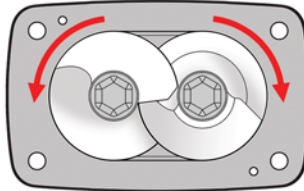

SHAFT ROTATION:
OUTWARDS

requires clearance on the top

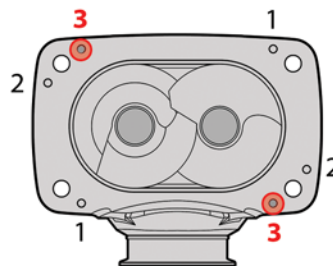

PIN CONFIGURATION:

3

delivers clearance on the top

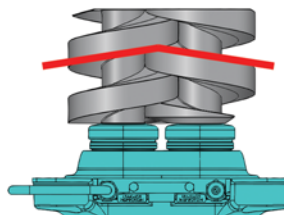

SPINDLE
ARRANGEMENT:
A

BDB2V (T)

BD - Bi-Directional
B - Bi-Directional
2 - Pin Position 2
V - Spindle Arrangement V
T - Top

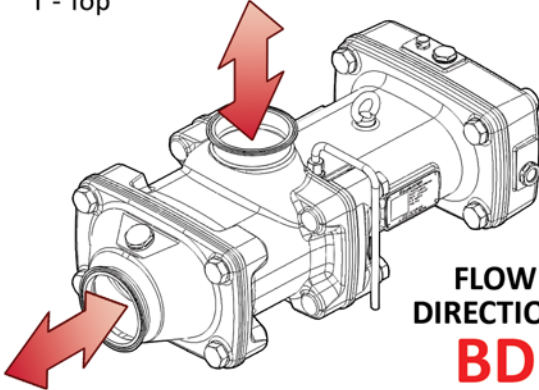

FLOW DIRECTION
BD

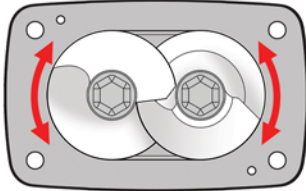

SHAFT ROTATION:
BI-DIRECTIONAL
evenly distributed clearance

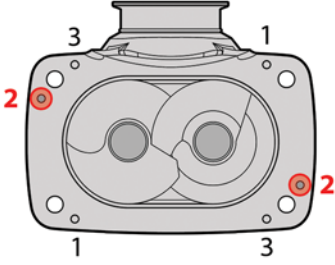

PIN CONFIGURATION:
2
evenly distributed clearance

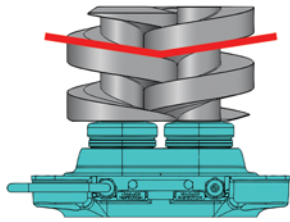

SPINDLE ARRANGEMENT:
V

BDB2V (B)

BD - Bi-Directional
B - Bi-Directional
2 - Pin Position 2
V - Spindle Arrangement V
B - Bottom

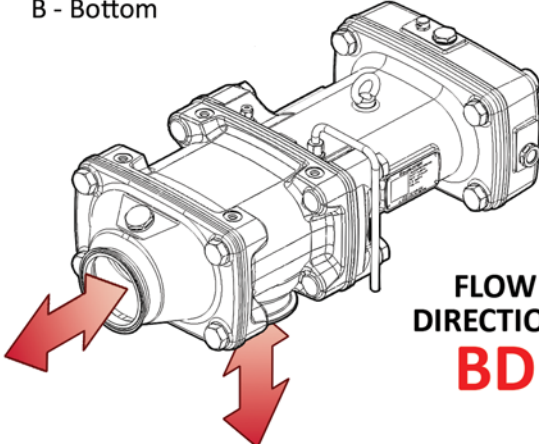

FLOW DIRECTION
BD

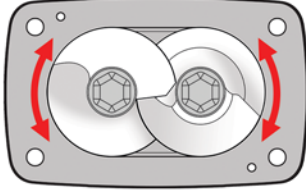

SHAFT ROTATION:
BI-DIRECTIONAL
evenly distributed clearance

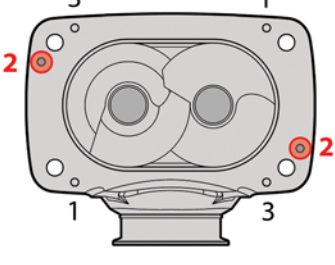

PIN CONFIGURATION:
2
evenly distributed clearance

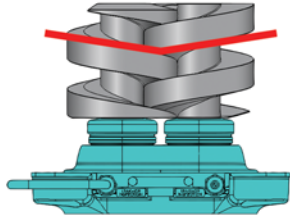

SPINDLE ARRANGEMENT:
V

BDB2A (T)

BD - Bi-Directional
B - Bi-Directional
2 - Pin Position 2
A - Spindle Arrangement A
T - Top

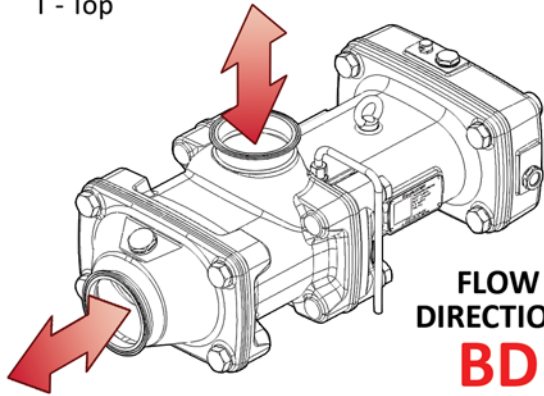

FLOW
DIRECTION:
BD

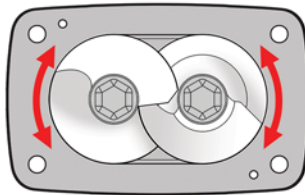

SHAFT ROTATION:
BI-DIRECTIONAL
evenly distributed clearance

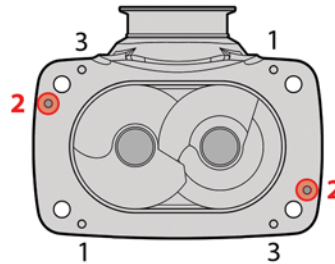

PIN CONFIGURATION:
2
evenly distributed clearance

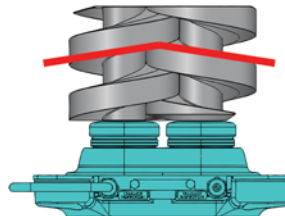

SPINDLE
ARRANGEMENT:
A

BDB2A (B)

BD - Bi-Directional
B - Bi-Directional
2 - Pin Position 2
A - Spindle Arrangement A
B - Bottom

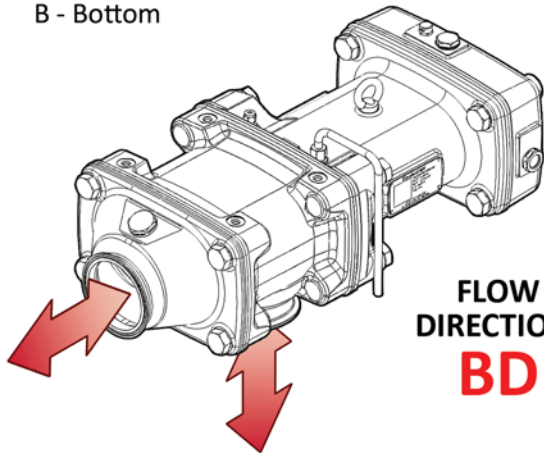

FLOW
DIRECTION:
BD

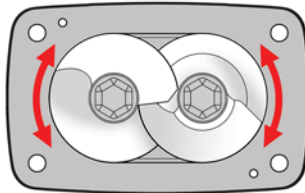

SHAFT ROTATION:
BI-DIRECTIONAL
evenly distributed clearance

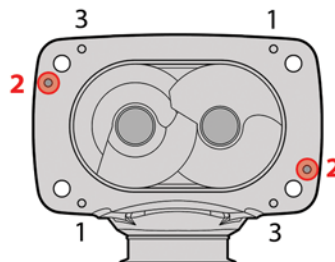

PIN CONFIGURATION:
2
evenly distributed clearance

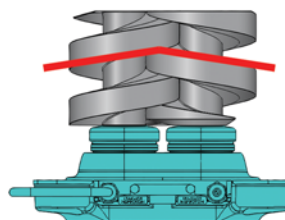

SPINDLE
ARRANGEMENT:
A

5.6 Oils, Grease & Lubrication Recommended

Lubricating Bearings and Gear Wheels

There are a few options for gear wheel lubrication in the Pump / Bearing Housing of the **ViscoTwin 104 G10**:

Polyglycol based (can absorb up to 3% water)

- Klubersynth

Polyalphaolefin based (cannot absorb water)

- Jax-68
- Castrol Optileb
- Lubriplate SFGO Ultra 220

As a general rule, thinner oil is more frequently used in colder areas, and thicker oil is use in warmer areas. A higher number next to the oil indicates a thicker oil, while a lower number indicates a thinner oil.

150 = thicker
68 = thinner

Jax-68 is used very commonly in the United States of America, where **Processtec** is located.

VT-Diagramm

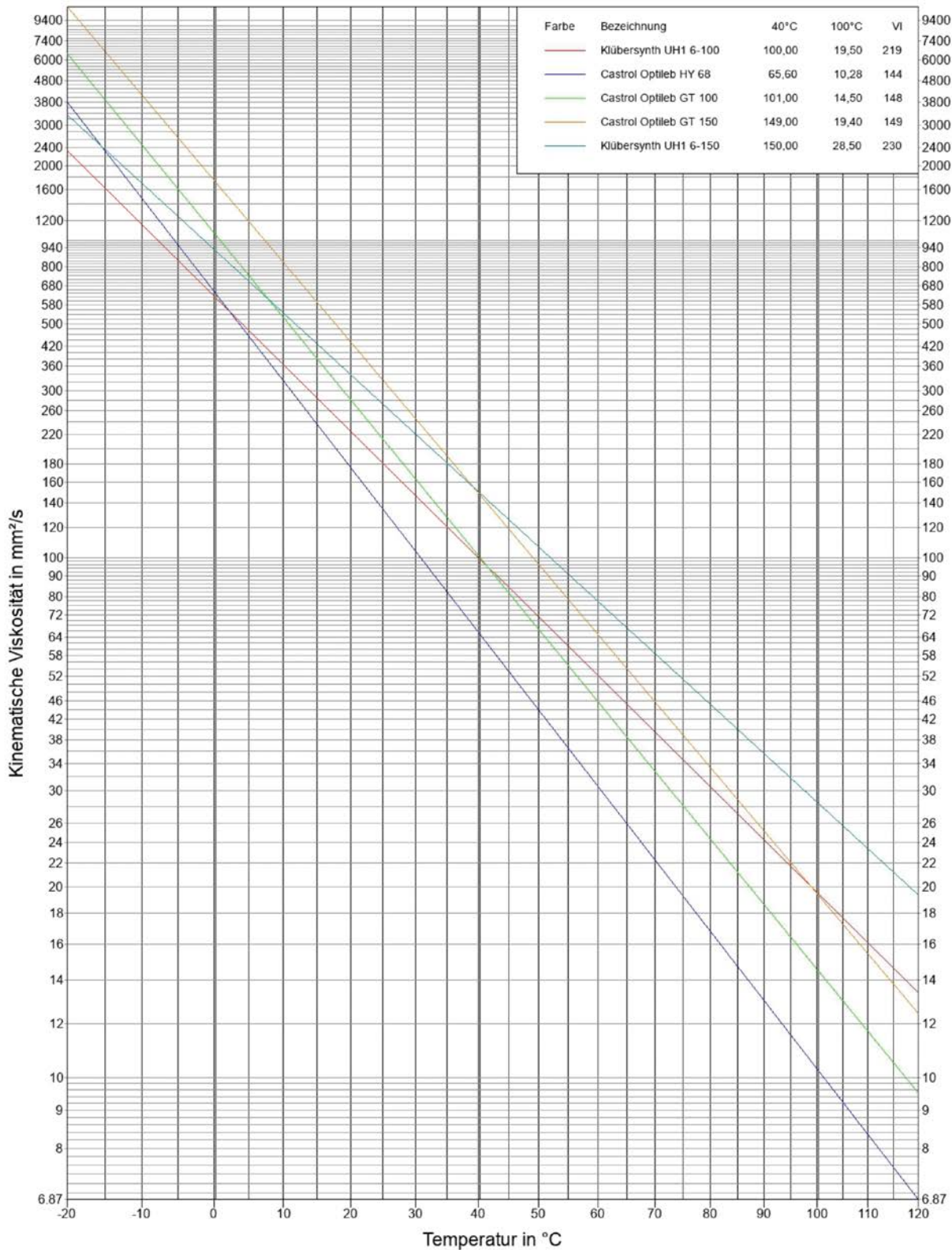

5.7 Oil Testing Kit (with Form)

Processtec offers an Oil Testing Kit (Sample Jar) to have your Used Oil mailed out to be analyzed.

Oil Testing Kit (Form and Sample Jar)				--
Part #	Material	Size	Specification	
23580		--		
<p>NOTES: Call <i>Processtec</i> for more information.</p>				

Also available from **Processtec** is an Oil Testing Tool (made by SKF). This tool gives you the ability to do a detailed analysis of your pump oil, just by first placing a drop of clean oil and capturing a reading, and then placing a drop of used oil and comparing the difference between the two.

Oil Testing Tool (SKF)				--
Part #	Material	Size	Specification	
--		--	by SKF	
<p>NOTES: Call <i>Processtec</i> for more information.</p>				

6. GEEK'S CORNER

6.1 Oil Cooler with Oil Filter

In case very hot product is pumped, the heat can sometimes penetrate through the shaft to the needle bearings, and shaft seals (Pos. 2322). It is strongly recommended to install an oil cooler to maintain the oil temperature at the needle bearings at max 212° F (100° C).

Processtec's customized oil cooling system for ViscoTwin pumps is shown below.

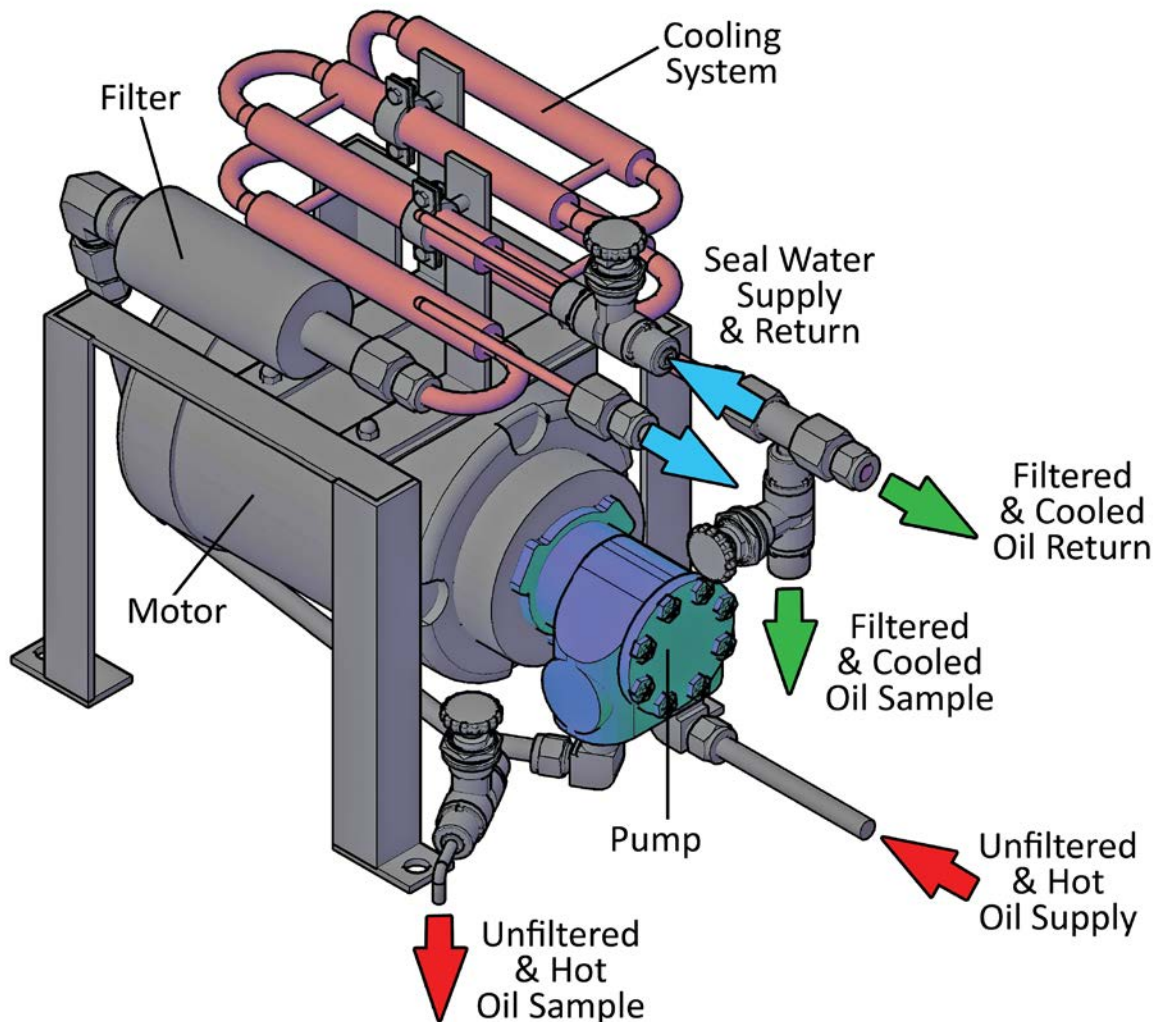

6.2 Vibration Sensor with Oil Temperature Sensors

Processtec, along with GEPA Engineering, is testing a customized solution to accurately sense the harmonics of **ViscoTwin** pumps. This will allow the pump's bearing to be monitored continuously.

Especially for high pressure applications where high axial forces dramatically limit the bearing lifespan, vibration monitoring will prevent unexpected downtime with planable preventative maintenance, making **ViscoTwin** high pressure pump setups a highly sustainable solution.

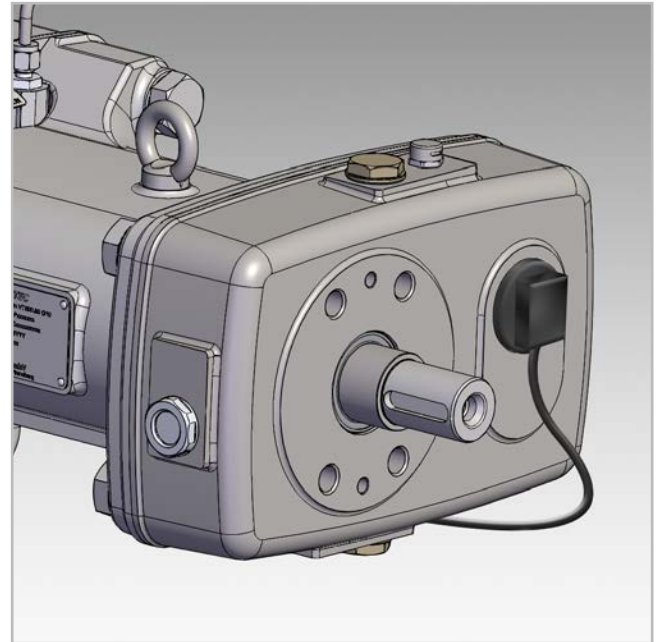

6.3 Quench Design for Recirculating Fluids in Mechanical Seals

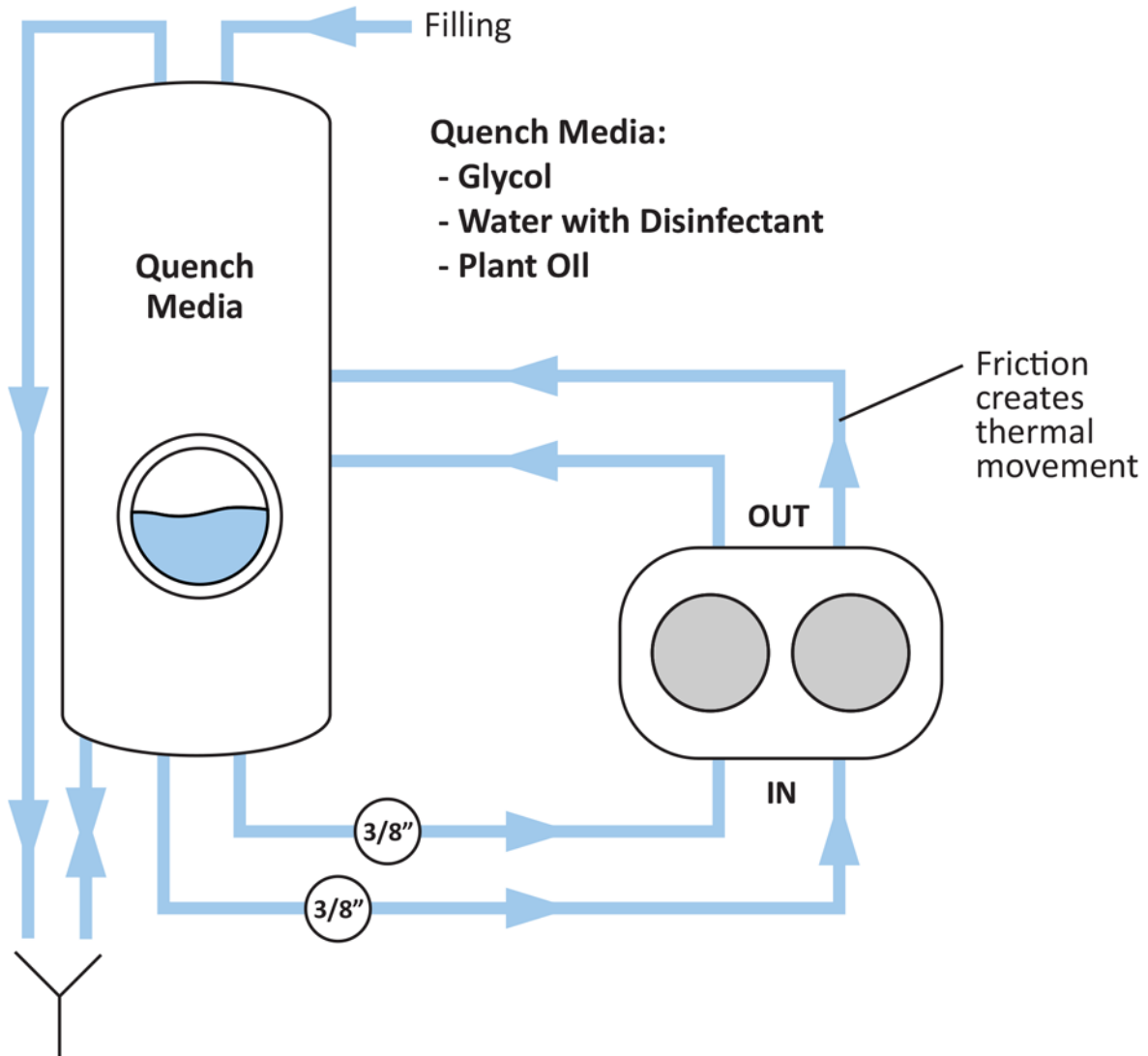

6.4 Maximizing Bearing Lifespan

The Importance of Bearing Lifespan

Bearings are a key element to sustained pump operation. Throughout the lifespan of any pump, the bearings experience the majority of operation based wear and tear and are often the first point of failure. Without regular bearing maintenance, mechanical failure becomes inevitable. This leads to complications and consequences to further pump operation as well as significant losses in production from maintenance downtime. Bearing lifespan is an important tool in maximizing lifespan across the system as well as avoiding costly repairs.

Bearing Types Across ViscoTwin Pump Line

Pump	Ball Bearing (SKF)	Needle Bearing (FAG / KOYO)	Applicable Area of the Top of the Spindle	Applicable Area of the Front of the Spindle
VT-70	7305 BECBM	NKJ 40/30	0.0037 m ²	0.0050 m ²
VT-104	7207 BECBM	NA 6910	0.0060 m ²	0.0079 m ²
VT-130	7209 BECBM	NA 6912	0.0113 m ²	0.0133 m ²

Table 1: ViscoTwin Pump Bearing Configuration

The **Processtec** line of **ViscoTwin G10** pumps are equipped with two different types of bearings in varying configurations, each with their own specifications. All bearings used in **ViscoTwin** pumps are produced by SKF high-performance bearings with the exception of the needle bearing used in the Model VT-70, produced by KOYO.

Measured Impact of Each Variable

Introduction

The following analysis was performed on a standard 7207 BECBY bearing in a test by SKF high-performance bearings. The constants for the models are as follows:

Pump: VT-104

Direction: Front in / Top Out

Exit Pressure: 25 bar

Supply Pressure: 2 bar

Radial Load: 3 kN

Total Axial Load: 14 kN

r/min: 1500

Number of bearings in Tandem: 2 sets of 2 bearings in tandem

Axial Load per Bearing: 7 kN

Operating Temperature: 80° C

Nc specifications: Slight-typical contamination

Lubrication Viscosity: 100 mm²/s @ 40° C and 40 mm²/s @ 100° C

Effective Variables in Bearing Lifespan

Mounting Arrangement

Processtec installs bearings in tandem to allow bearings to share the load evenly and reduce stress. This drastically extends the lifespan of bearings due to the force reduction by a factor of 'n', where 'n' is the number of bearings mounted in tandem with the force exerted on the bearing in both radial and axial dimensions.

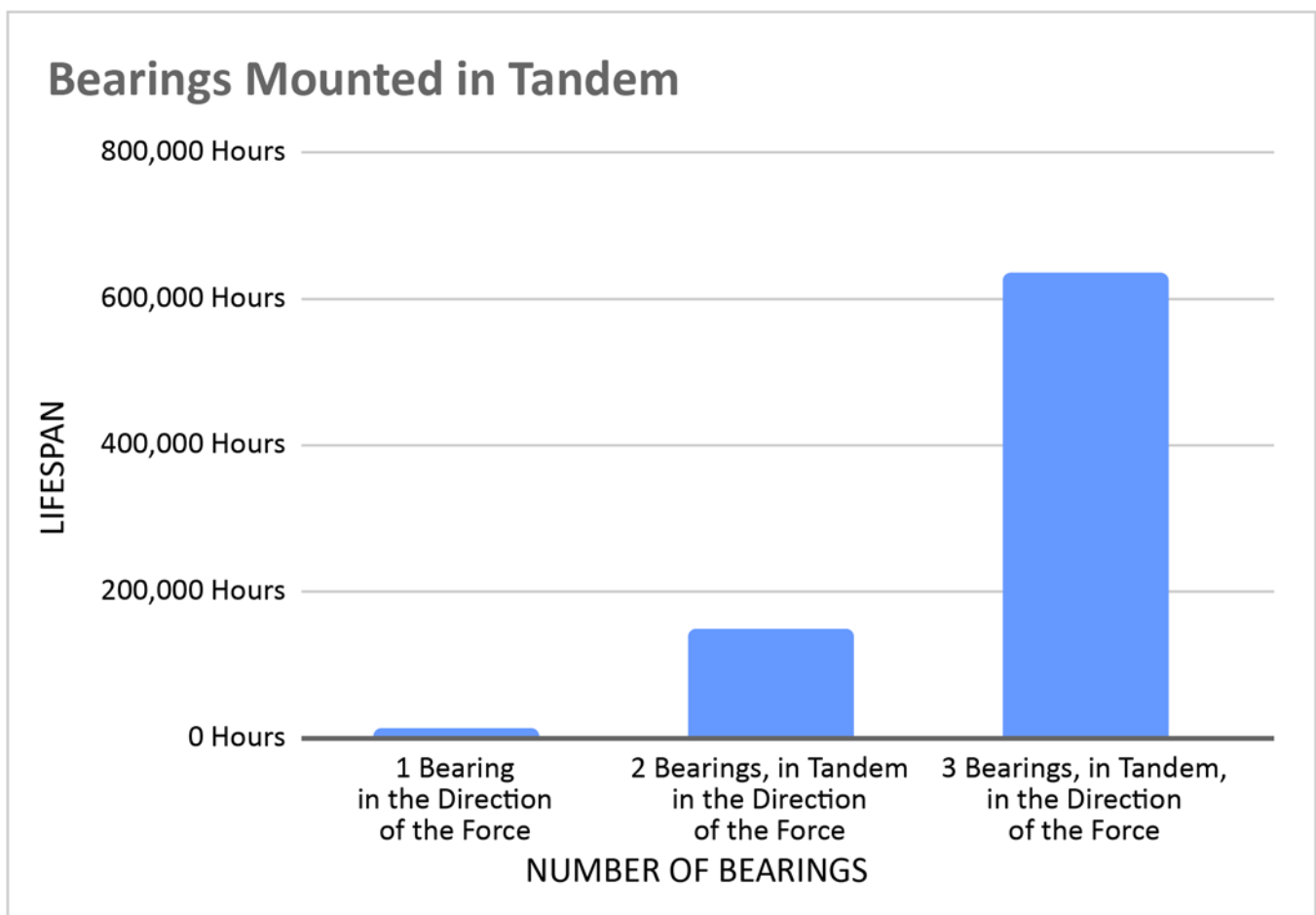

Oil Cleanliness

During pump operation, friction tears particles from the exterior of the balls and rollers. These particles then accumulate in the oil, exponentially increasing the wear on the bearings as well as increasing the bearing operating temperature due to friction. For these reasons, it is vital to check the bearing oil regularly for the particulates and replace the oil as necessary. All **ViscoTwin** pumps come standard with two magnetic plugs to help collect and trap particulates, keeping the oil cleaner for longer.

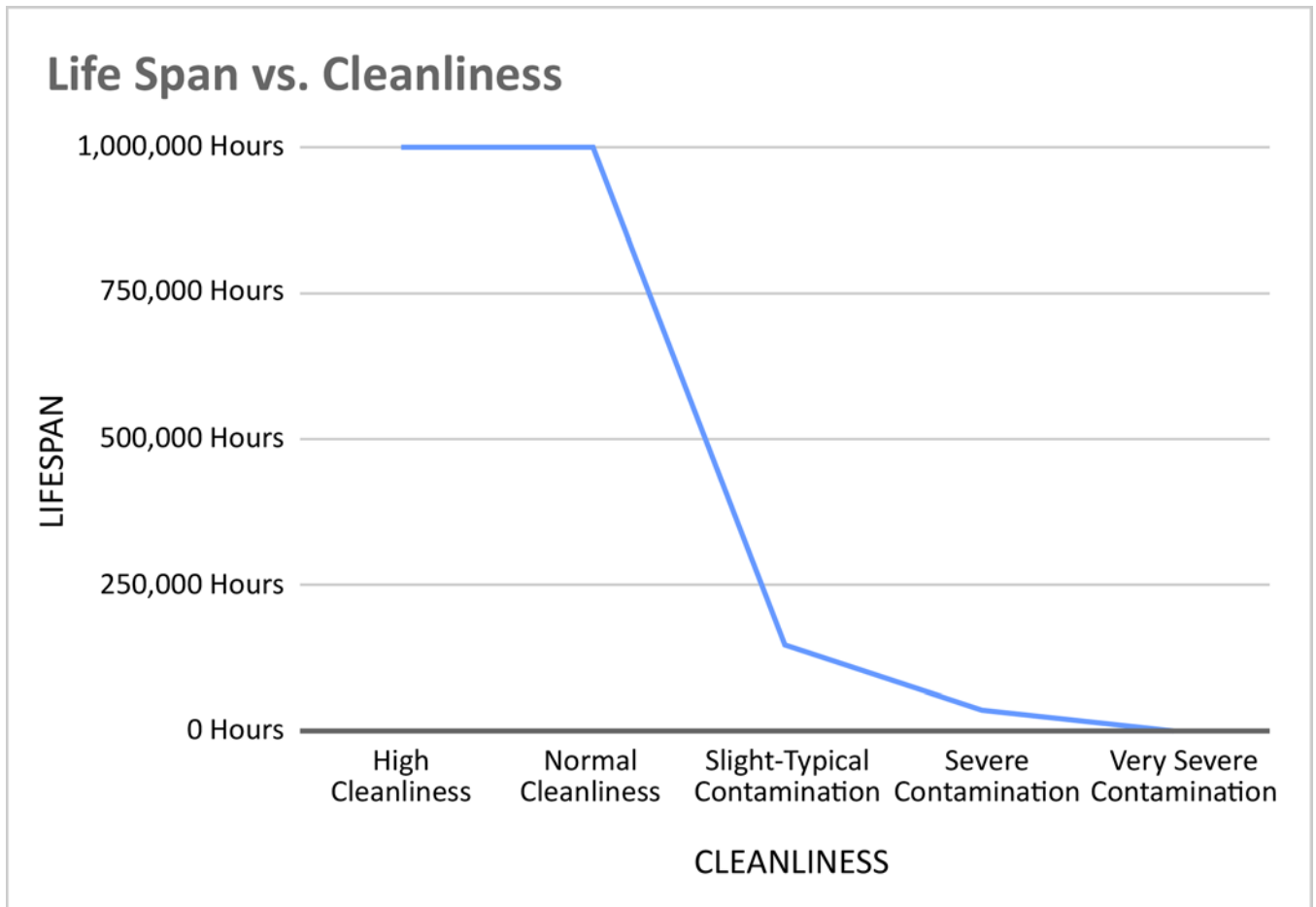

Bearing Quality

If a bearing fails to meet industry standards, it will be unable to distribute force on the rollers/balls evenly. Failing to meet these standards will not only create metal particles in the oil and increase operating temperature, it could also imbalance the pump shaft. It is essential that the pumps only use high-quality bearings with tight tolerances.

To ensure your bearing is functioning correctly, check the following things:

- All roller balls are present in the ball bearing
- When rotated, all rollerballs make contact with both surfaces and roll and don't slip
- Make sure there is very little play when holding the exterior ring and applying force to the side with the larger interior ring
- Look for perfectly round roller balls. Any discoloration and dents can be a sign of a bad bearing

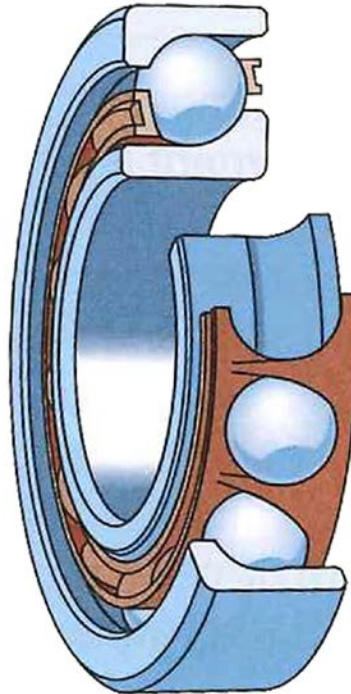

Oil Operating Temperature

As the bearings change temperature, they both expand and experience thermal shock, both of which serve to increase bearing wear and tear. With the rise in operating temperature, the oil also begins to thin, providing less lubrication for the bearings.

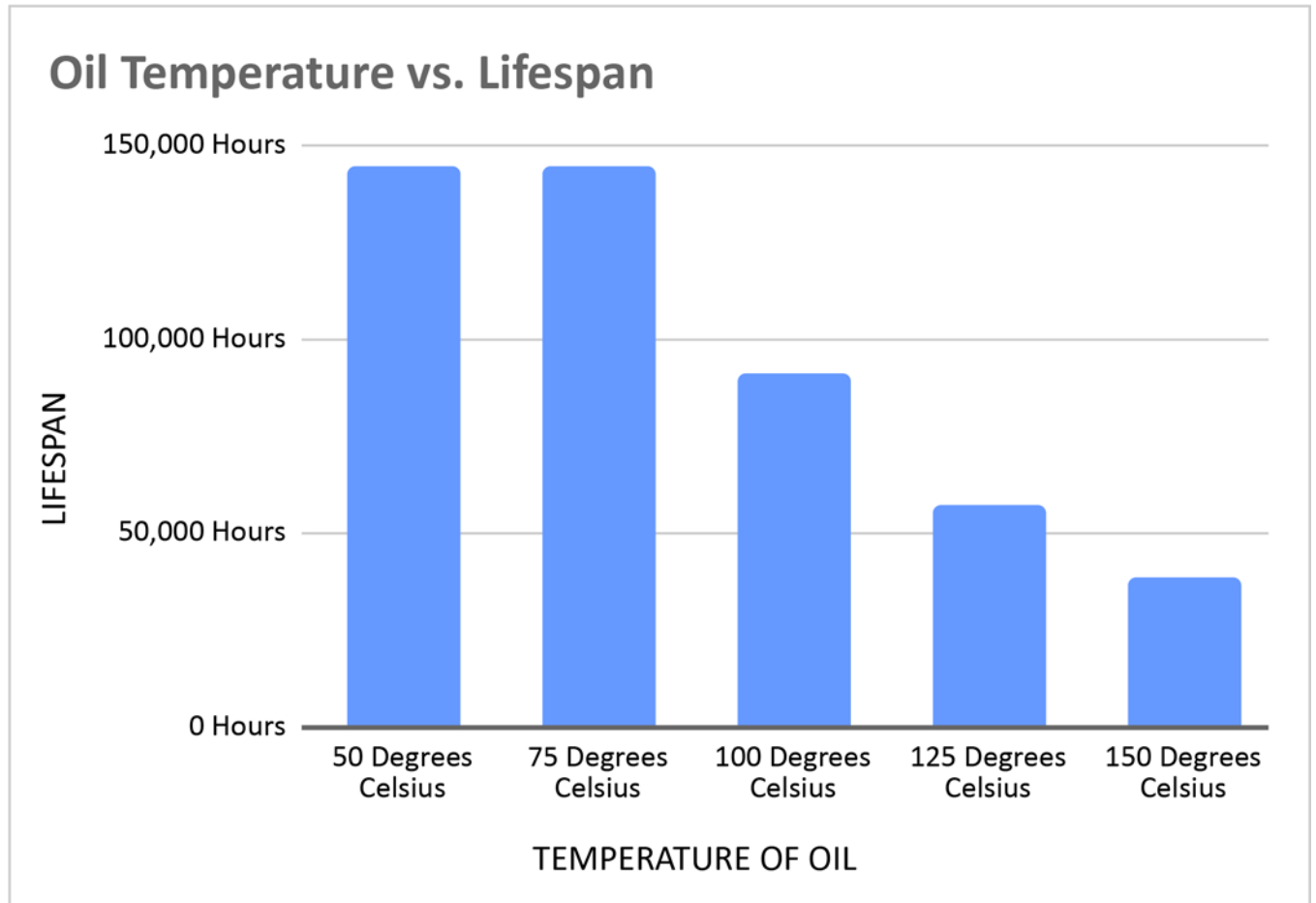

Oil Thickness

High viscosity oils are more effective at lubricating bearings. They reduce friction between the balls and the outer casing, thus reducing both heat generation and damage caused by parts contacting.

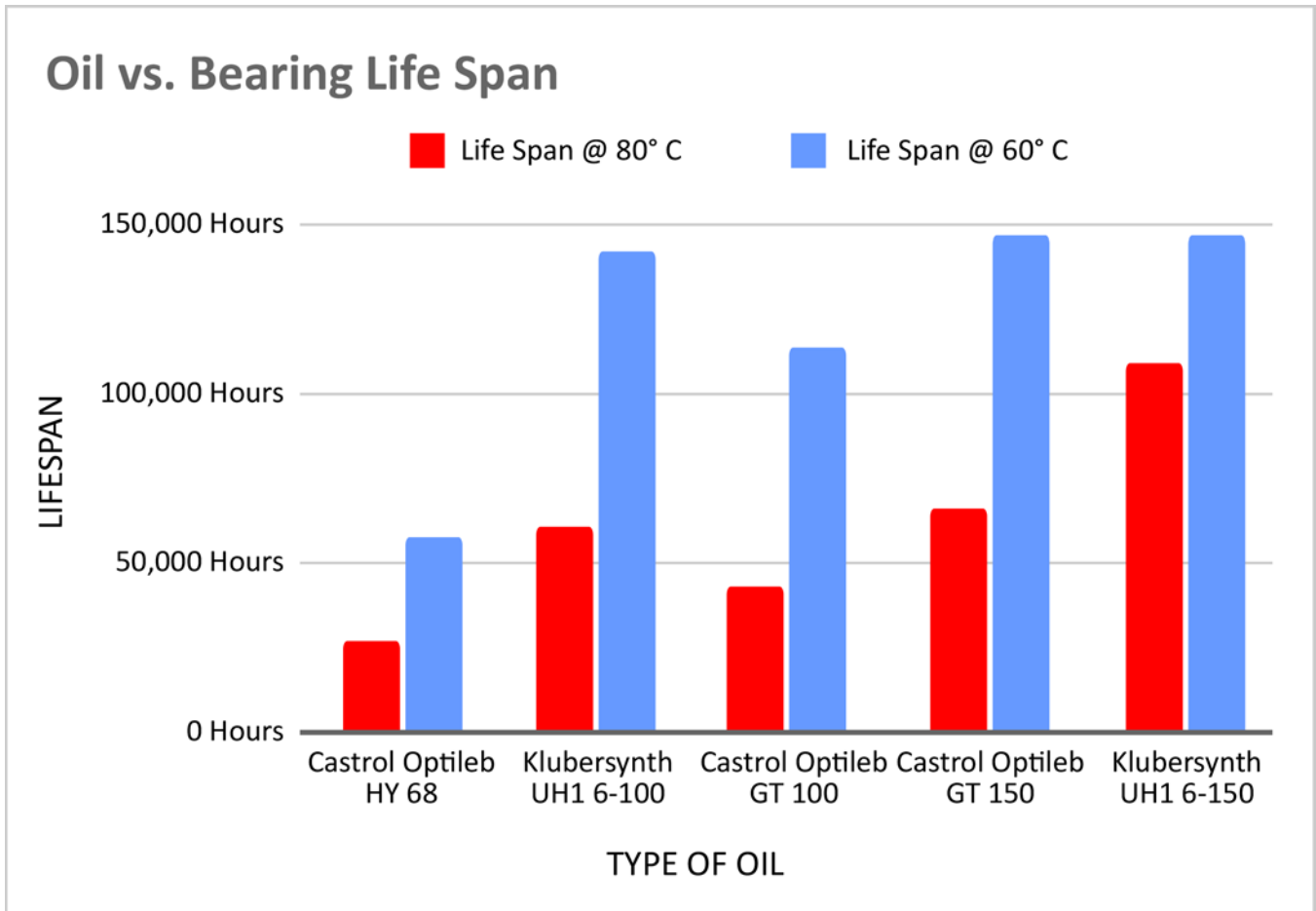

Rotation Per Minute

Increasing the RPM's forces each bearing to travel farther and faster over time, increasing the heat produced and damage each bearing will accumulate versus the same bearings being used at lower RPM's over the same time. Furthermore, the RPM's limits the effectiveness of more viscous oils due to the increased resistance from moving through thick oil, outweighing the benefits of more viscous oil.

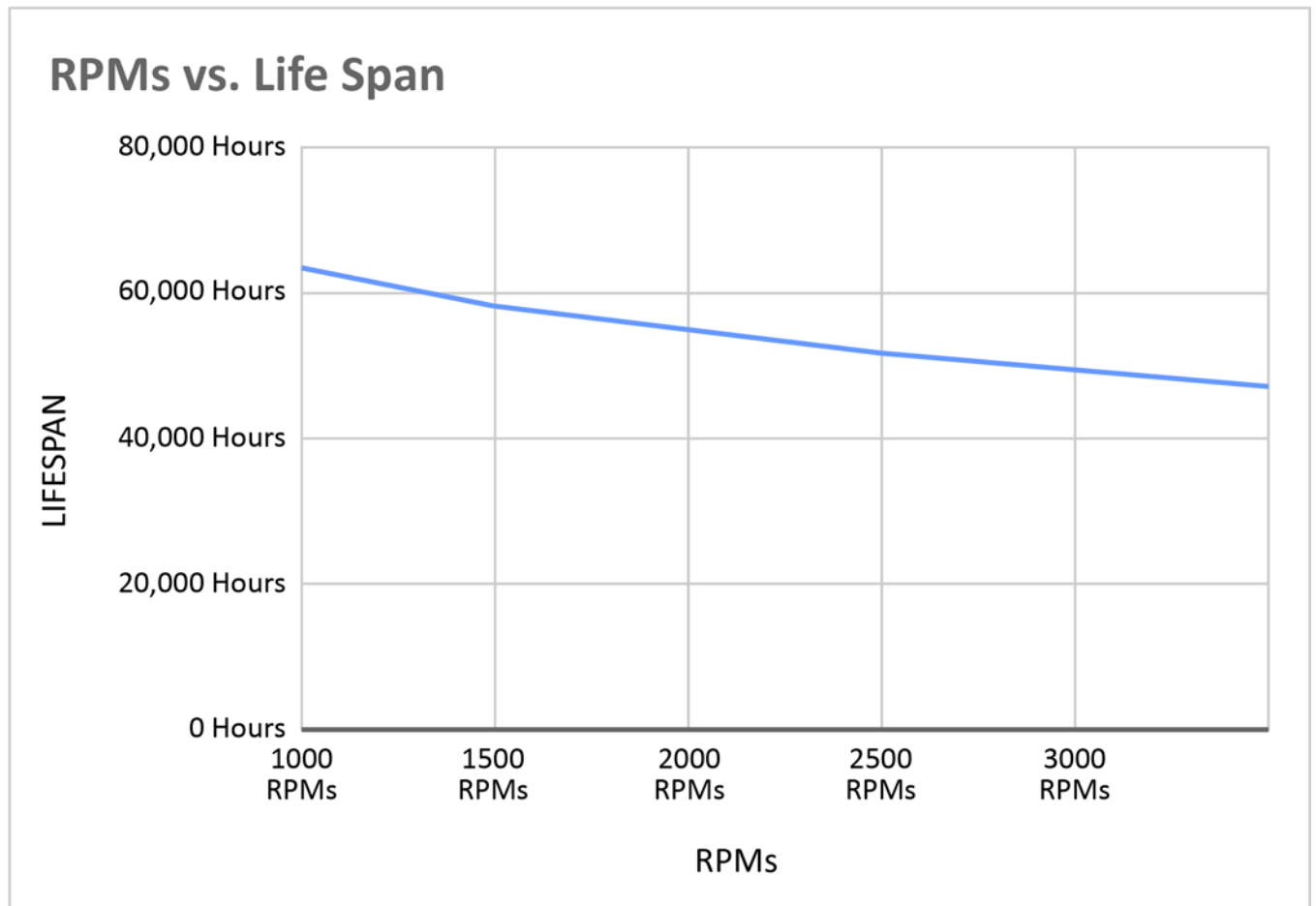

Reference Page

Pump Diagram HF(Housing In, Face Out)

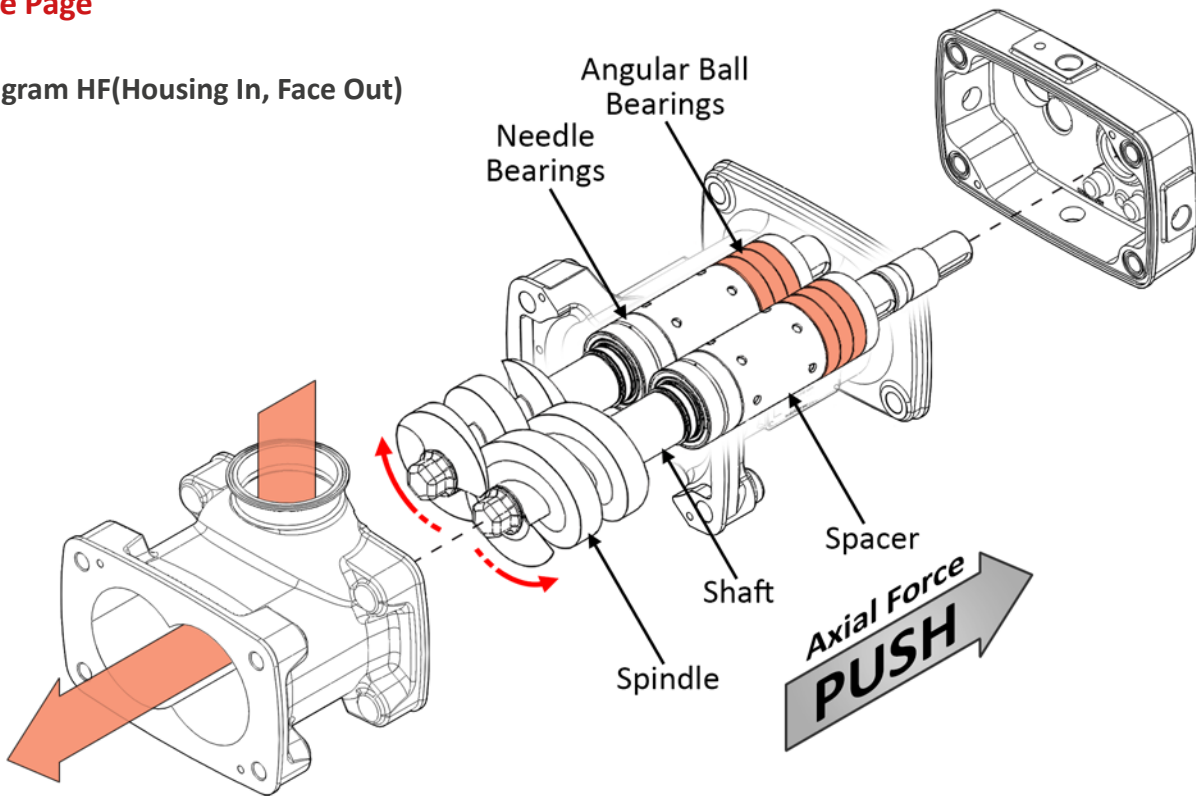

Pump Diagram FH (Face In, Housing Out)

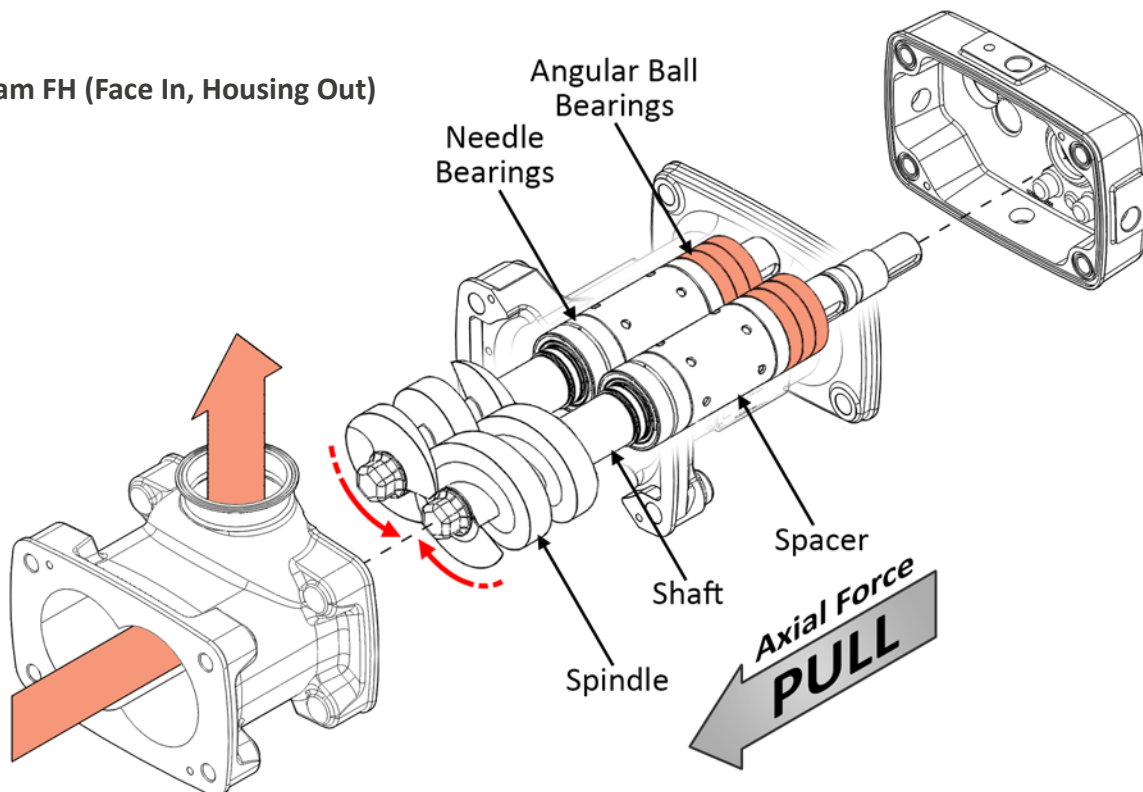

Bearing Arrangement

The three bearings shown below (highlighted in red) are in tandem alignment when they share the Axial Force three ways. A single bearing is supporting the opposite direction.

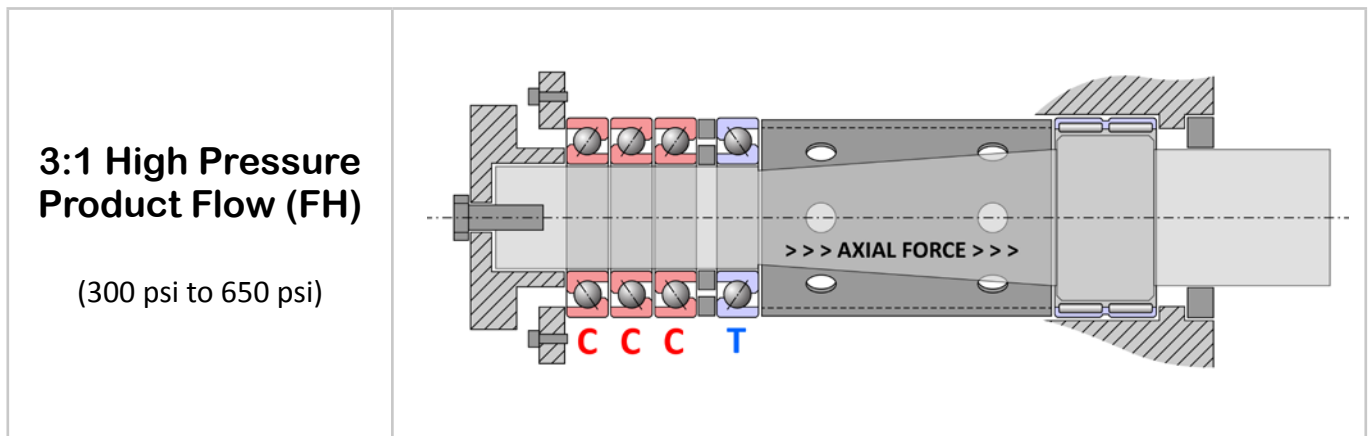
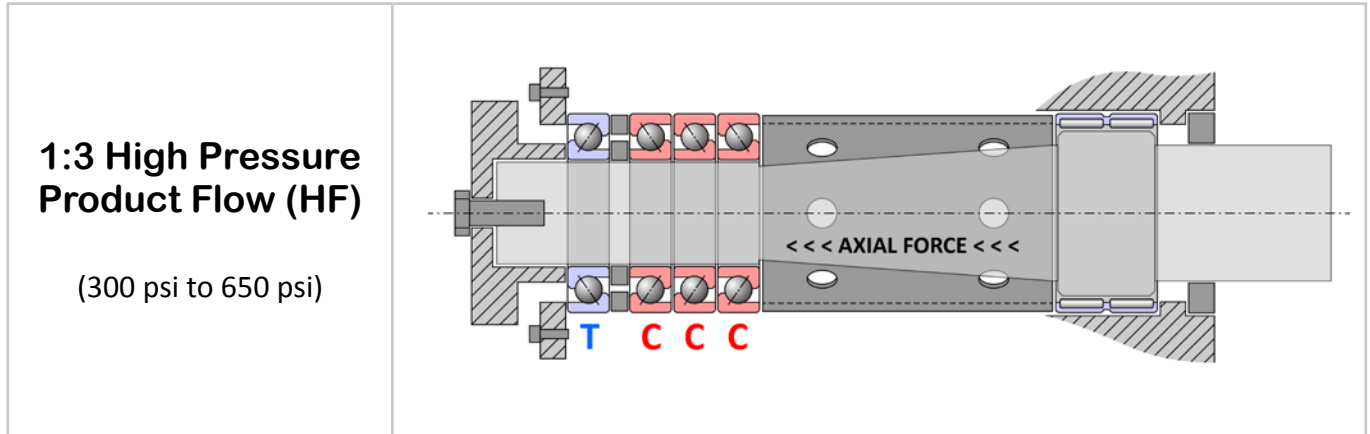

Axial Load Calculation Method

Axial load is the force acting parallel to the axis of rotation along the shaft. The axial load can be found by using the following equation:

$$F_a = (P_o * A_o) - (P_i * A_i)$$

Where P_o is pressure out of the pump, P_i is the pressure into the pump. A_o is the area of the spindle facing the direction the product exists. A_i is the surface area of the part of the spindle facing where the product enters the pump. F_a is the axial load.

Area Out	Area In	Pressure Out	Pressure In	Force Out	Force In	Axial Force	Per Bearing
A_o	A_i	P_o	P_i	$A_o * P_o$	$A_i * P_i$	$(A_o * P_o) - (A_i * P_i)$	F_a/n
0.0060 m ²	0.0079 m ²	2500.00 kn/m ²	1000.00 kn/m ²	15.11 kn	7.85 kn	7.26 kn	3.63 k n

Table 2: An example of **ViscoTwin** 104 Front In /Top Out with two bearings in tandem.

6.5 Equipment Commissioning Protocol

Equipment Commission Protocol

Date: _____ Job # _____

Serial #	Model #
----------	---------

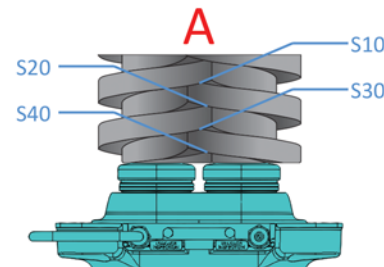
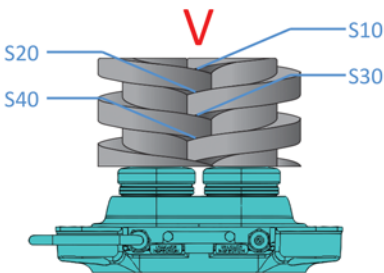
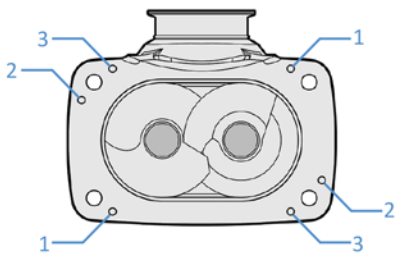
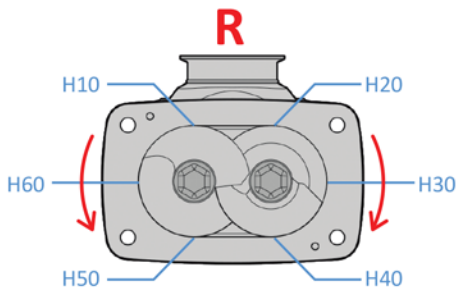
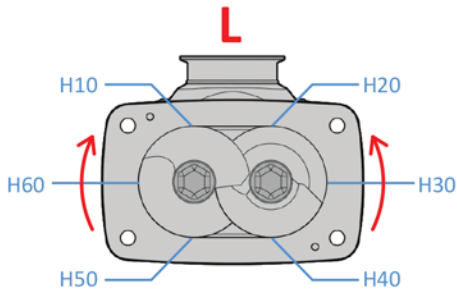

ROTATION DIRECTION

RIGHT	LEFT
-------	------

FRONT CLEARANCES

H10	mm
H20	mm
H30	mm
H40	mm
H50	mm
H60	mm

PIN ARRANGEMENT

Position #

PUMP HOUSING STYLE

G8	G9
G10	Mach.

HARDENED SPINDLES

Yes	No
-----	----

SPINDLE ARRANGEMENT

'V'	'A'
-----	-----

SPINDLE CLEARANCES

S10	mm
S20	mm
S30	mm
S40	mm

(1 inch = 1mm / 25.4)

Comments:

PICTURES TAKEN

YES	NO
-----	----

LABELS ATTACHED

YES	NO
-----	----

SEAL MAKE & TYPE

ANGA	
HUHNSEAL	
Single Acting	
Double Acting	
FKM	
EPDM	
SIC/SIC	
TC/TCKNE	

BEARING ARRANGEMENT

