



PROCESSTEC

GET TOMORROW'S TECHNOLOGY TODAY

ViscoTwin

R+W Disengaging Coupler



Address: 9938 West Legacy Ave | Visalia, CA 93291 | Phone: +1 (559) 429-4227
Fax: +1 (559) 429-4228 | Email: info@processtec.com | <http://processtec.com>

1. INTRODUCTION 1

- 1.1 Re-engaging the Coupler..... 1**
 - 1.1.1 Purpose 1**
 - 1.1.1 Important Note for the PLC Programmer..... 1**

2. R+W DISENGAGING COUPLER..... 3

- 2.1 Re-engaging the Coupler..... 3**
- 2.1 Re-engaging the Coupler Movie..... 10**

3. TECHNICAL SPECS..... 11

- 3.1 VT130 Explosion Drawing 11**
- 3.2 VT130 Torque Chart..... 12**
- 3.3 Frame #4 Explosion Drawing 13**

1. INTRODUCTION

1.1 Re-engaging the Coupler

1.1.1 Purpose

Torque limiting Disengaging Couplings protect the primary equipment that is connected to the motor, in this case the **ViscoTwin** pump head.

In case foreign matter enters the pump and blocks the spindles, the rotating mass of the motor creates too much torsional force to the drive shaft and the bearings in case it's stopped immediately. This can result in critical components of the pumphead being destroyed and will then require costly repairs.

A correctly sized and installed Disengaging Coupling (torque limiter) will protect the pumphead. Removing the blockage in the pump head, checking the clearance of the spindles (Impellers), and re-engaging the coupler will bring the pump back in operation within 30 minutes, saving the need for repair and excessive downtime cost.

1.1.1 Important Note for the PLC Programmer

NOTE: Once the coupler is disengaged, the motor needs to be shut down immediately! The PLC software needs to be setup to detect the decrease in amperage sent to the motor in order to shut it down automatically. Running the disengaged coupler for excessive time (more than 1 minute) will overheat the internal bearing and destroy it.

We could install a proximity switch to detect the coupler being dis-engaged in case the amperage monitoring would not be practical.

2. R+W DISENGAGING COUPLER

2.1 Re-engaging the Coupler

STEP 1)

Disconnect the Pump Housing Bolts (Pos. 1016) from the Pump Housing (Pos. 2530).

Using the Frame #4 Gear Console underneath the Lantern (Pos. 3000), slide the Pump/Lantern/Motor all the way back until the Bearing Housing Sliders reach the Stop Brackets on Frame #4.

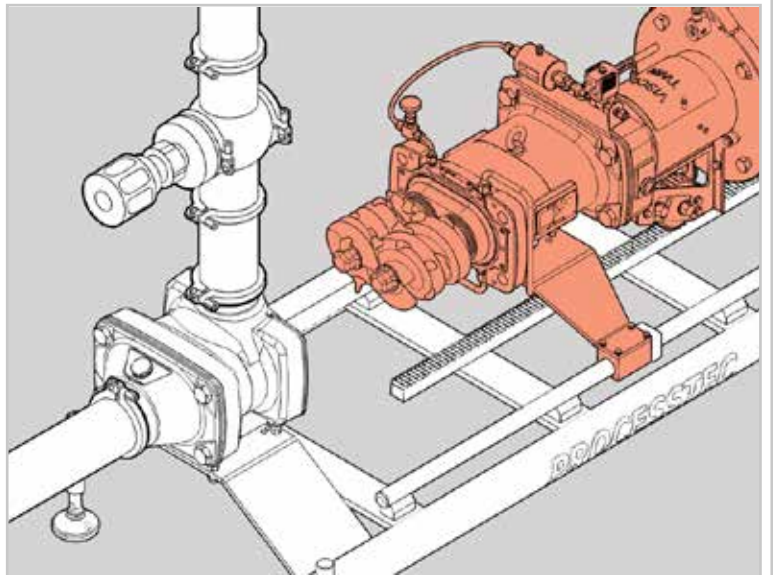
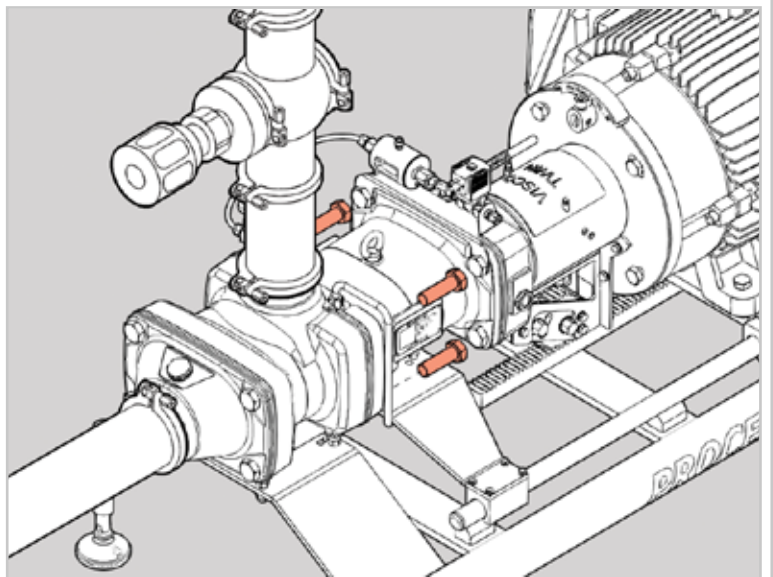

STEP 2)

Clean and inspect the Spindles (Pos. 2200 & 2201) for foreign matter and check for Spindle deformation. Determine the cause of the blockage.

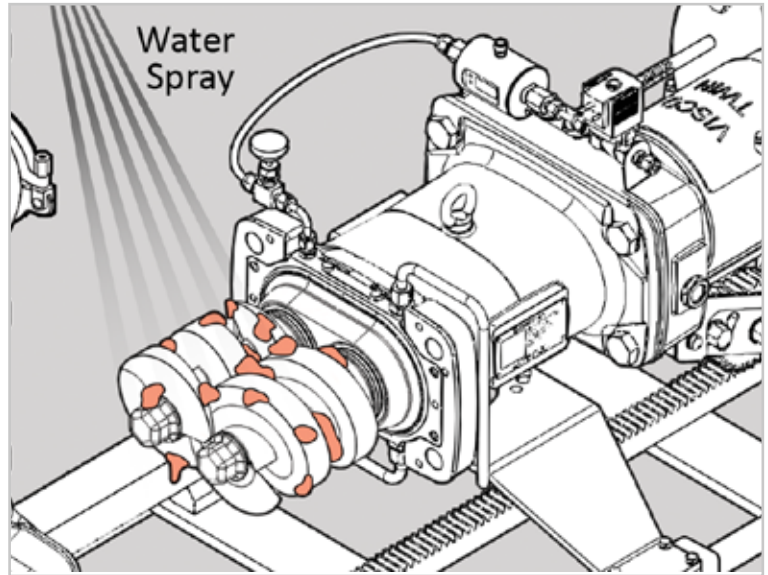

STEP 3)

IMPORTANT: Wearing a pair of Safety Gloves for this step is required.

Grab both Spindles (Pos. 2200 & Pos. 2201) and check for full 360 degree rotation, in both directions. Ensure that there is no touching or rubbing between the Spindles. If rubbing exists, you will need to either remove the high points with light sanding, or re-gap the Spindles.

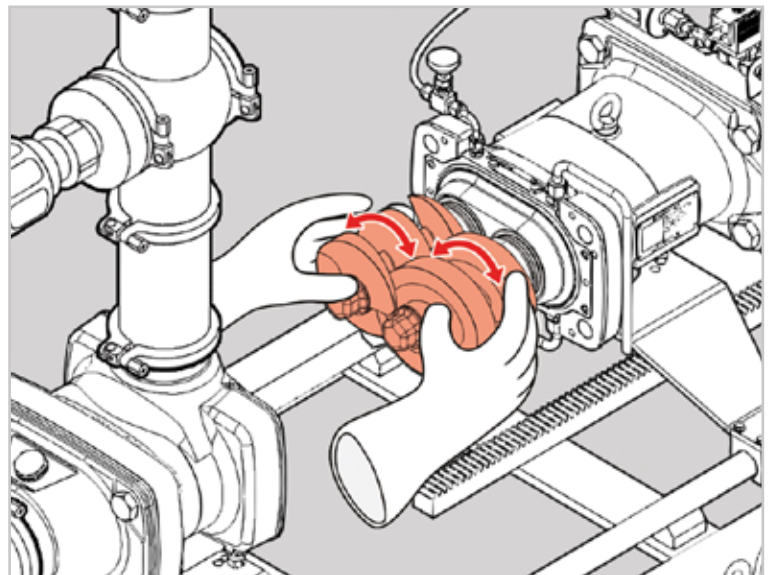

STEP 4)

Remove TWO (2) Lantern Cap Nuts (Pos. 3002) and then remove the Lantern Safety Shield (Pos. 3001) from the Lantern (Pos. 3000).

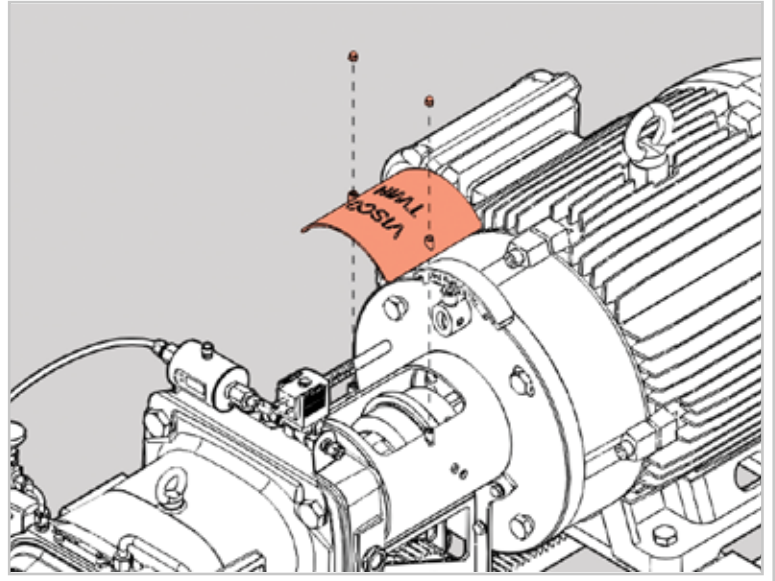

STEP 5)

Align the 3 yellow dots on the Pump Coupler (Pos. 2247) and the Motor Coupler (Pos. 2248) by rotating the Motor Coupler until all THREE (3) yellow dots are perfectly aligned.

The Coupler cannot be re-engaged if these dots are not first aligned.

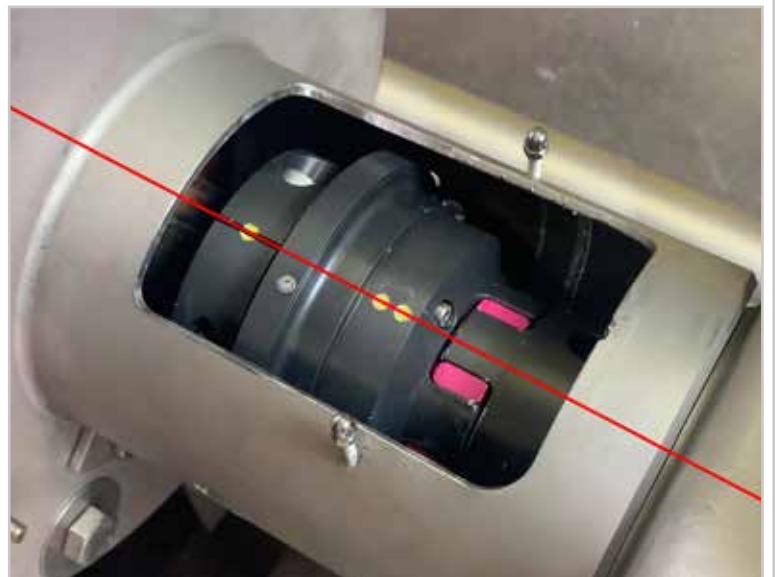

STEP 6)

Remove the TWO (2) Breakaway Coupler Levers (Pos. 3030) that are threaded on the side of the Lantern (Pos. 3000). These tools will be used to Re-engage the R+W Coupler.

Arrange the flat surfaces of the tips so that they will be able to rest against the backside of the Motor Hub Outer Ring.

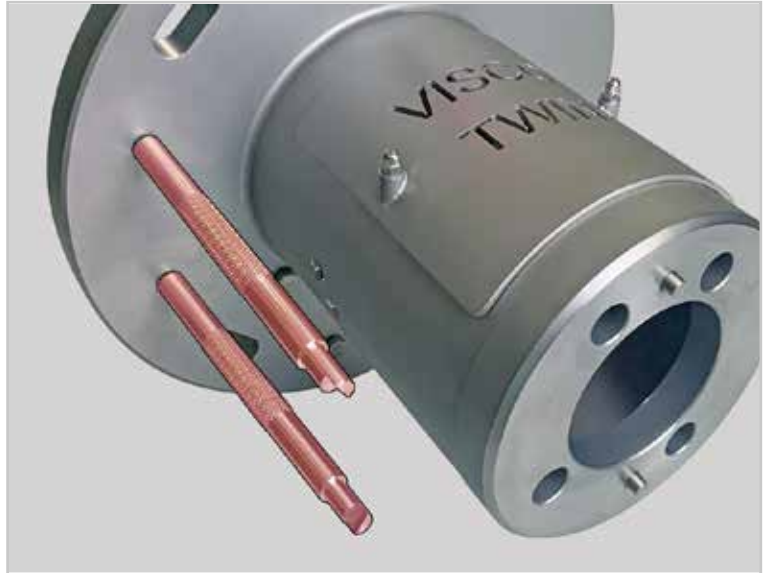

STEP 7)

Insert both Breakaway Coupler Levers (Pos. 3030) into the small holes on the sides of the Lantern (Pos. 3000) that are closest to the Motor (Pos. 3003), with the flat surfaces of the tips touching the Motor Hub Outer Ring.

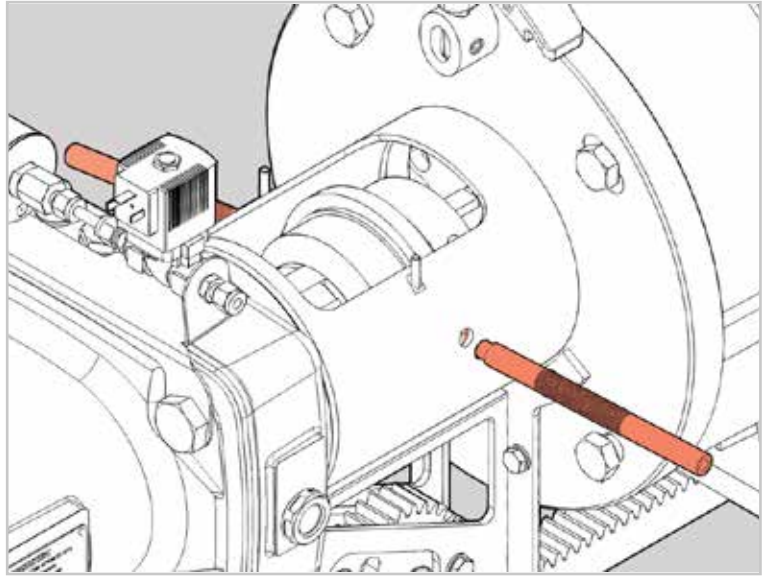

STEP 8)

Using leverage on both tools inserted into the Lantern openings, move the tools towards the Lantern Flange, prying the Motor Hub Outer Ring (Pos. 2248) towards the Pump.

A "click" sound should be heard as you see the movement of the outer ring when the coupler has been properly re-engaged.

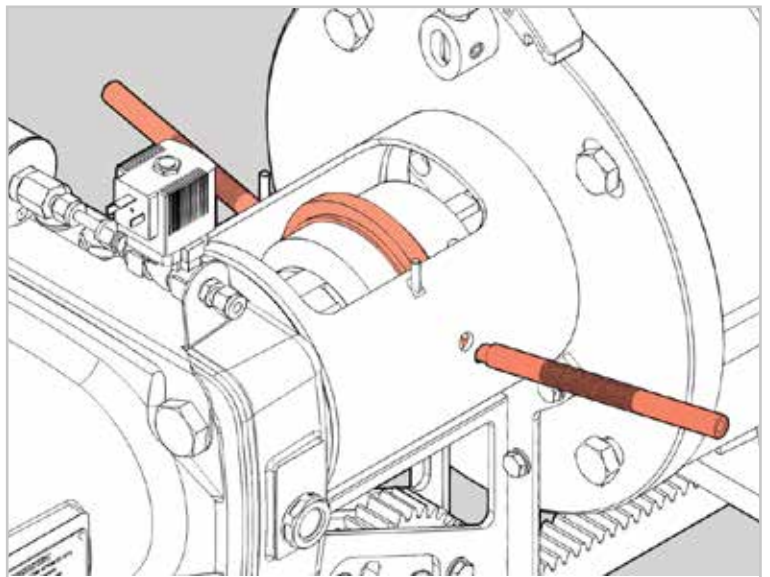

STEP 9)

Test for the complete re-engagement of the Coupler by turning one of the Shaft Spindle Bolts (Pos. 2180) with a wrench, and confirm that the Motor Hub (Pos. 2248) and Pump Hub (Pos. 2247) move together.

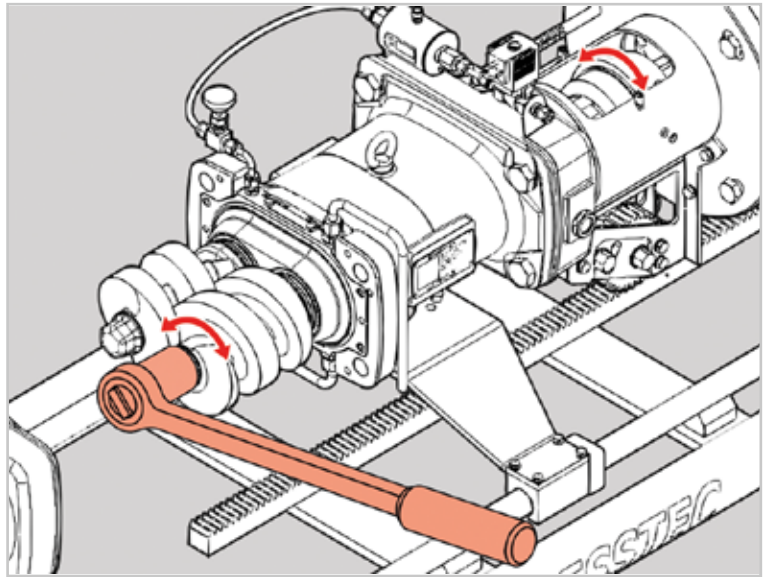

STEP 10)

Replace the Re-engagement Tools (Pos. 3030) onto the Lantern (Pos. 3000), reattach the Lantern Safety Shield (Pos. 3001) and then fix the Cap Nuts (Pos. 3002) in place.

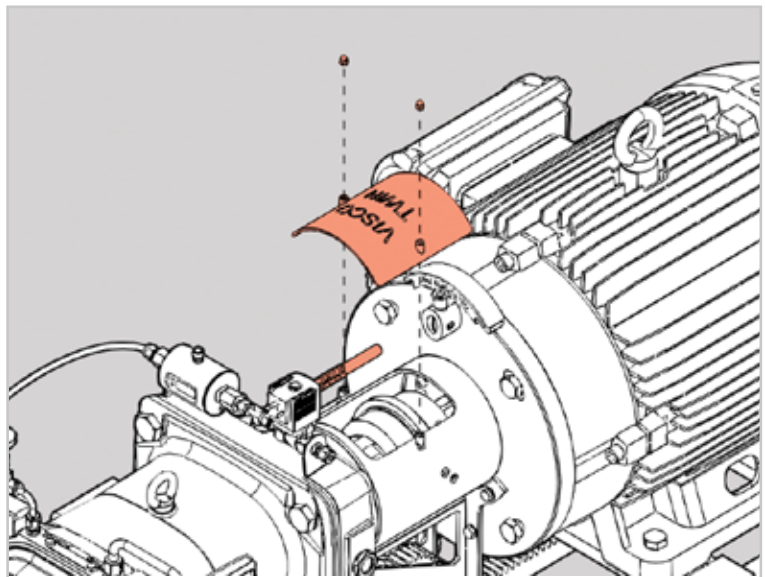

STEP 11)

Close the Pump by moving the Pump/ Lantern/Motor along the Frame #4 Track until the Spindles are fully inserted into the Pump Housing. Take care not to pinch the O-ring Seal (Pos. 1088) when closing the Pump.

When the Pump Housing (Pos. 2530) and Bearing Housing (Pos. 1001) are completely closed, you can reinstall the Pump Housing Bolts (Pos. 1016).

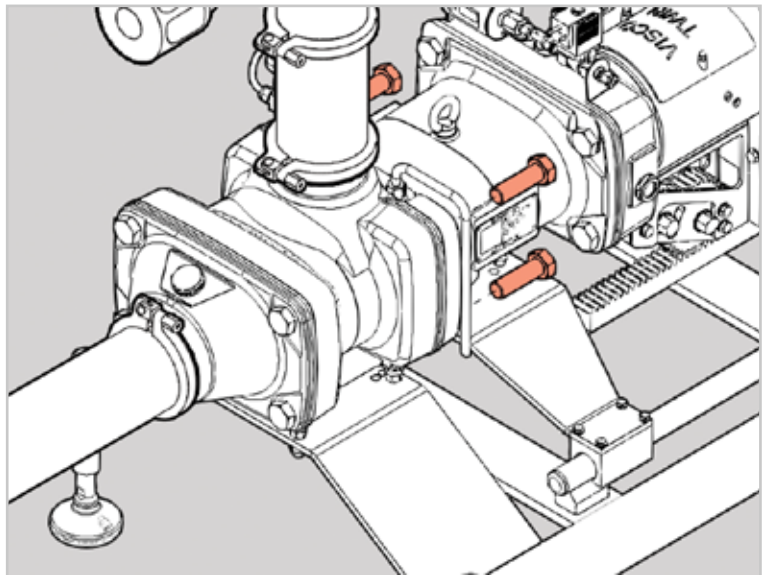
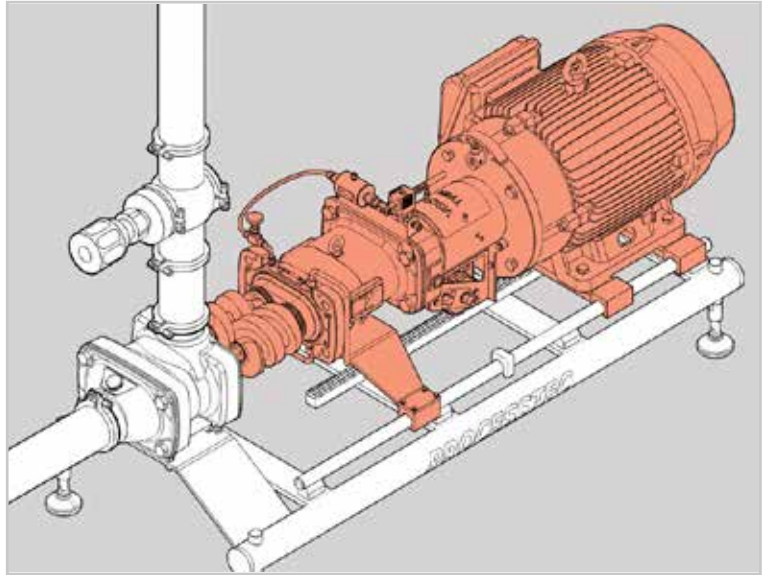

2.1 Re-engaging the Coupler Movie



A short movie has been created showing the process of Re-engaging the Motor Hub after it has become disengaged.

You can access this movie via the QR Code.

3. TECHNICAL SPECS

3.1 VT130 Explosion Drawing

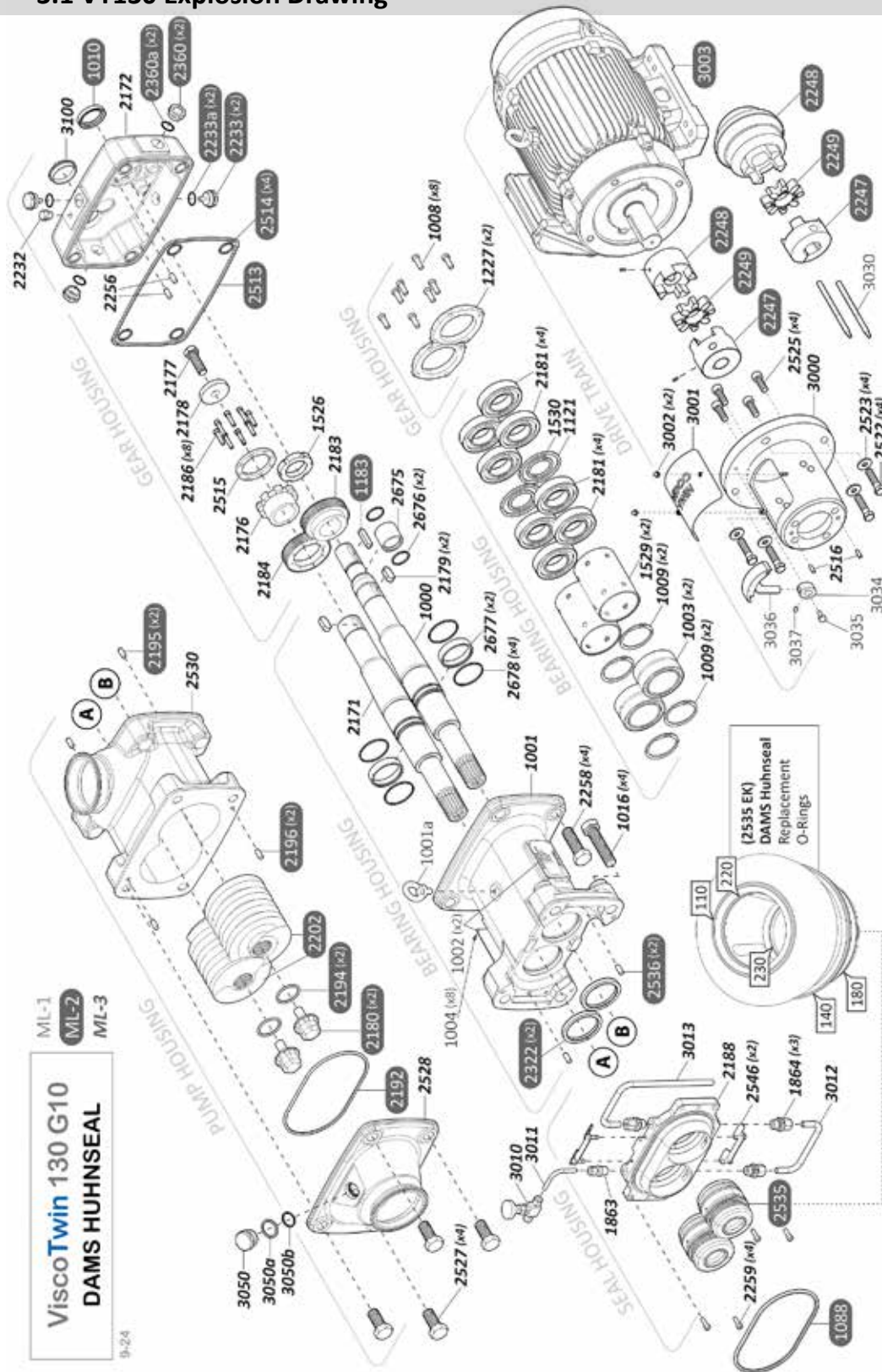

Tabloid Size
(11" x 17")

3.2 VT130 Torque Chart

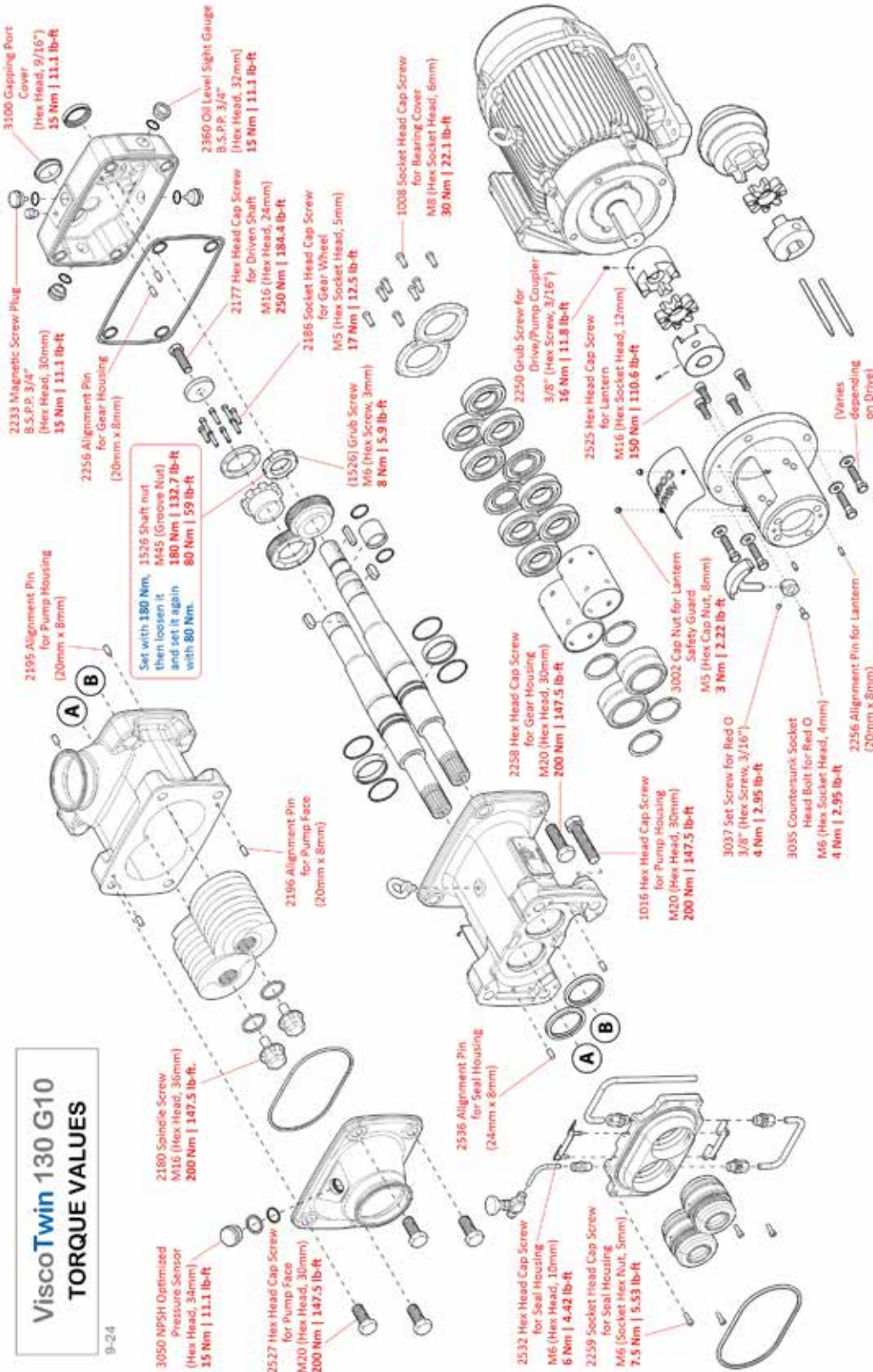

Tabloid Size
(11" x 17")

3.3 Frame #4 Explosion Drawing

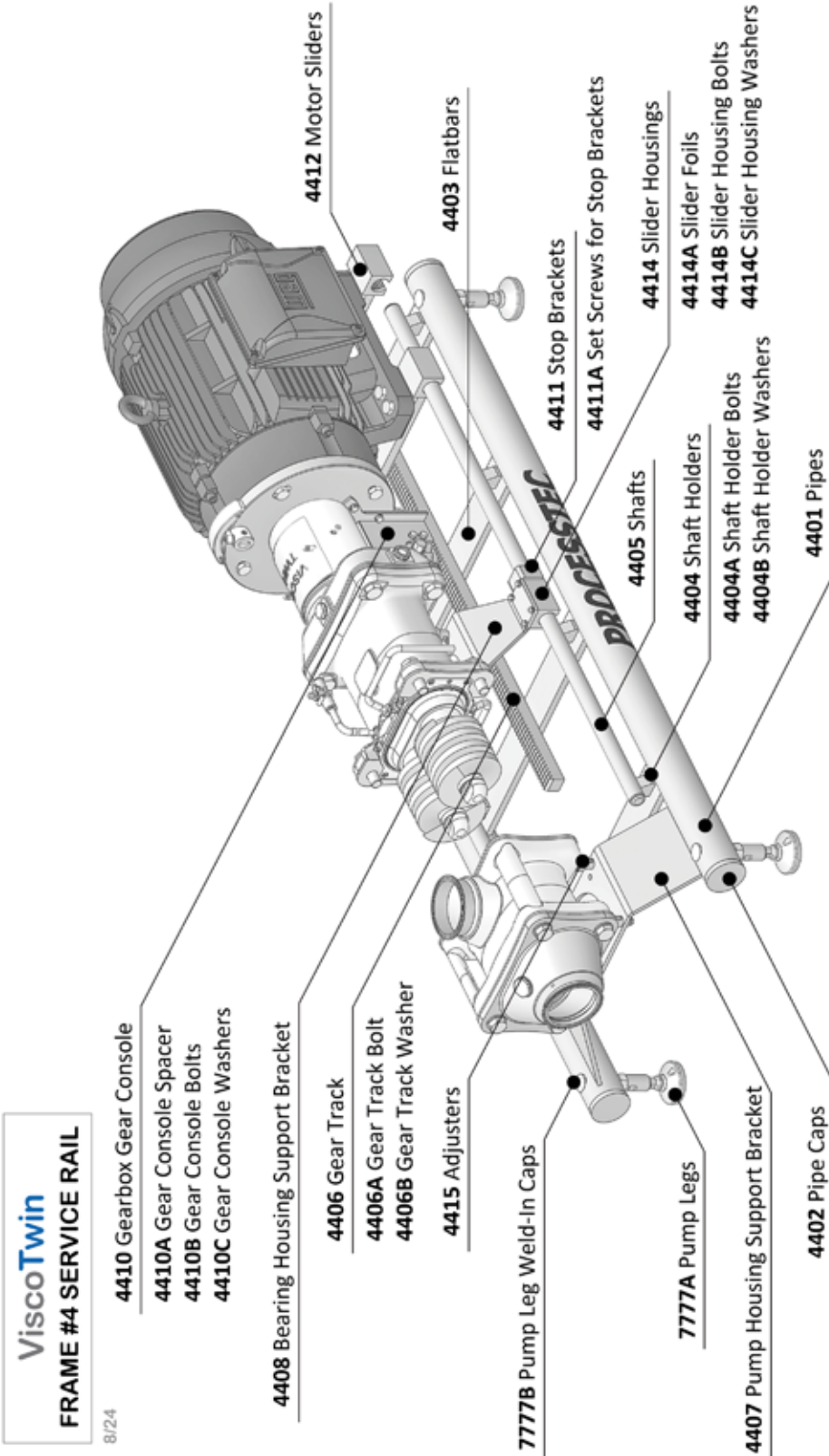

Tabloid Size
(11" x 17")